

CEGASA

Energy you can trust



E/Bick HV

Installation Manual

Original manual
June 2025

Control of revisions

VERSION	DATE	DESCRIPTION
June 2025	06.2025	Format update

Table of Contents

<u>1</u>	<u>Introduction</u>	<u>3</u>
<u>1.1</u>	<u>Purpose of the manual</u>	<u>3</u>
<u>1.2</u>	<u>Confidentiality.....</u>	<u>3</u>
<u>1.3</u>	<u>Safety during assembly</u>	<u>4</u>
<u>1.3.1</u>	<u>General.....</u>	<u>4</u>
<u>1.3.2</u>	<u>Mechanical.....</u>	<u>4</u>
<u>1.3.3</u>	<u>Fire prevention measures</u>	<u>5</u>
<u>1.3.4</u>	<u>Anti-electrolyte measures.....</u>	<u>5</u>
<u>2</u>	<u>Components</u>	<u>6</u>
<u>2.1</u>	<u>Base (109286)</u>	<u>6</u>
<u>2.2</u>	<u>HV EBICK Module (110025)</u>	<u>8</u>
<u>2.3</u>	<u>Connection cables (109663; 109664; 109687)</u>	<u>9</u>
<u>2.4</u>	<u>HV BMU control unit (110037)</u>	<u>10</u>
<u>2.5</u>	<u>Master MCS unit (110052).....</u>	<u>11</u>
<u>3</u>	<u>Necessary tools</u>	<u>12</u>
<u>4</u>	<u>Installation.....</u>	<u>13</u>
<u>5</u>	<u>Inverter connection</u>	<u>35</u>
<u>5.1</u>	<u>Connections of a single string.....</u>	<u>36</u>
<u>5.2</u>	<u>Multistring connection (2–8)</u>	<u>37</u>
<u>6</u>	<u>Configuration of the Master MCS unit.....</u>	<u>39</u>
<u>6.1</u>	<u>Modbus TCP/IP communication protocol</u>	<u>39</u>
<u>6.2</u>	<u>CAN Bus communication protocol</u>	<u>39</u>

1 INTRODUCTION

Read this manual carefully to ensure the energy storage Battery System is properly installed. All these operations must be performed by a qualified and authorised technician.

1.1 PURPOSE OF THE MANUAL

This is the complete manual for the installation of the energy storage system made up of the following products.

Table 1-1. Glossary.

TERM	DEFINITION
Module	HV EBick Module.
BMU	HV BMU control unit.
Master	Master MCS unit.
PDC	Distribution and protection cabinets.
Inverter	Hybrid inverter.
Tower	Group of Modules stacked high.
String	Group of Modules connected in series and controlled by an HV BMU control unit.
Battery System	Energy storage battery system.
EViewer web app	Battery System monitoring platform.
CEGASA Cloud	Cloud platform.

1.2 CONFIDENTIALITY

All the information provided by CEGASA ENERGIA SLU by virtue of this manual and any data or aspects that may become known as a result thereof will be absolutely confidential, and may not be provided to third parties or used for any purpose other than that intended, without the prior and express written authorisation of CEGASA ENERGIA SLU, (hereinafter CEGASA).

1.3 SAFETY DURING ASSEMBLY

The Battery System has been designed and tested in accordance with international safety standards. However, to avoid personal injury and property damage and ensure long-term operation of the Battery System, you must read this section carefully and follow all recommended safety measures.

1.3.1 General

- The area around the Battery System must be kept clear and free of combustible materials, petrol and/or other flammable vapours and liquids.
- Any air inlet or outlet in the room must be clear and free of obstacles.
- There must be no signs of deterioration in any component of the Battery System. Contact CEGASA with any questions.
- Do not access the interior of the BMU, or the Modules, or manipulate any internal components.
- Do not use or manipulate the Battery System components if your feet or hands are wet.
- Ensure that the output and input connection cables are not short circuited.
- Ensure that there is no short-circuit between positive and negative terminals at any point.
- Follow the specifications proposed by CEGASA for the power and communications cables of the installation.
- Do not use, handle, install or store the Battery System in locations with high humidity levels or subject to adverse weather conditions.

1.3.2 Mechanical

- The floor must be capable of holding the weight of the entire Battery System made up of one or multiple towers. The floor must be in optimal condition.
- Due to the weight of the Modules (>90 kg), they must be installed by several people.
- Do not stack more than 4 Modules per tower. Always stack them on top of their base fixed to the floor and levelled according to the instructions.
- Brace/fix the tower to the wall at a height according to the instructions.
- Always connect the Modules to each other (front/rear plates).

1.3.3 Fire prevention measures

- Ensure there is a carbon dioxide extinguisher nearby.
- Do not use water to extinguish the fire.
- Full protective clothing and self-contained breathing apparatus are required for firefighters to extinguish the fire.

1.3.4 Anti-electrolyte measures

If the Battery System loses electrolyte due to a malfunction thereof, avoid contact with the leaking liquid or gas.

Electrolyte is corrosive and contact can cause skin irritation and chemical burns. In case of exposure to this substance, proceed as follows:

- Inhalation: Evacuate the contaminated area.
- Contact with eyes: Rinse eyes with cold water for 15 minutes.
- Contact with skin: Carefully wash the affected area with cold water and soap.
- Ingestion: Induce vomiting.

In any of the above cases, seek immediate medical assistance.

2 COMPONENTS

2.1 BASE (109286)

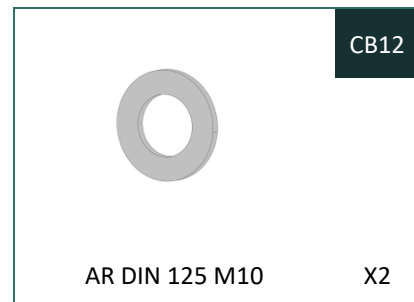
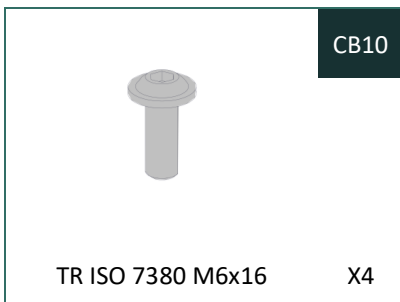
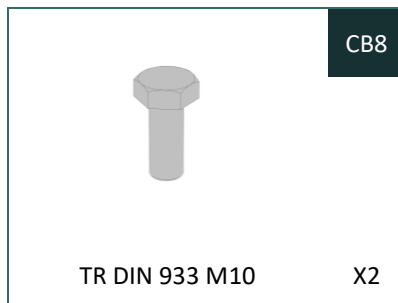
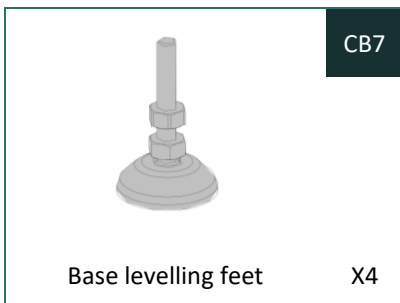
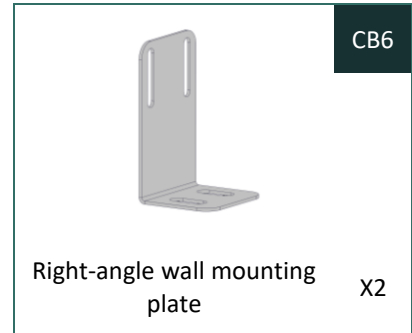
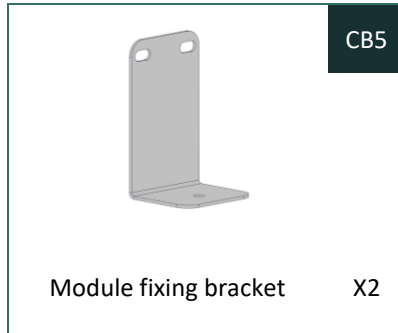
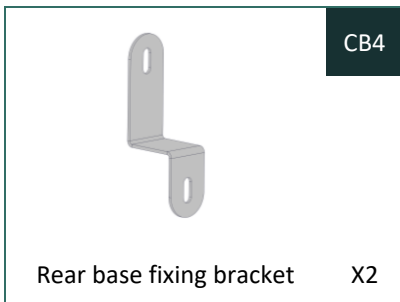
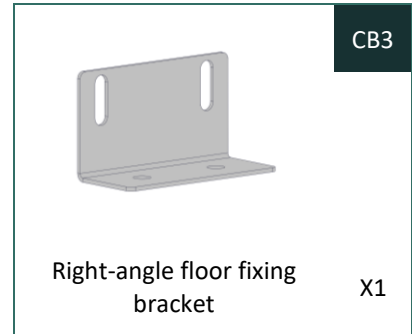
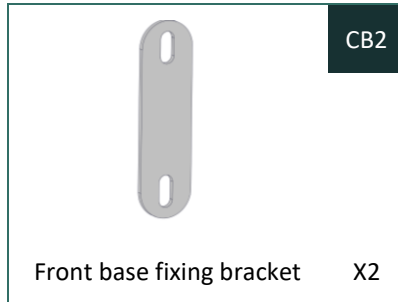
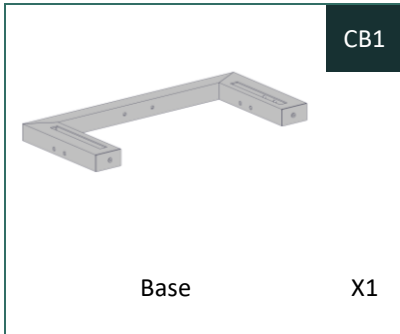

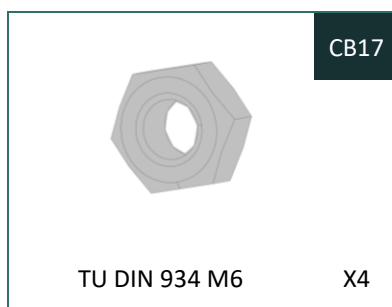
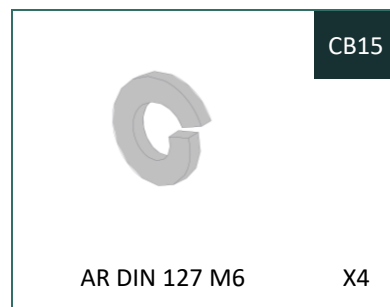
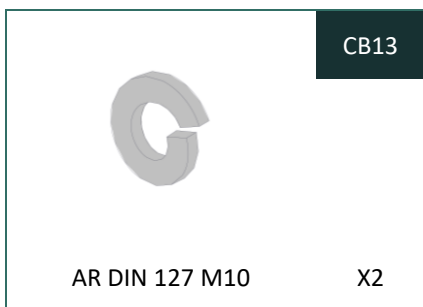

2.2 HV EBICK MODULE (110025)

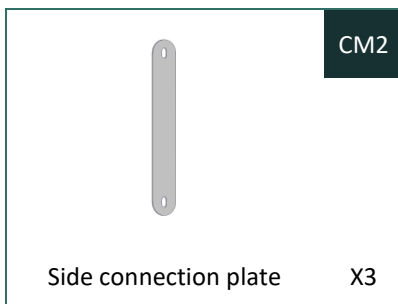
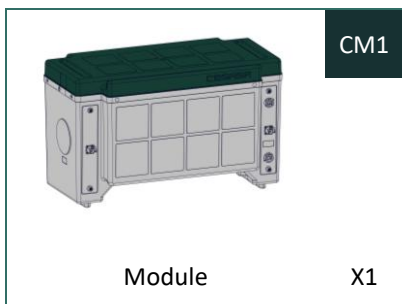

2.3 CONNECTION CABLES (109663; 109664; 109687)

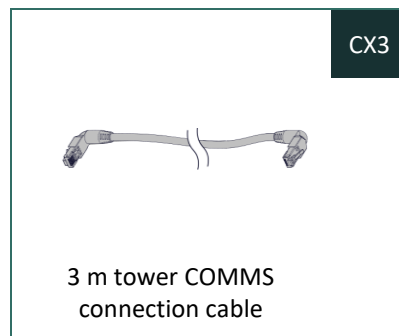
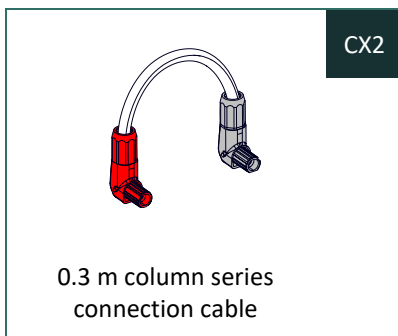
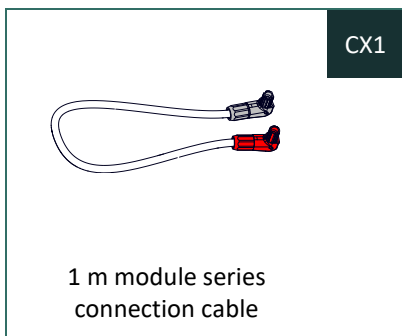

2.4 HV BMU CONTROL UNIT (110037)

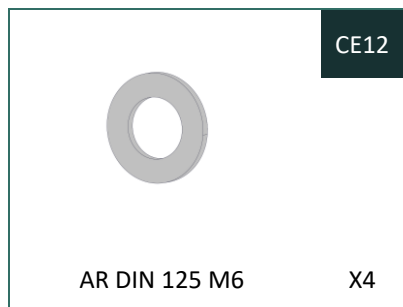
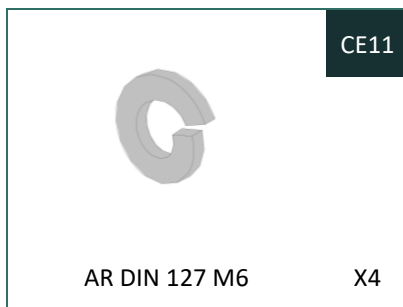
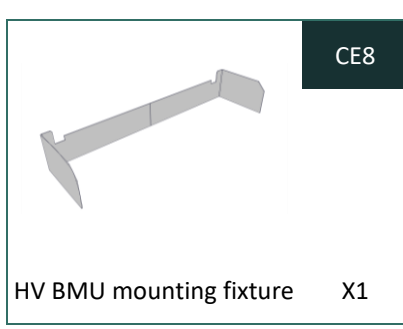
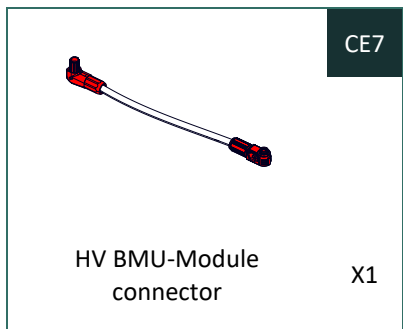
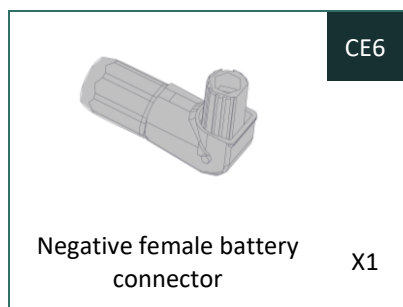
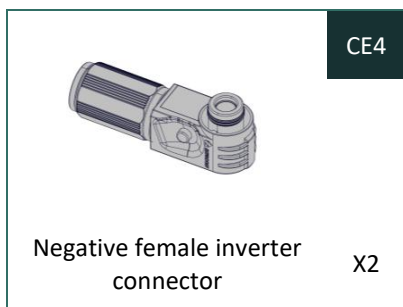
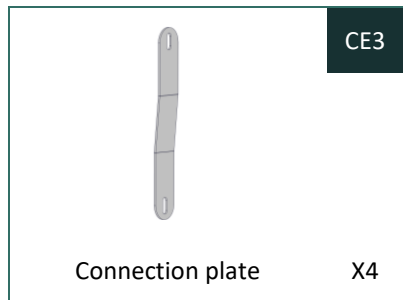
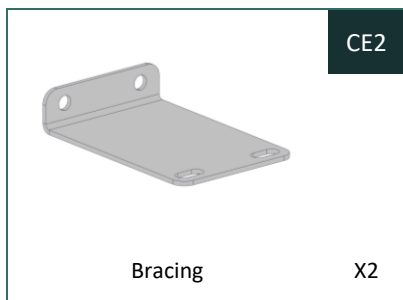
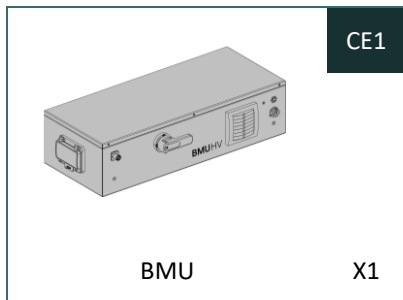

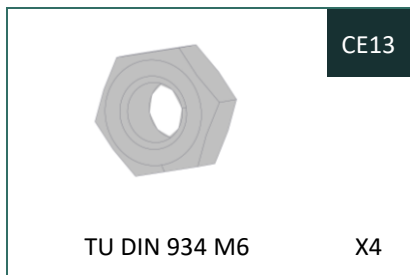

2.5 MASTER MCS UNIT (110052)

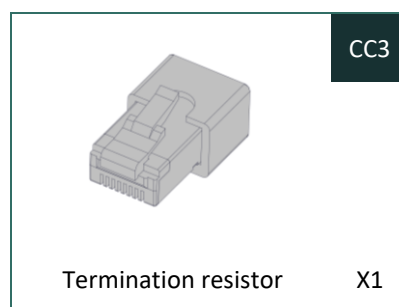
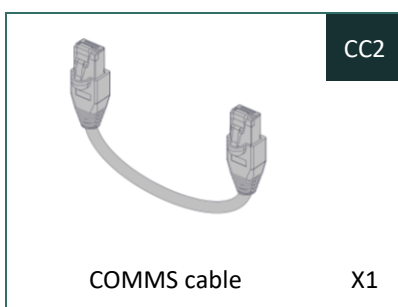
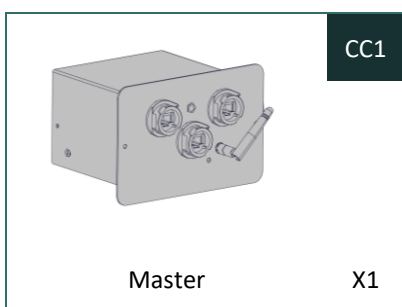

3 NECESSARY TOOLS

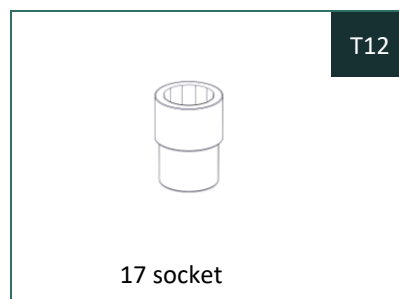
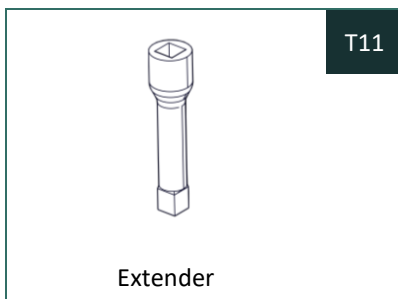
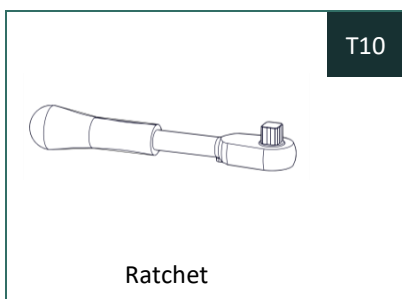
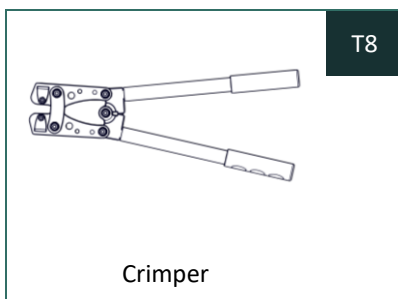
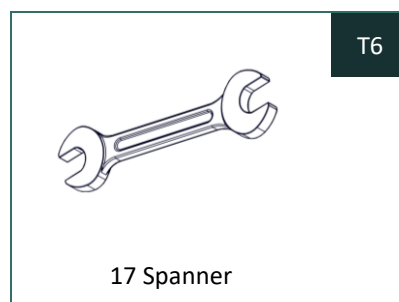
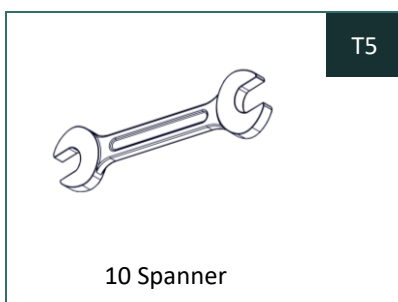
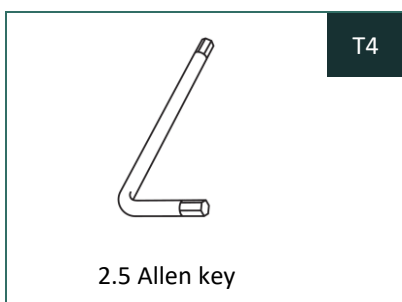
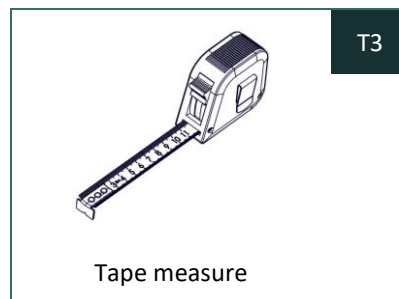

4 INSTALLATION



The following installation procedure is based on an HV EBick Battery System consisting of 15 modules. However, these steps can also be followed to install a Battery System containing between 3 and 20 modules.

15-Module Battery System	
Rated voltage	720 V
Voltage range	653–780 V
Power	202 kWh
Approximate dimensions	3205x405x2075 mm

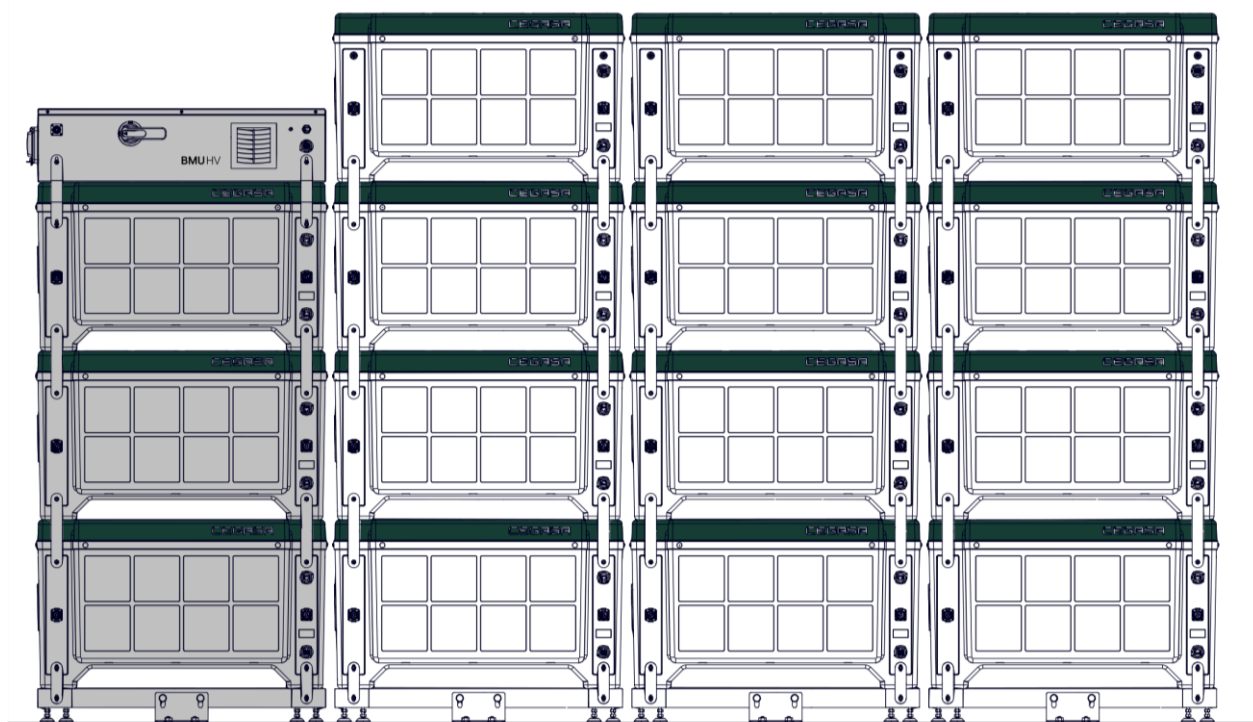

Follow steps 1 to 11 to assemble the tower with the BMU on top.

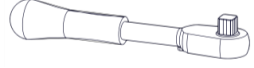

1	 Right-angle floor fixing bracket X1	CB3	 Drill	T1	 Ratchet	T10
----------	--------------------------------------------------------------------------------------------------------------------------	-----	--------------------------------------------------------------------------------------------	----	------------------------------------------------------------------------------------------------	-----

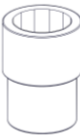
 17 socket	T12
------------------------------------------------------------------------------------------------	-----

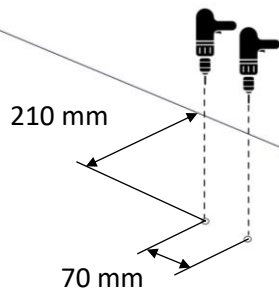

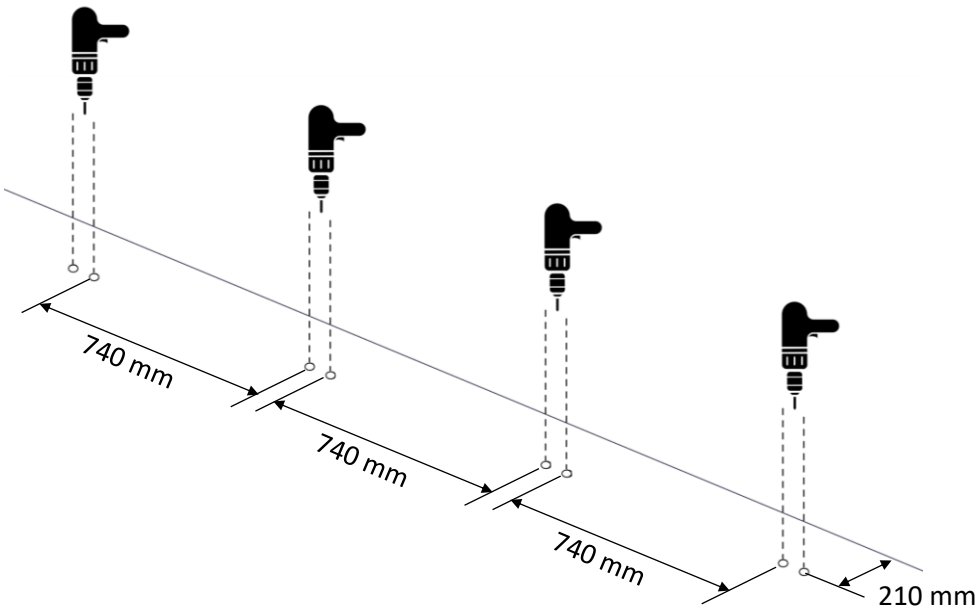

i Distance between the holes for 2-5, towers with a recommended distance of 50 mm between bases. (See pg. 27)

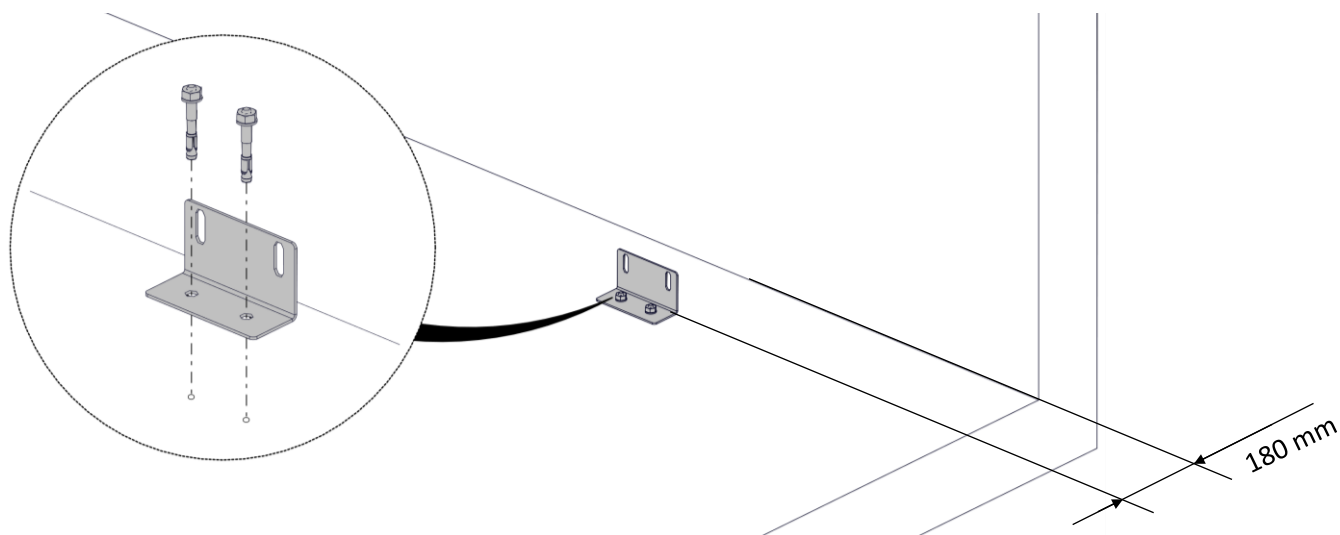

i Use of M10 metal expansion bolts is recommended. Not provided by CEGASA.

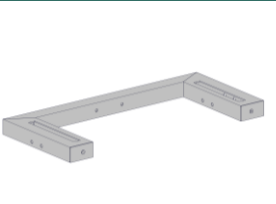
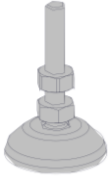

2	 Base X1	 Base levelling feet X4	 17 Spanner
	CB1	CB8	T6

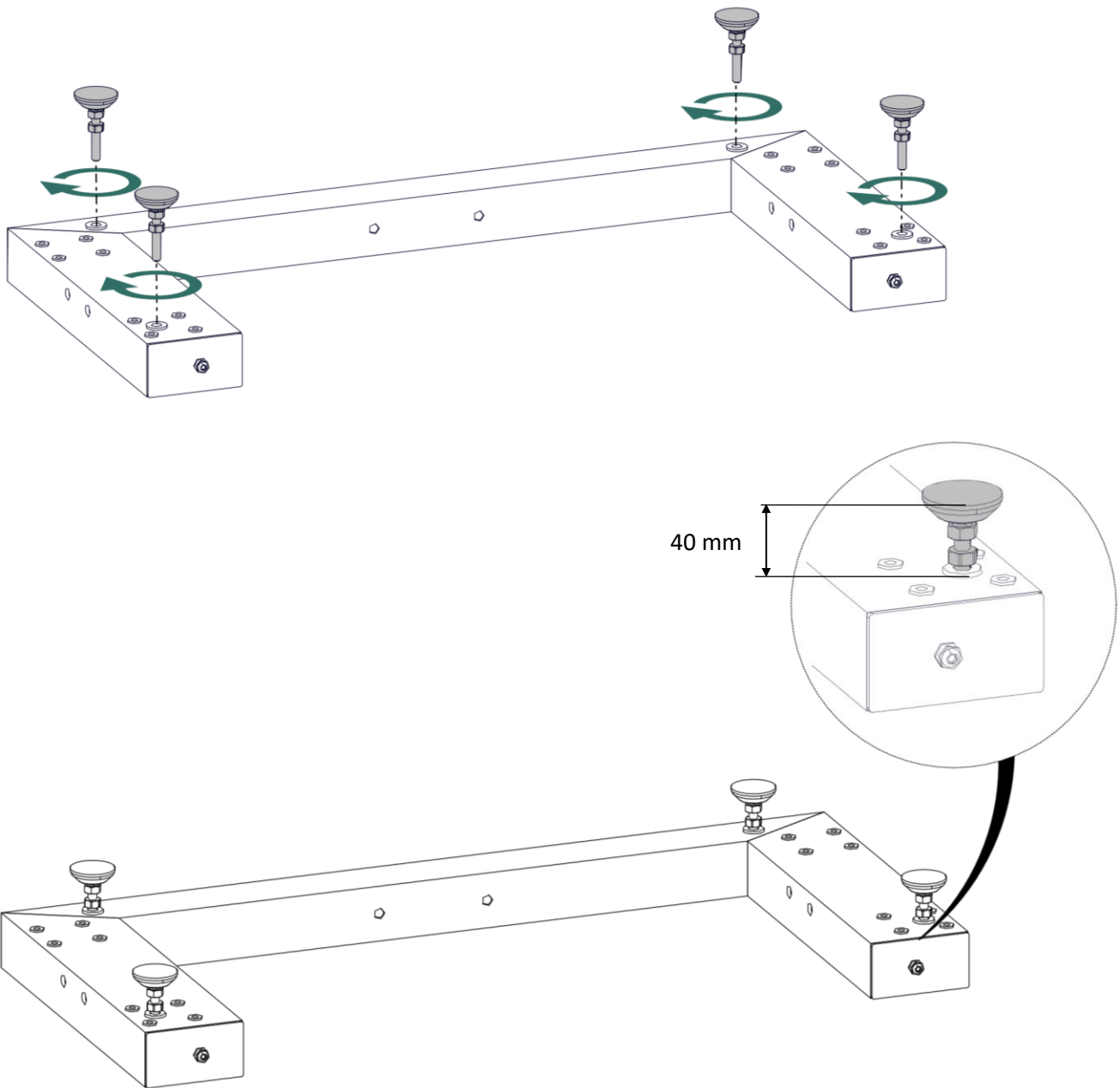

3



CB8

TR DIN 933 M10 X2



CB12

AR DIN 125 M10 X2



CB13

AR DIN 127 M10

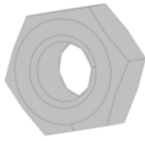

CB16

TU DIN 934 M10 X2

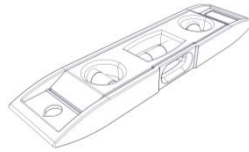

T2

Spirit level



T11

Extender

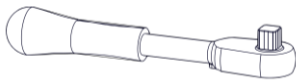

T10

Ratchet



T12

17 socket

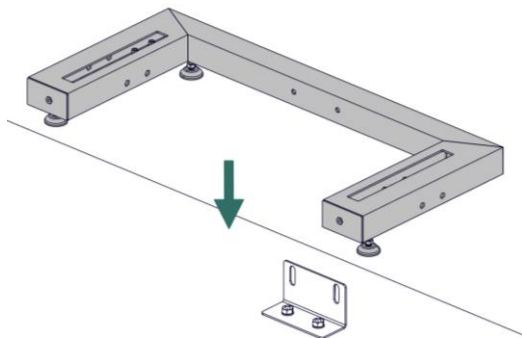

Check the levelling and adjust the feet if necessary.

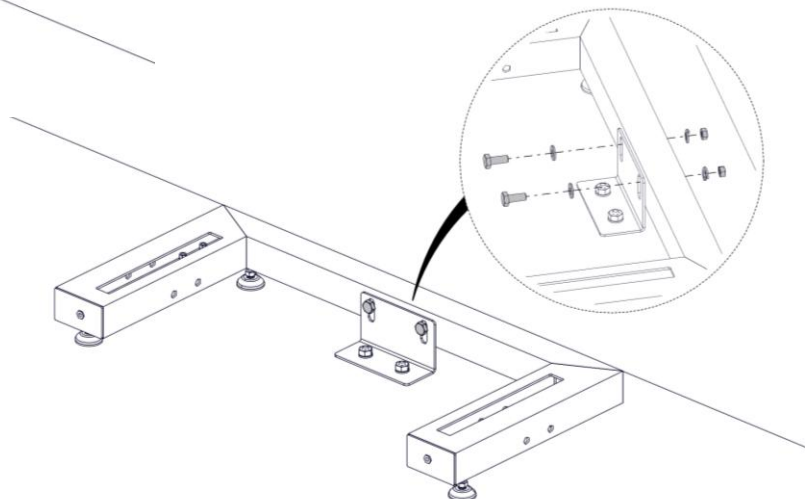

4

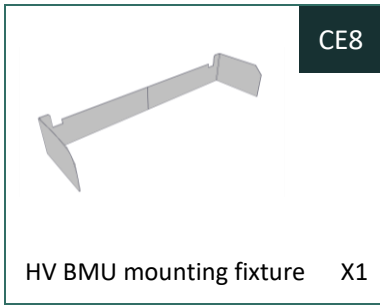

1

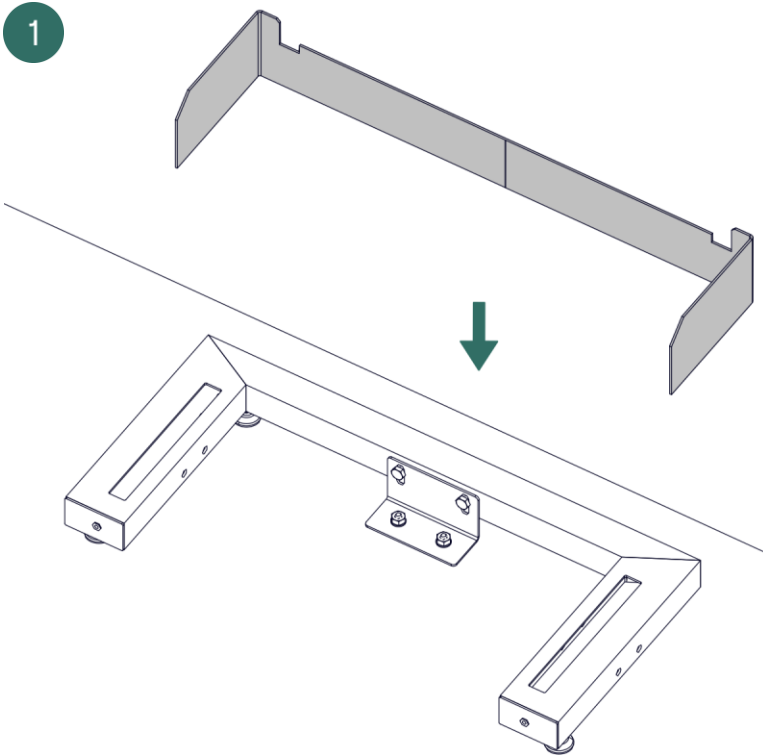

i Place the fixture against the wall.

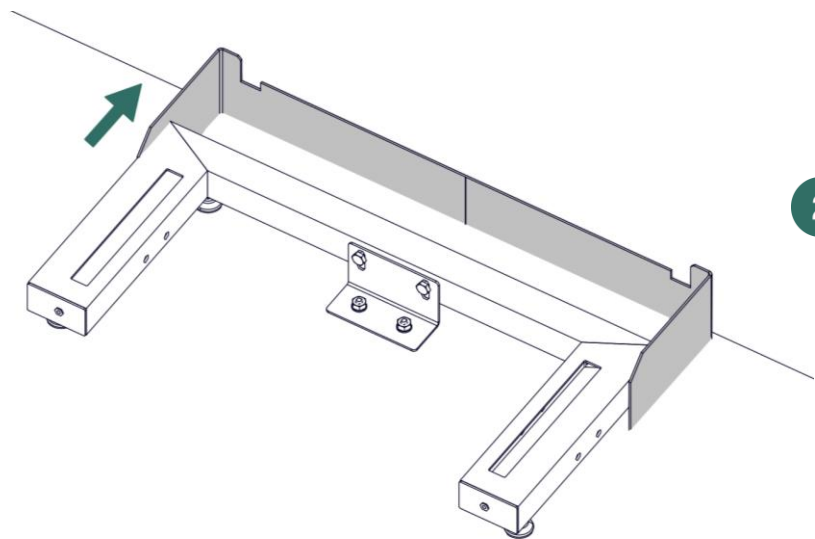

3

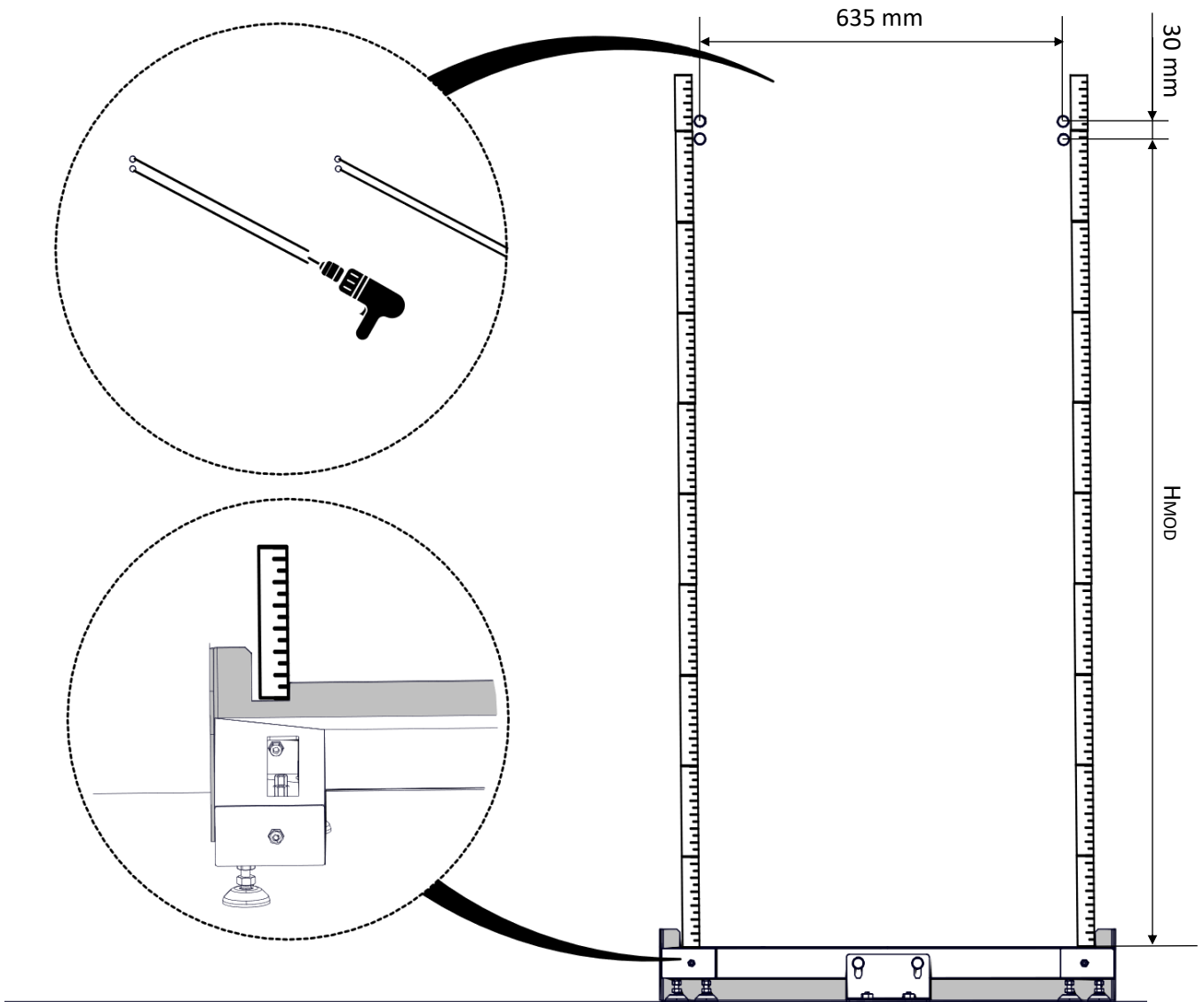

Ensure that the tape measure is positioned parallel to the fixture, flush against it, as shown in the image.

No. MODULES	HMOD
3	1380 mm
4	1826 mm

5



CM1

Module

X1



CB2

Front base fixing bracket

X2



CB4

Rear base fixing bracket

X2



CB9

TR ISO 7380 M6x20

X4



CB11

TR ISO 7380 M6x12

X4





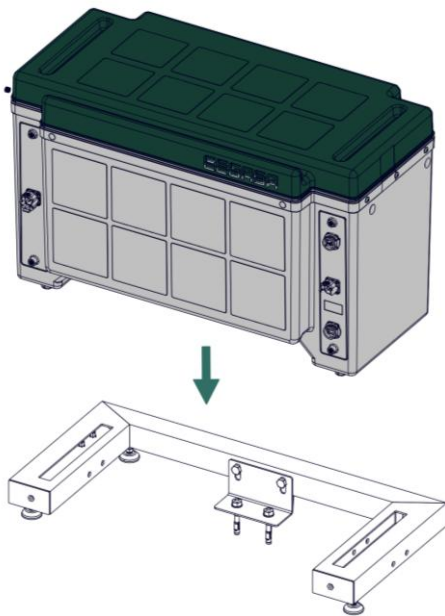

T7

Torx T30 screwdriver

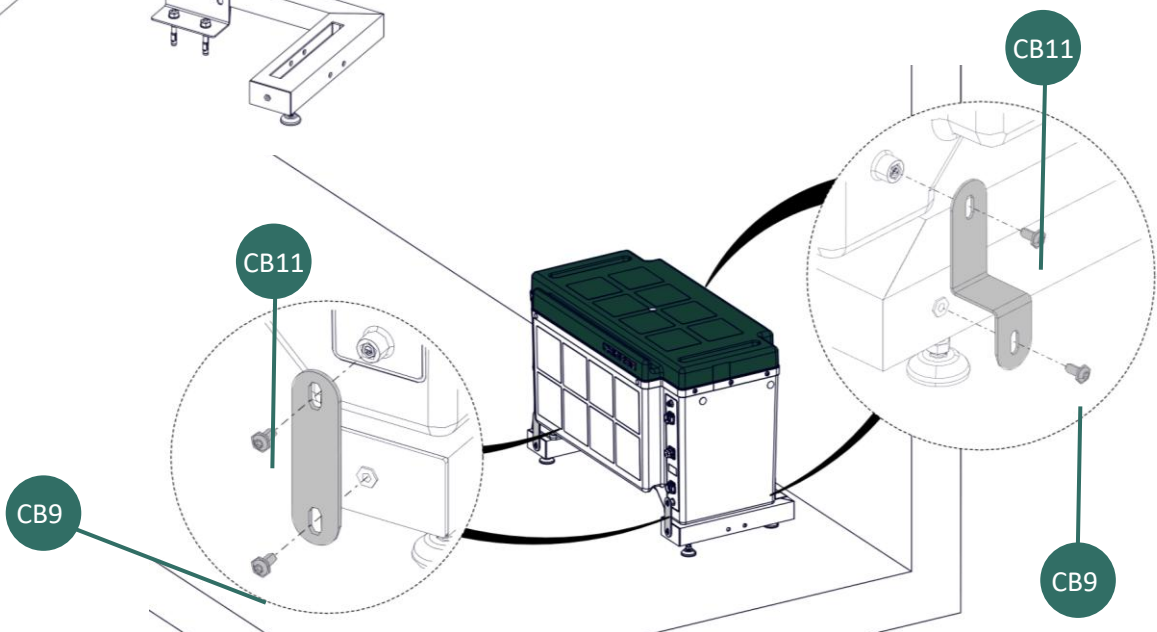

Step 5 to be performed by several people.



6		CM1
	Module	N
		CM2
	Side connection plate	4XN
		CM4
	TR ISO 7380 M6x12	8XN

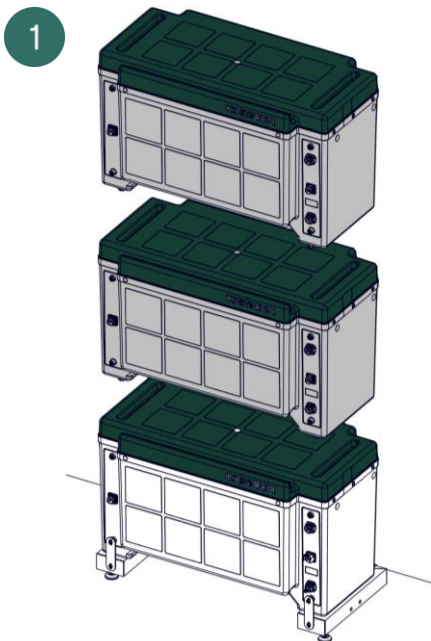

Place the desired number of modules from 1 to 4.

The installation is the same as in the lower module.

	T7
Torx T30 screwdriver	



Step 6.1 to be performed by several people.

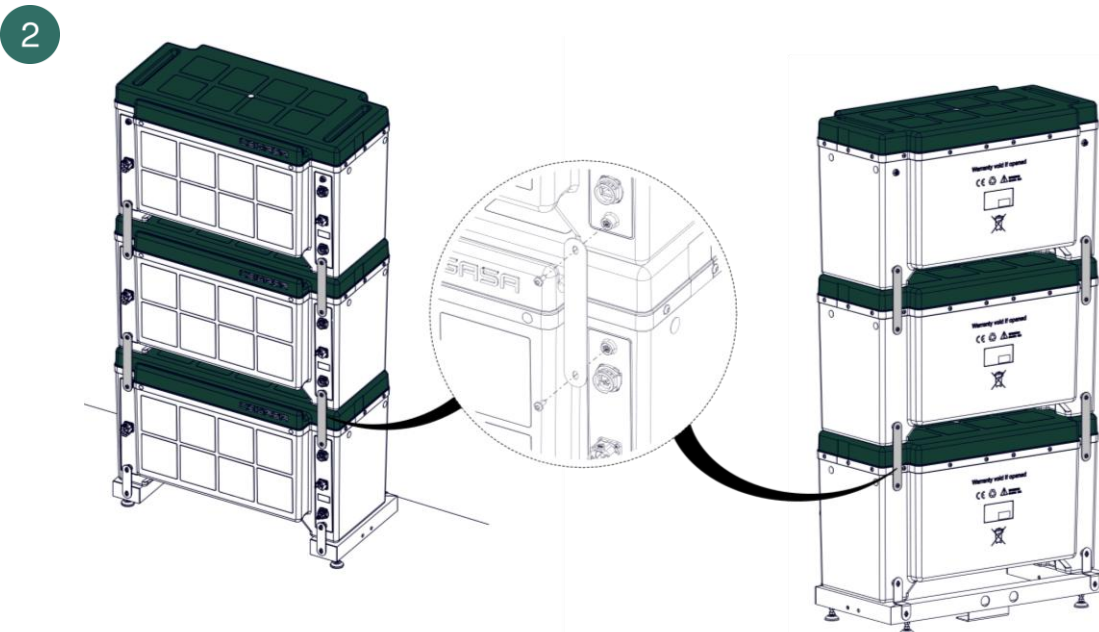

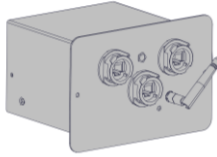
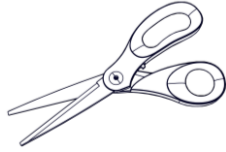
7	 BMU X1	 Master X1	 Scissors
	CE1	CC1	T9



Configure the Master before placing it in the HV BMU. See Chapter 6.

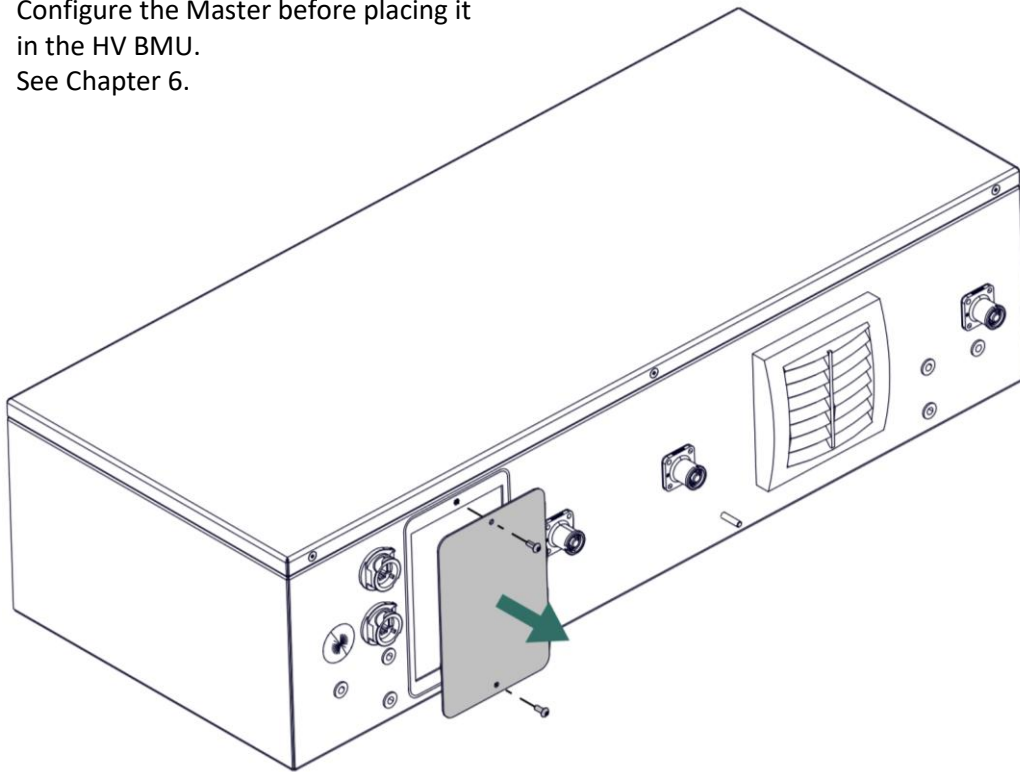

Be sure not to damage the cable when cutting the tie with scissors.

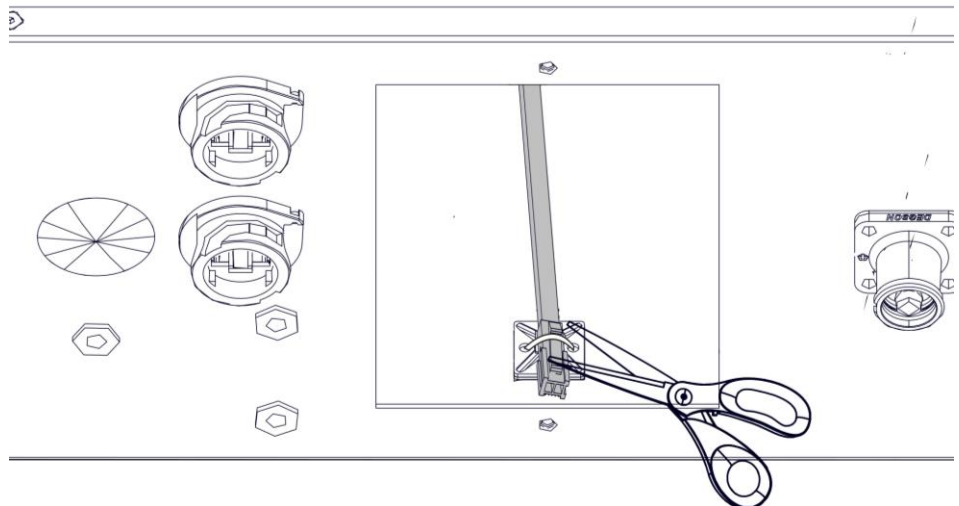

2

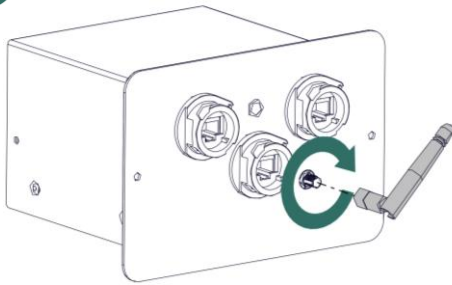

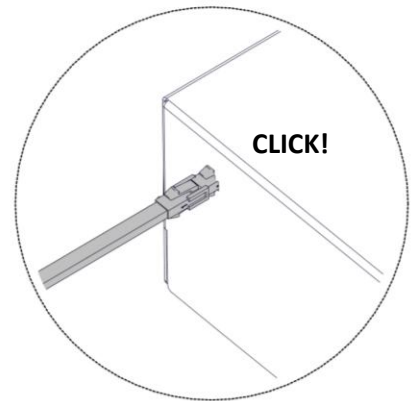
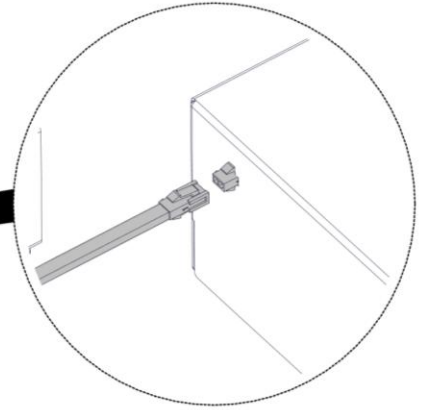
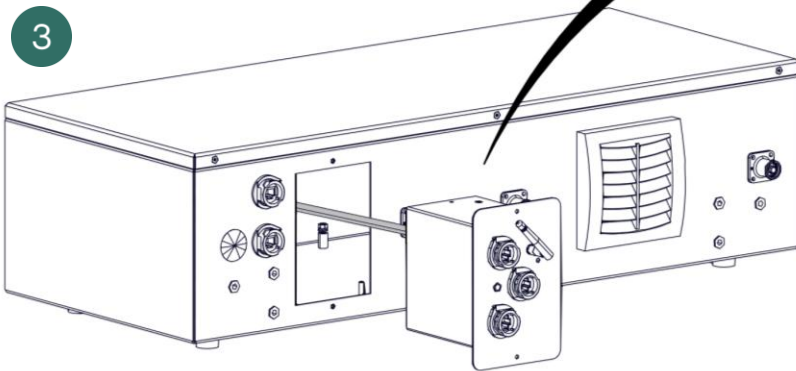

3



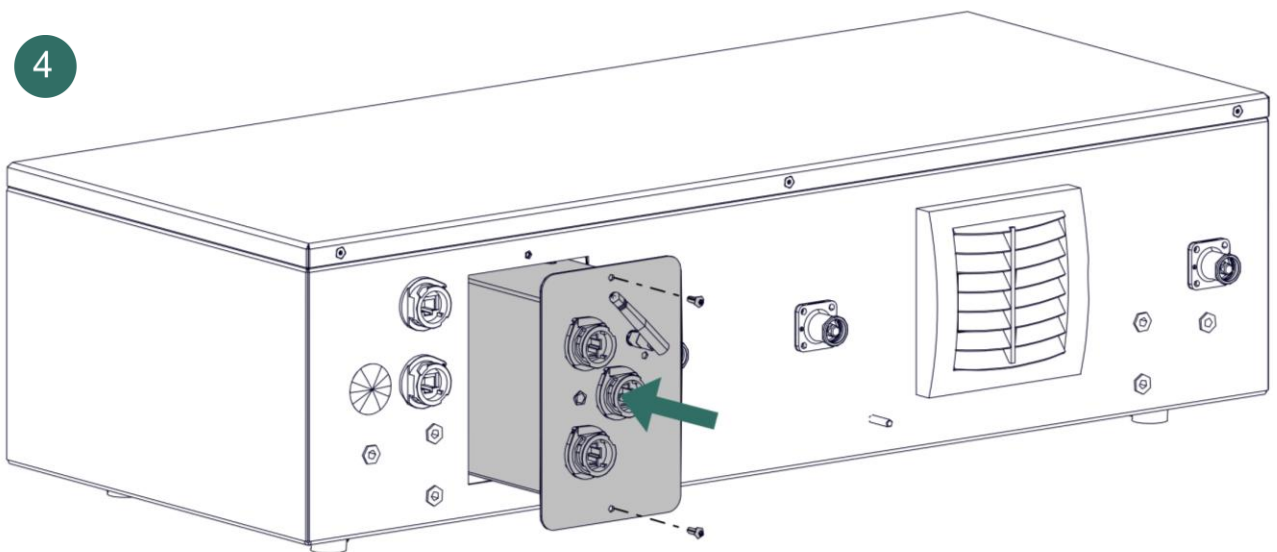

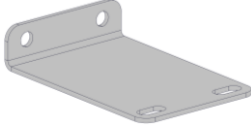
4

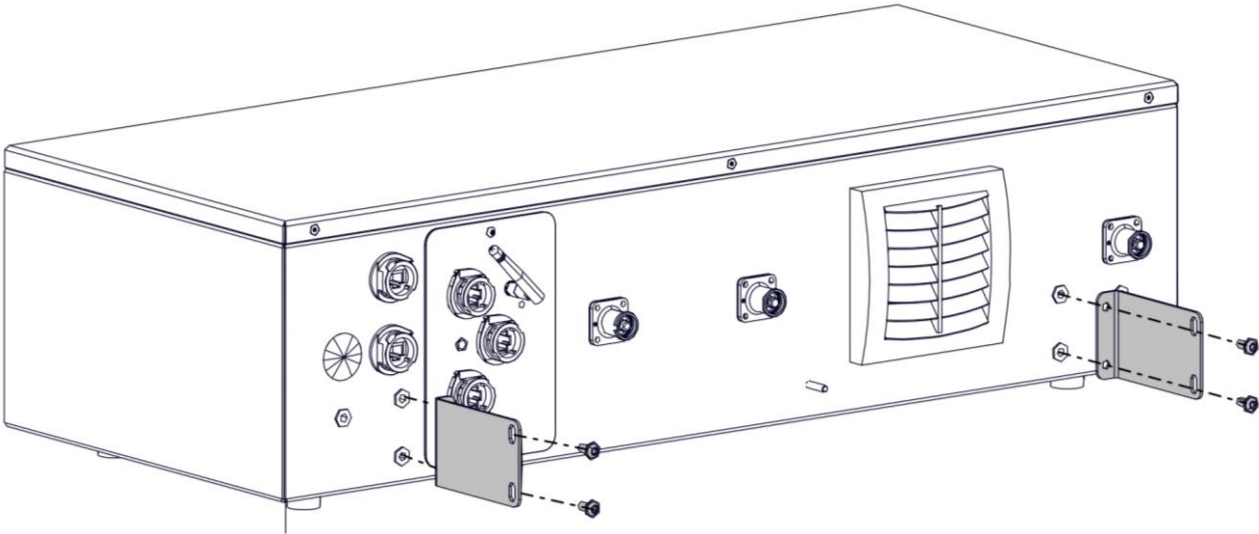

8	 Bracing X	 TR ISO 7380 M6x12 X4	 Torx T30 screwdriver
	CE2	CE10	T7

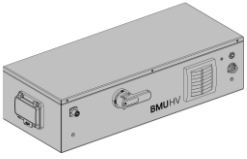

9	 BMU X1	 Connection plate X4	 TR ISO 7380 M6x12 X8

1	 Torx T30 screwdriver
----------	-------------------------------------------------------------------------------------------------------------

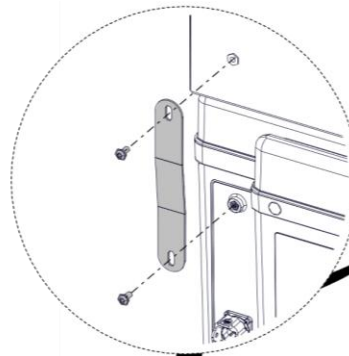
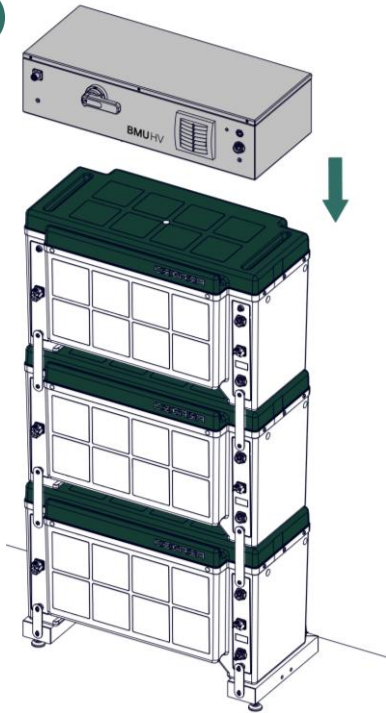

2

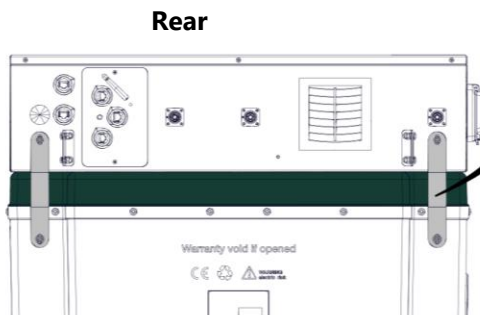
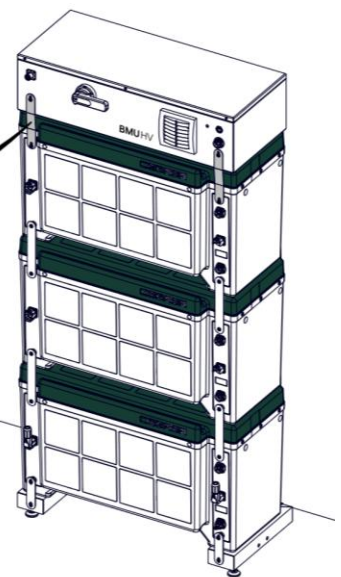

10

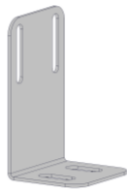

CB6

Right-angle wall mounting plate

X2



CE9

TR ISO 7380 M6X16

X4



CE11

AR DIN 127 M6

X4



CE12

AR DIN 125 M6

X4

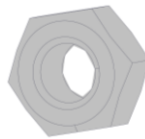

CE13

TU DIN 934 M6

X4

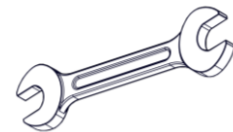

T5

10 Spanner



T7

Torx T30 screwdriver

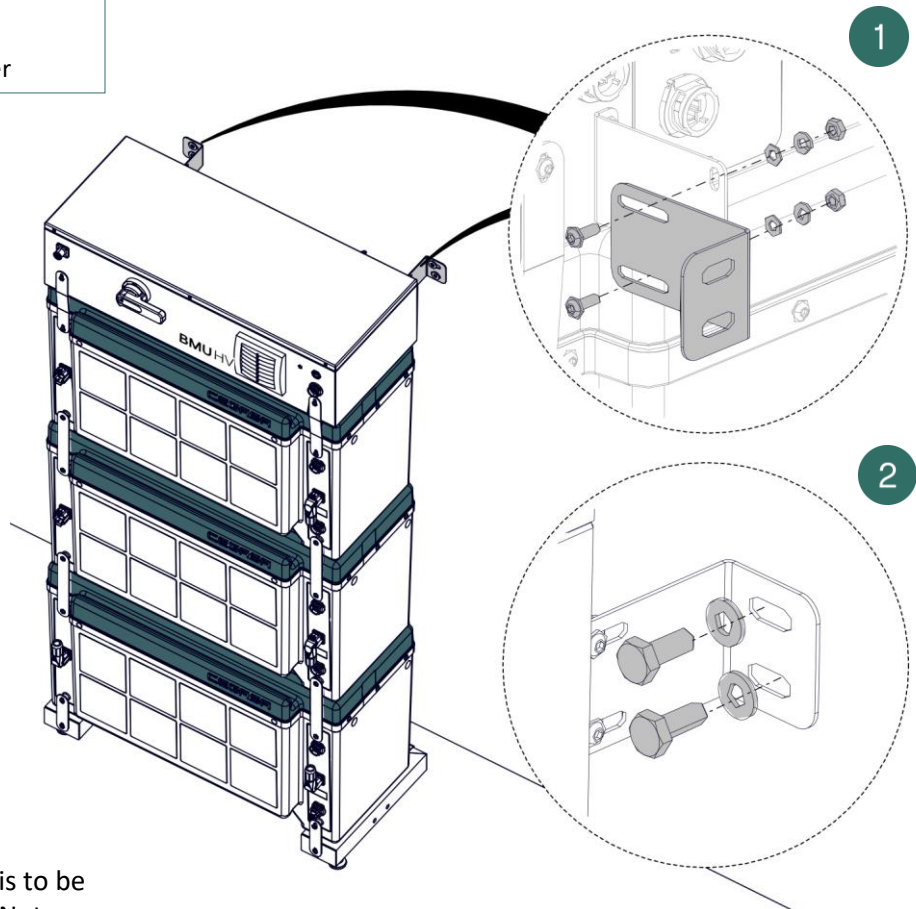







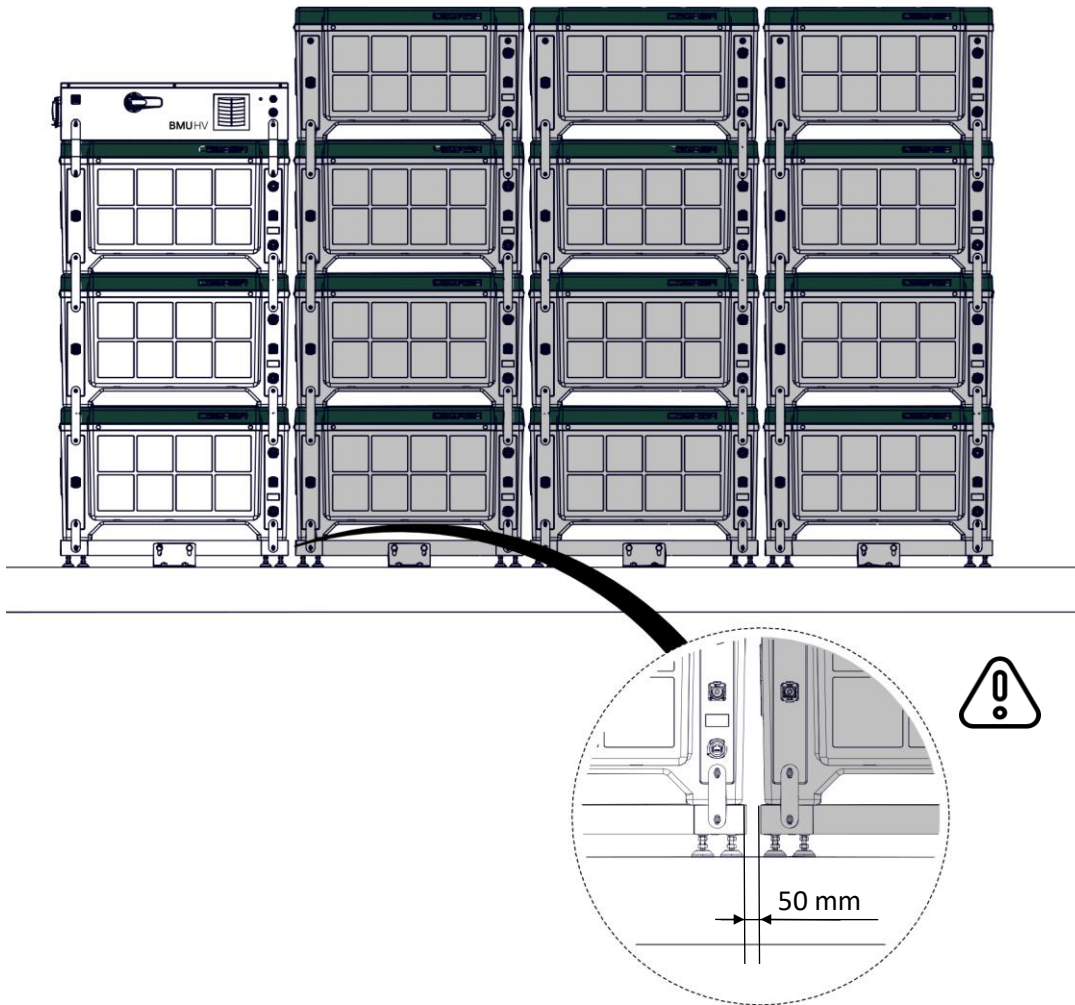

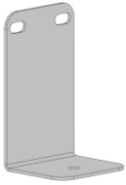

Use of M6x50 lag screws recommended. The plug is to be selected by the installer. Not provided by CEGASA.

11

i Follow steps 1, 2, 3, 5, 6, and 12 to assemble the towers without the HV BMU.



12		CB5
	Module fixing bracket	X2
		CB6
	Right-angle wall mounting plate	X2
	CB10	
TR ISO 7380 M6x16	X4	
	CB11	
TR ISO 7380 M6x12	X2	
	CB14	
AR DIN 125 M6	X4	
	CB15	
AR DIN 127 M6	X4	
	CB17	
TU 934 M6	X4	
	T1	
Drill	X4	
	T5	
10 Spanner		
	T7	
Torx T30 screwdriver		

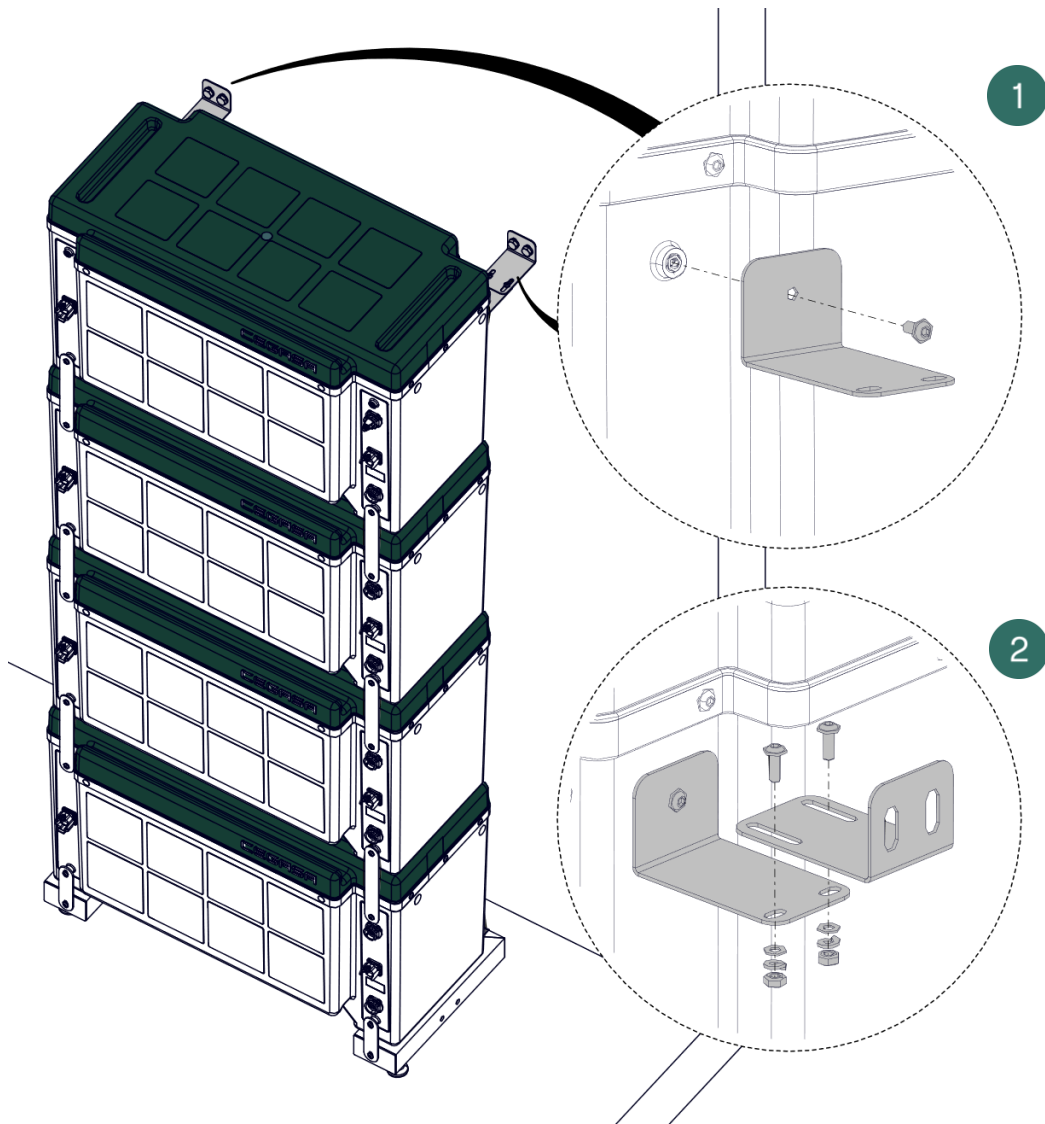

i Use of M6x50 lag screws recommended. The plug is to be selected by the installer. Not provided by CEGASA.

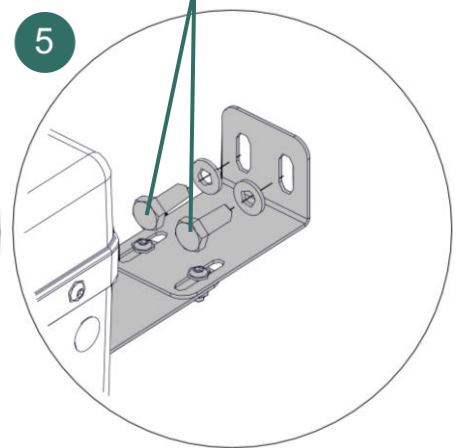
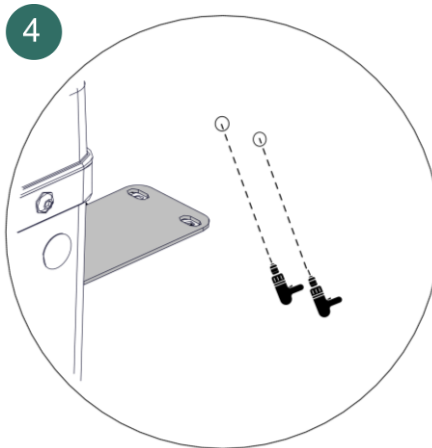
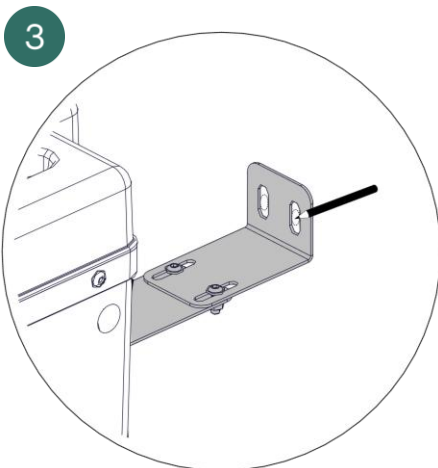

13

CM3



External CB RJ45

X12

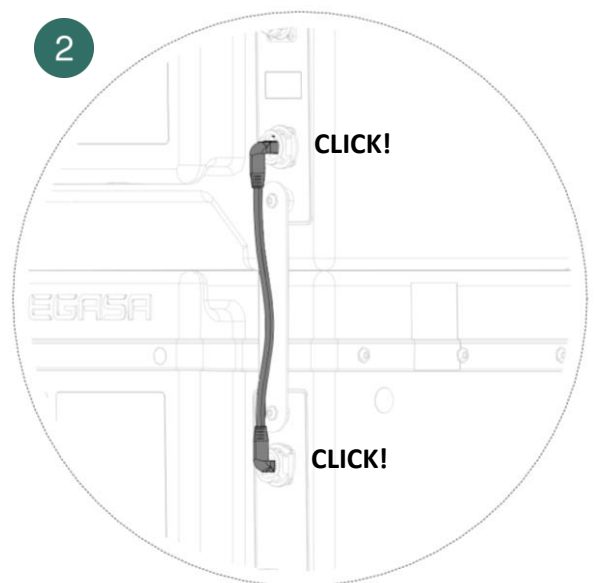
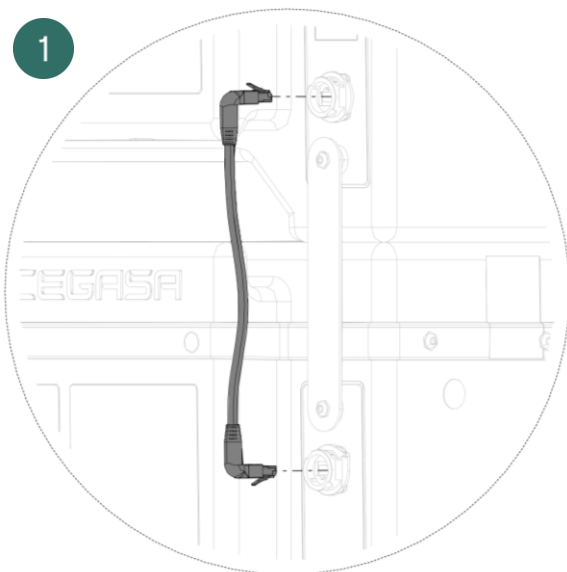
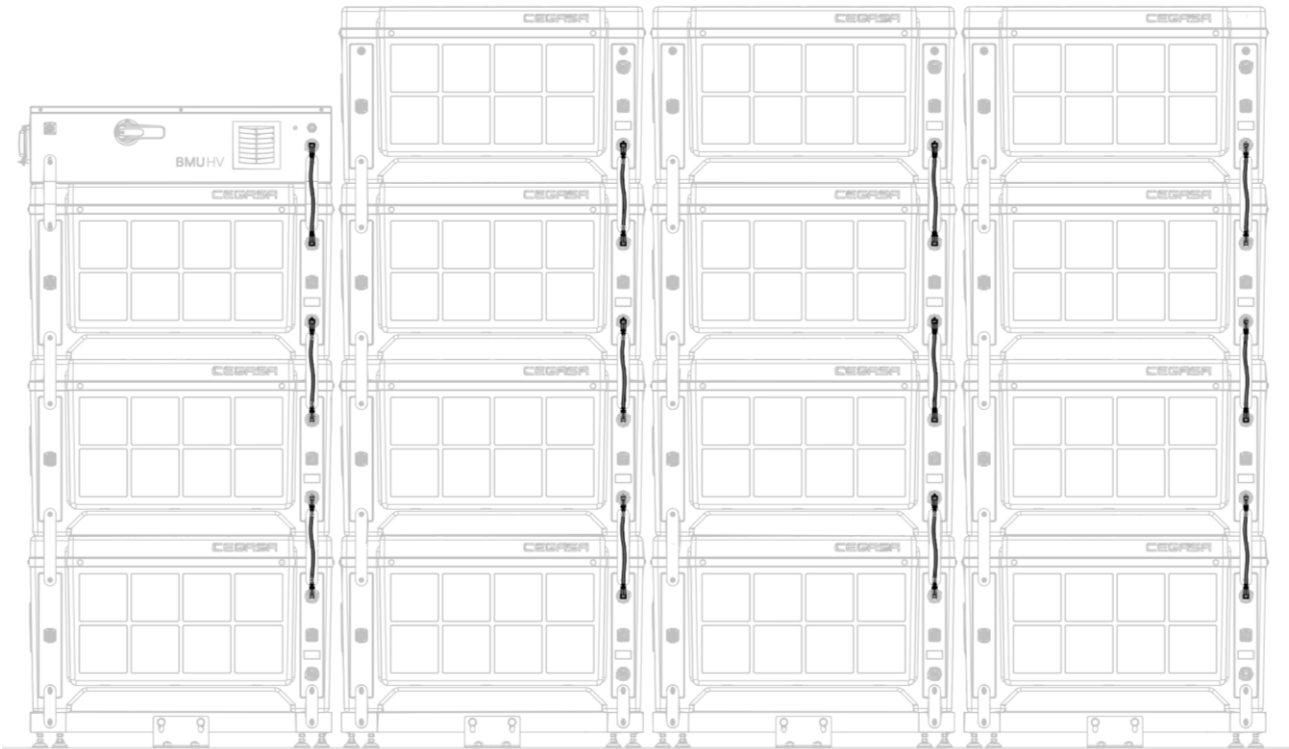



14

CX3

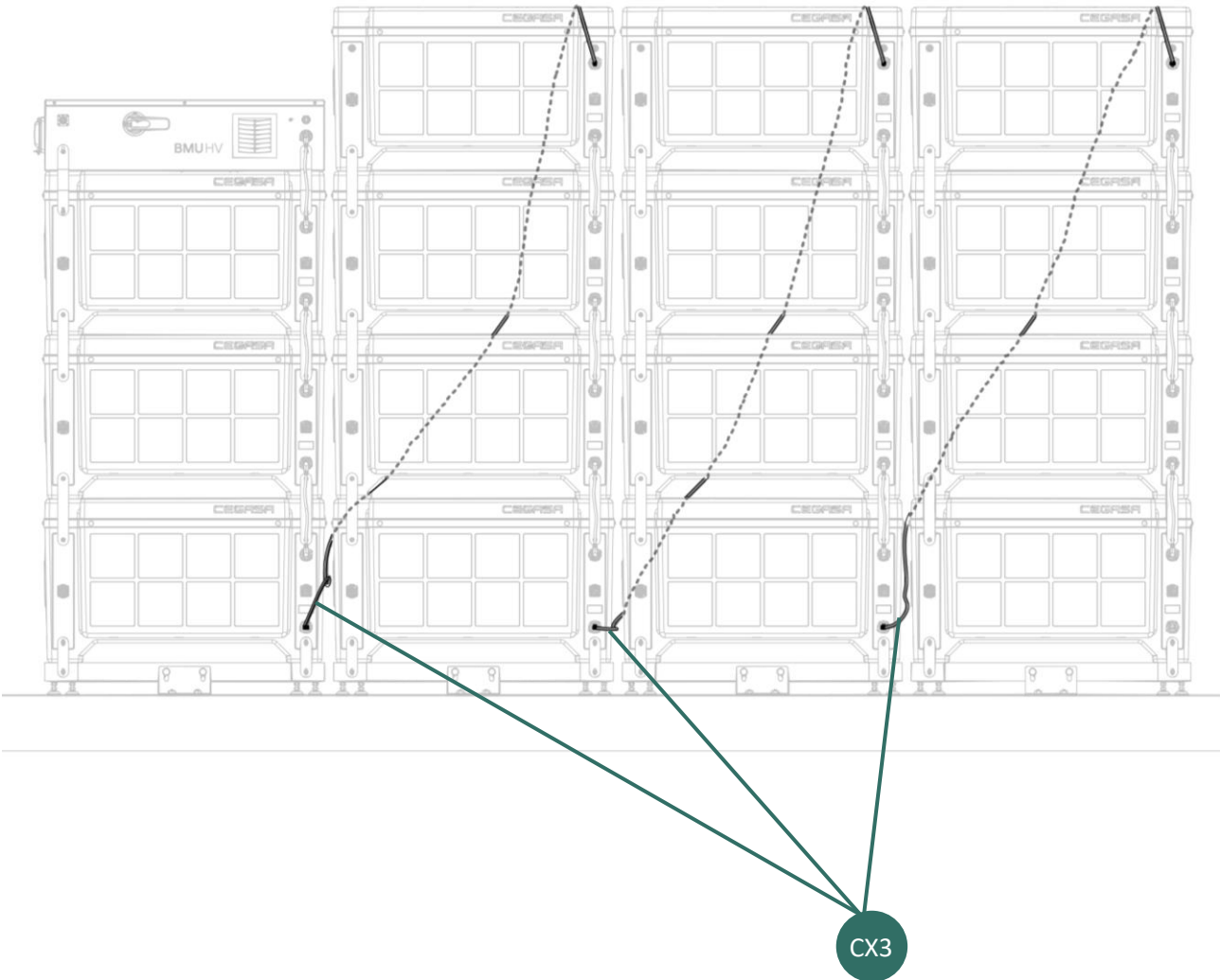

Tower COMMS connect. cable
X3

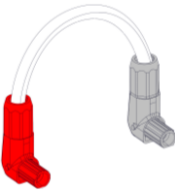

15	 0.3 m column series connection cable X3	CX1
	 1 m module series connection cable X11	CX2
	 HV BMU-Module connector X1	CE7

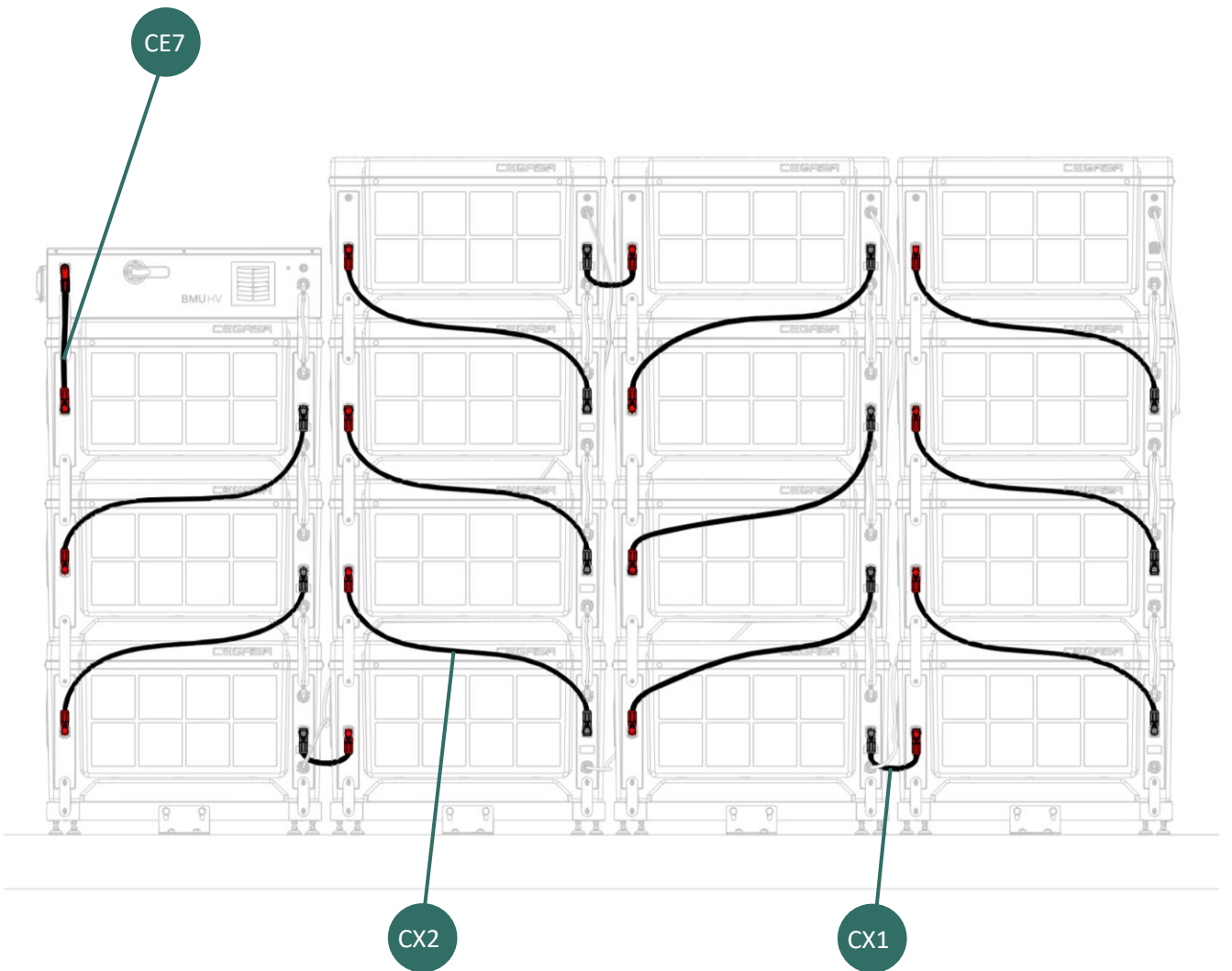

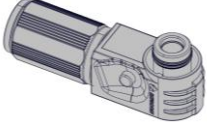
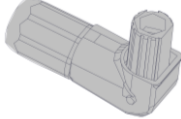
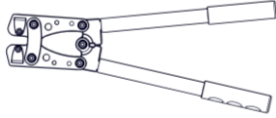
16	CE4		X1
	Negative female inverter connector		
	CE6		X1
Negative female battery connector			
			T8
Crimper			

i 1000 Vdc 50 mm² series power cable (-) between BMU and modules, not provided by CEGASA.

1 CE4 crimping



21 mm (±1)

Crimp the positive aerial connector 21 mm (±1).

2

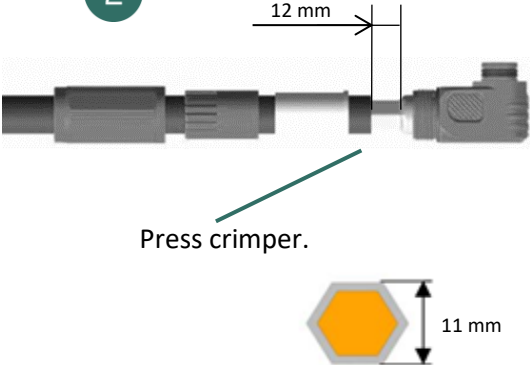

12 mm

11 mm

Press crimper.

3



Check that the cable is well crimped. If in doubt, contact CEGASA.

1 CE6 crimping



22 mm (±1)

Crimp the positive aerial connector 22 mm (±1).

2



Press crimper.

3



Check that the cable is well crimped. If in doubt, contact CEGASA.

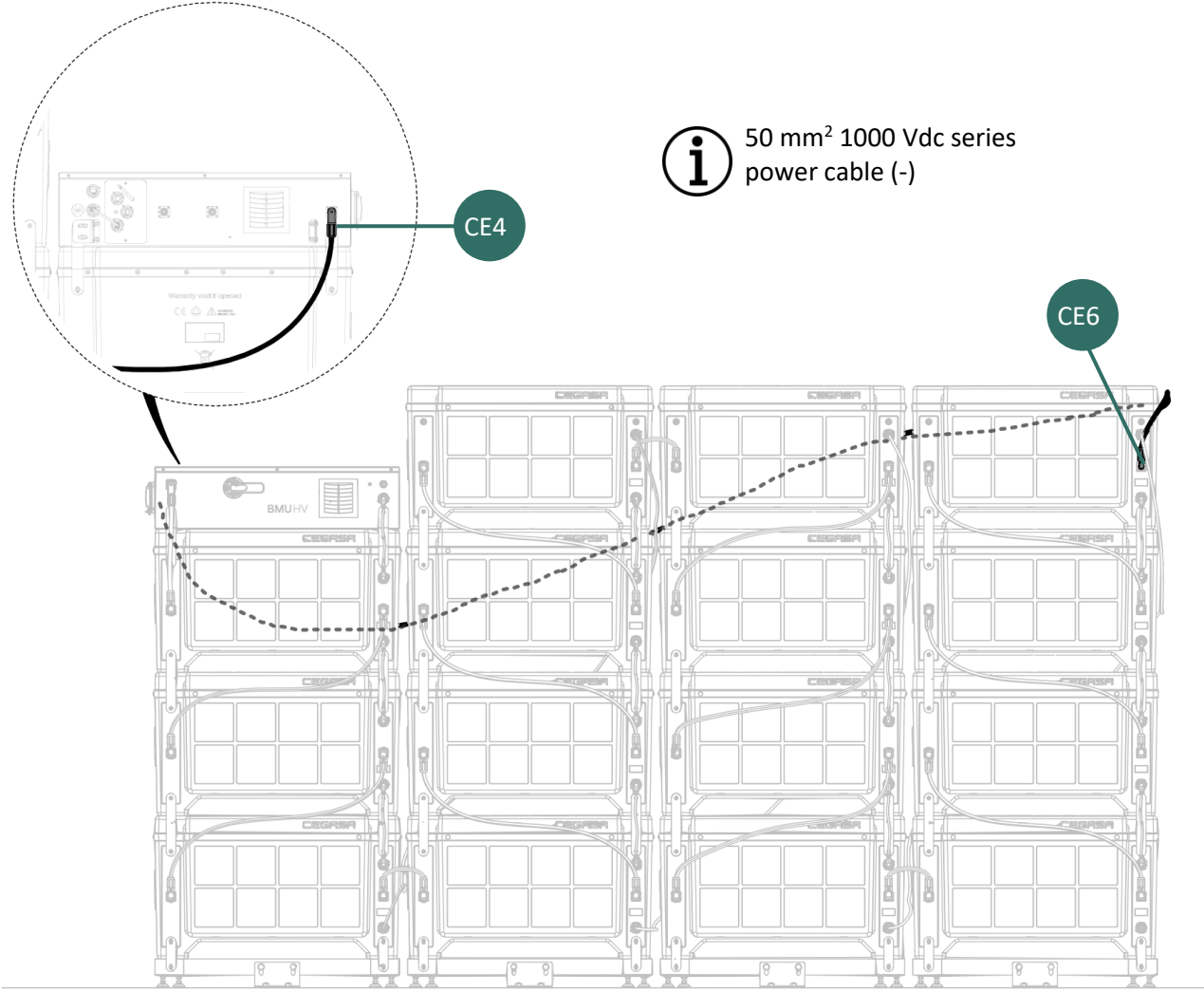

5 INVERTER CONNECTION

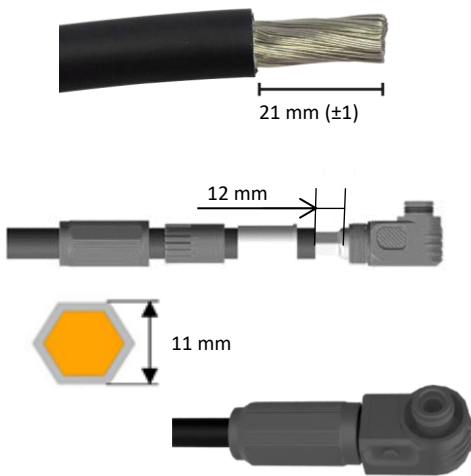
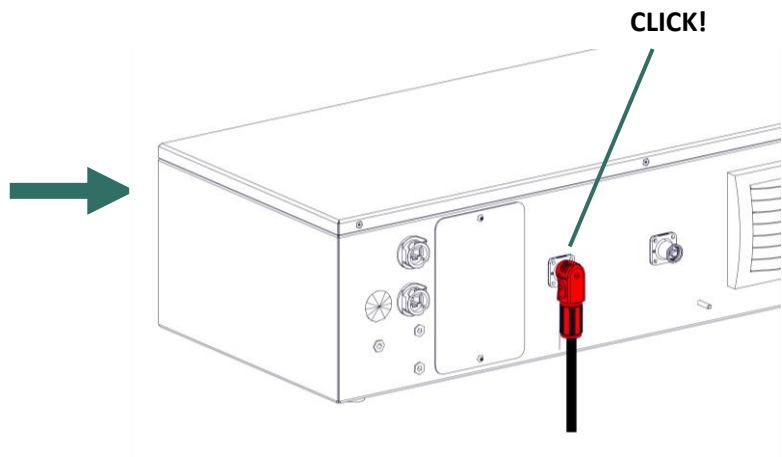
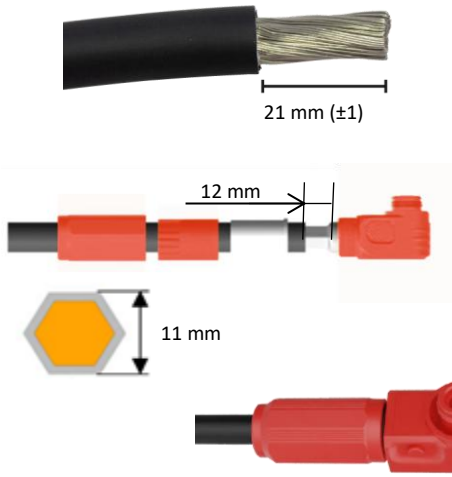
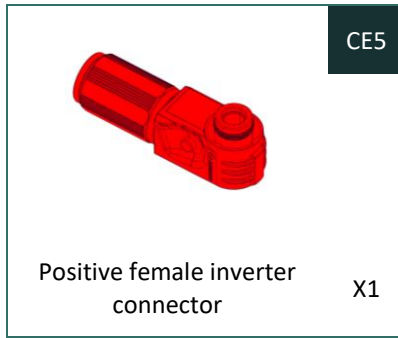
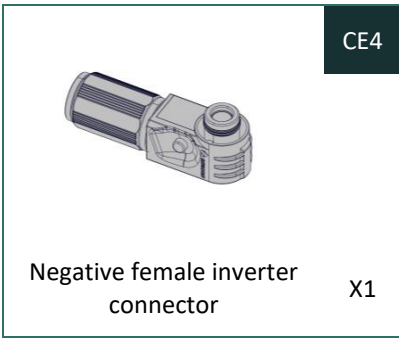

5.1 CONNECTIONS OF A SINGLE STRING

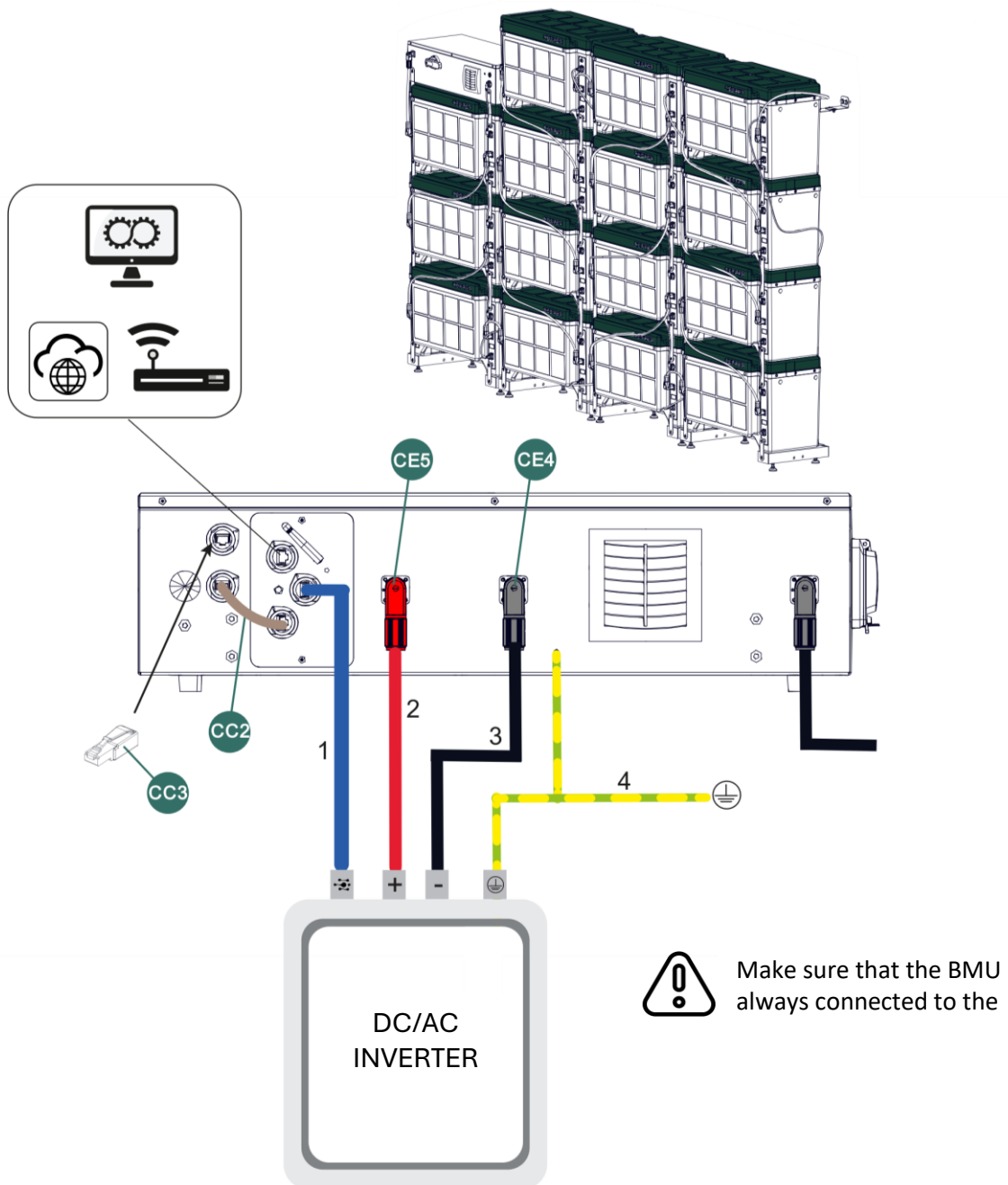

ITEM	TYPE OF CABLE	FEATURES
1	Inverter COMMS cable	Check pinout and characteristics of the network cable in the project inverter manual (not included).
2	Inverter positive cable	1000 Vdc cable with 50 mm ² section (not included).
3	Inverter negative cable	1000 Vdc cable with 50 mm ² section (not included).
4	Earthing cable	Earth cable with 10 mm ² section (not included).

5.2 MULTISTRING CONNECTION (2-8)



Make sure that the BMU is always connected to the earth.

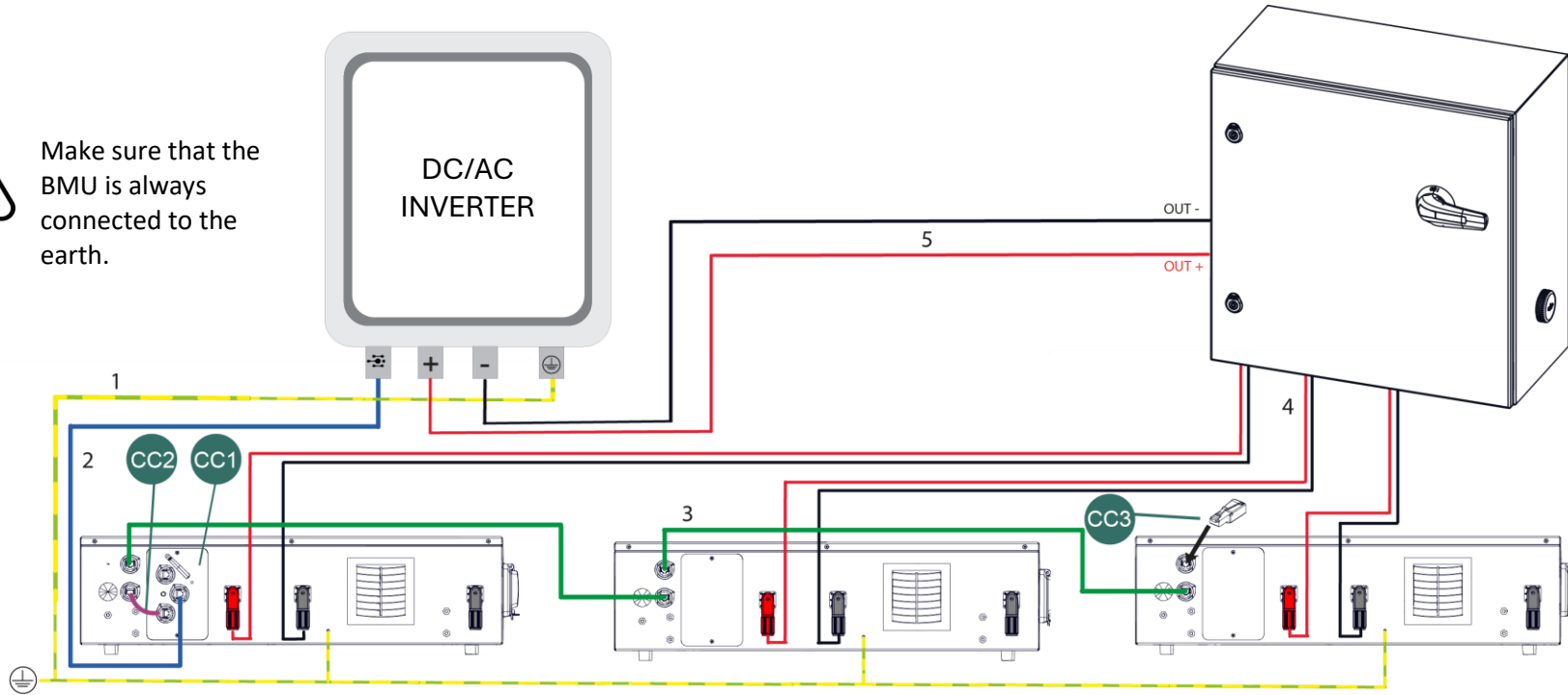

ITEM	TYPE OF CABLE	FEATURES
1	Earthing cable	Earth cable with 10 mm ² section (not included).
2	COMMS cable to the inverter	Check pinout and characteristics of the network cable in the project inverter manual (not included).
3	COMMS cable between HV BMU	Cat5e parallel UTP network cable (not included).
4	HV BMU output power cables	1000 Vdc cable with 50 mm ² section (not included).
5	Power cables to the inverter	Consult the number of inputs of the inverter system and the characteristics of the cable in its manual.

6 CONFIGURATION OF THE MASTER MCS UNIT

The unit must be configured according to the communication protocol with the inverter it is going to work with. There are two possibilities depending on the communication protocol with the inverter.

6.1 MODBUS TCP/IP COMMUNICATION PROTOCOL

The factory settings of the unit are valid. No action is required.

6.2 CAN BUS COMMUNICATION PROTOCOL

The unit is configured at CEGASA to work using this communication protocol with the following inverters:

- ✓ Solis S6-EH3P
- ✓ Solinteg-MHT
- ✓ Ingeteam Sun Storage 3Play 100TL

SIGNAL	PIN
CAN_H	4
CAN_L	5

With any other inverter in which the communication protocol is via CAN Bus, it will be necessary to modify the “pinout” of the card as follows:

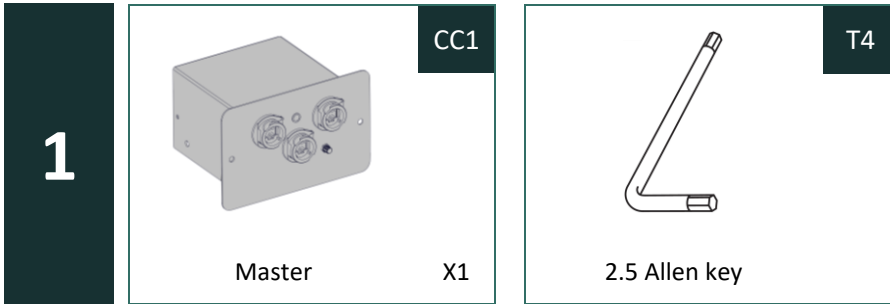

i Open the unit by loosening the four screws on the sides and carefully separating the cover. Remember that the card is connected to the cover.

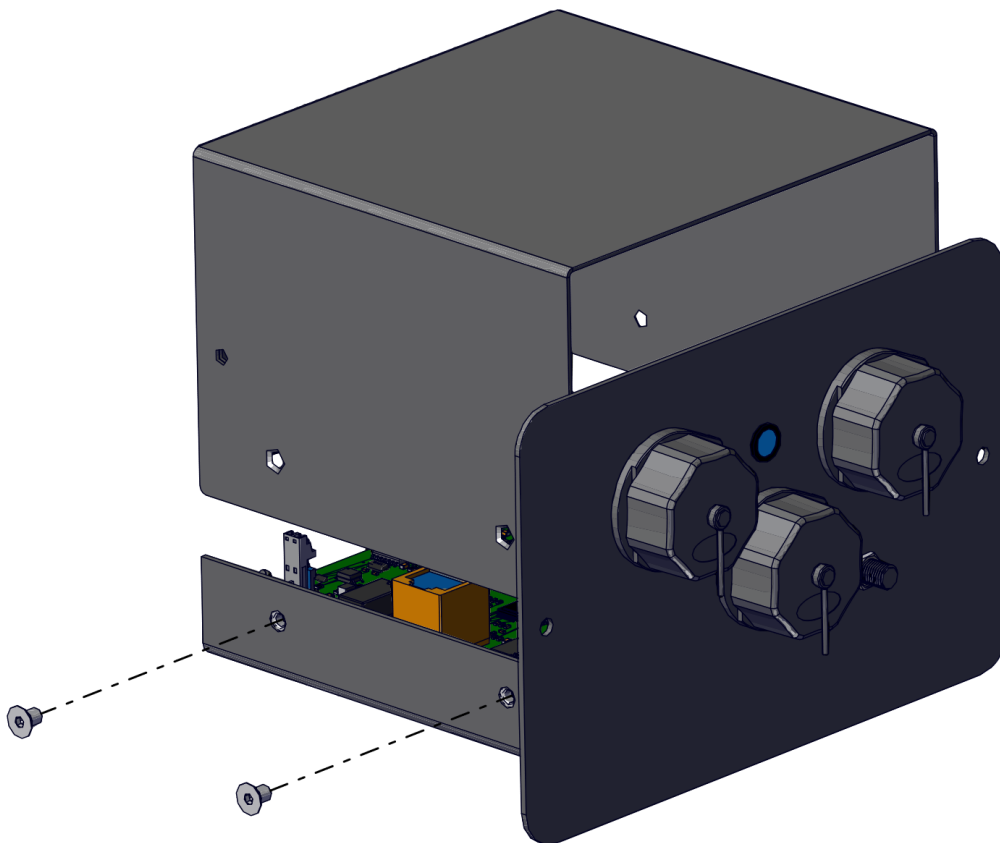

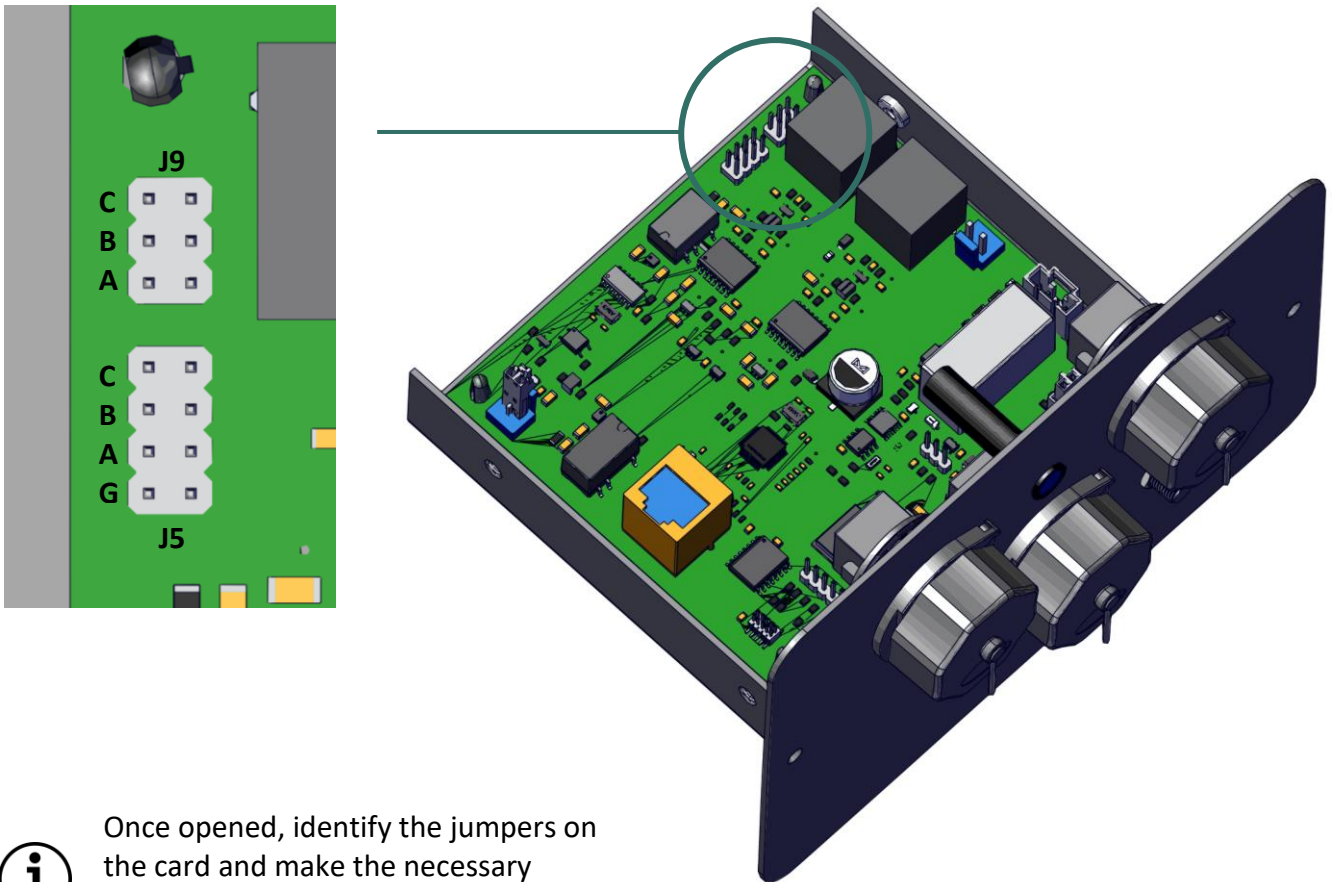

Once opened, identify the jumpers on the card and make the necessary changes according to the inverter to be used.

Inverter	J5	J9
Victron Multi HS19	CG	C
Selectronic SP PRO	A	A

Finally, close the unit again doing the first step in this chapter in reverse.

Then continue with HV EBick installation in Step 7 (p. 22).



Energy you can trust



CEGASA

Spain. Production Centre
Cegasa Energía S.L.U.
Parque Tecnológico de Álava, Calle Marie Curie 1
01510 Miñano, Vitoria-Gasteiz (Álava, Spain)

www.cegasa.com
hello@cegasa.com

+34 945 31 37 38