

# CEGASA

Energy you can trust



## E/Scal HV Home

### Installation Manual

Original manual  
Version June 2025



# Control of revisions

VERSION	DATE	DESCRIPTION
June 2025	17.06.2025	Content update

# Table of Contents

<b>1</b>	<b><u>Introduction .....</u></b>	<b><u>3</u></b>
1.1	<u>Purpose of the manual.....</u>	<u>3</u>
1.2	<u>Confidentiality .....</u>	<u>3</u>
1.3	<u>Safety during assembly.....</u>	<u>4</u>
1.3.1	<u>General .....</u>	<u>4</u>
1.3.2	<u>Mechanical .....</u>	<u>4</u>
1.3.3	<u>Fire prevention measures .....</u>	<u>5</u>
1.3.4	<u>Anti-electrolyte measures .....</u>	<u>5</u>
<b>2</b>	<b><u>Components.....</u></b>	<b><u>6</u></b>
2.1	<u>EScal HV Module (110054) .....</u>	<u>6</u>
2.2	<u>EScal BMU control unit (110055) .....</u>	<u>7</u>
<b>3</b>	<b><u>Necessary tools.....</u></b>	<b><u>8</u></b>
<b>4</b>	<b><u>Installation.....</u></b>	<b><u>9</u></b>
<b>5</b>	<b><u>Connections .....</u></b>	<b><u>22</u></b>

## 1 INTRODUCTION

---

Read this manual carefully to ensure the energy storage Battery System is properly installed. All these operations must be performed by a qualified and authorised technician.

### 1.1 PURPOSE OF THE MANUAL

This is the complete manual for the installation of the energy storage system made up of the following products.

Table 1-1. Glossary.

TERM	DEFINITION
<b>Module</b>	EScal HV Module.
<b>BMU</b>	EScal Home BMU control unit.
<b>Master</b>	Master MCS unit.
<b>Inverter</b>	Hybrid inverter.
<b>Tower</b>	Group of Modules stacked high.
<b>String</b>	Group of Modules connected in series and controlled by an EScal Home BMU control unit.
<b>Battery System</b>	Energy storage battery system.
<b>EViewer web app</b>	Battery System monitoring platform.
<b>CEGASA Cloud</b>	Cloud platform.

### 1.2 CONFIDENTIALITY

All the information provided by CEGASA ENERGIA SLU by virtue of this manual and any data or aspects that may become known as a result thereof will be absolutely confidential, and may not be provided to third parties or used for any purpose other than that intended, without the prior and express written authorisation of CEGASA ENERGIA SLU, (hereinafter CEGASA).

### 1.3 SAFETY DURING ASSEMBLY

The Battery System has been designed and tested in accordance with international safety standards. However, to avoid personal injury and property damage and ensure long-term operation of the Battery System, please read this section carefully and follow all recommended safety measures.

#### 1.3.1 General

- The area around the Battery System must be kept clear and free of combustible materials, petrol and/or other flammable vapours and liquids.
- Any air inlet or outlet in the room must be clear and free of obstacles.
- There must be no signs of deterioration in any component of the Battery System. Contact CEGASA with any questions.
- Do not access the interior of the BMU, or the Modules, or manipulate any internal components.
- Do not use or manipulate the Battery System components if your feet or hands are wet.
- Ensure that the output and input connection cables are not short circuited.
- Ensure that there is no short circuit between positive and negative terminals at any point.
- Follow the specifications proposed by CEGASA for the power and communications cables of the installation.
- Do not use, handle, install or store the Battery System in damp or very humid conditions.

#### 1.3.2 Mechanical

- The floor must be capable of holding the weight of the entire Battery System made up of one or multiple towers. The floor must be in optimal condition.
- Due to the weight of the Modules (>50 kg), they must be installed by two people.

### 1.3.3 Fire prevention measures

- Ensure there is a carbon dioxide extinguisher nearby.
- Do not use water to extinguish the fire.
- Full protective clothing and self-contained breathing apparatus are required for firefighters to extinguish the fire.

### 1.3.4 Anti-electrolyte measures

If the Battery System loses electrolyte due to a system malfunction, avoid contact with the leaking liquid or gas.

Electrolyte is corrosive and contact can cause skin irritation and chemical burns. In case of exposure to this substance, proceed as follows:

- Inhalation: Evacuate the contaminated area.
- Contact with eyes: Rinse eyes with cold water for 15 minutes.
- Contact with skin: Carefully wash the affected area with cold water and soap.
- Ingestion: Induce vomiting.

In any of the above cases, seek immediate medical assistance.

## 2 COMPONENTS

---

### 2.1 ESCAL HV MODULE (110054)

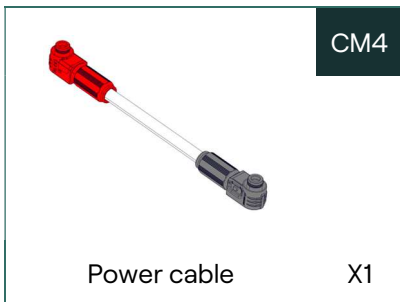
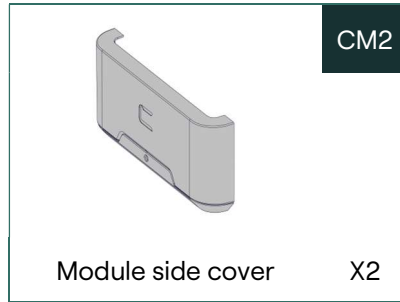
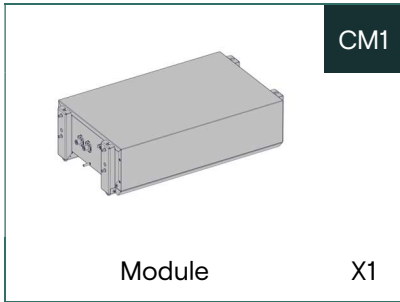

**2.2 ESCAL BMU CONTROL UNIT (110055)**

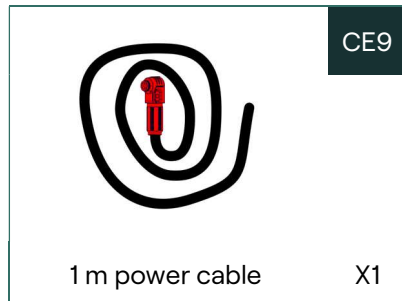
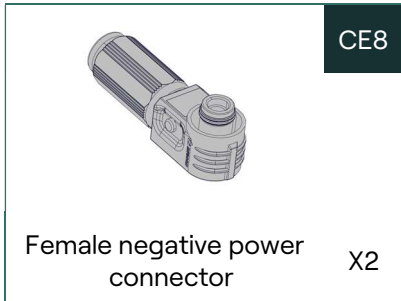
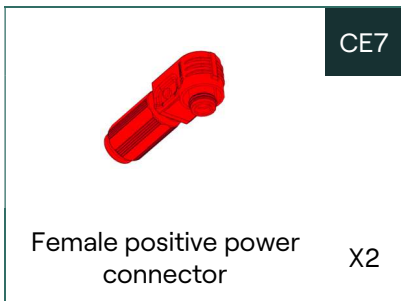
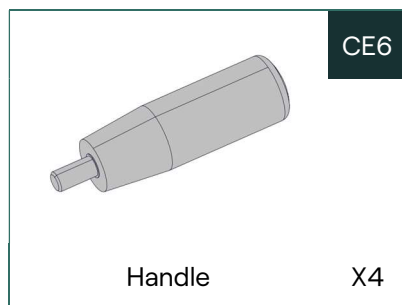
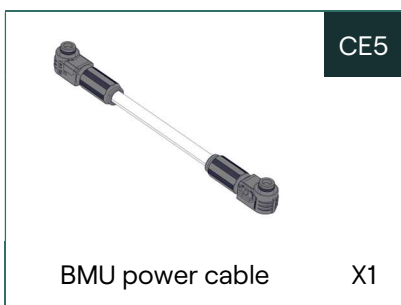
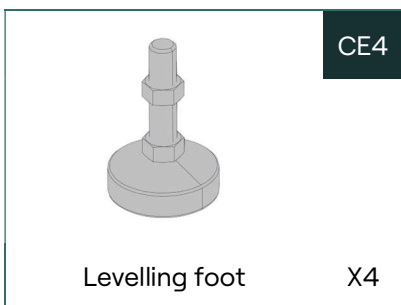
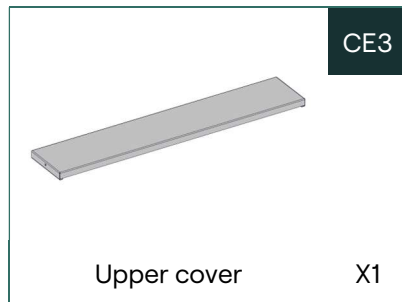
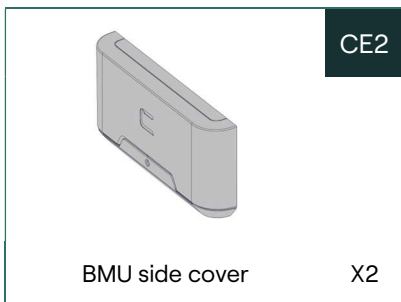
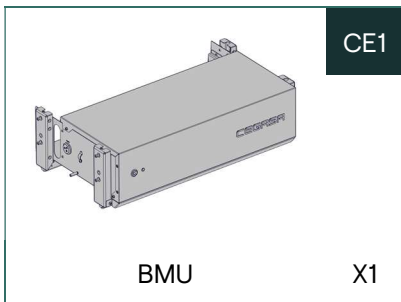

### 3 NECESSARY TOOLS

---

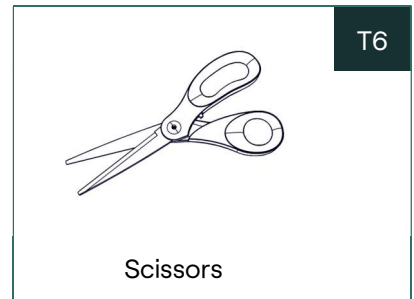
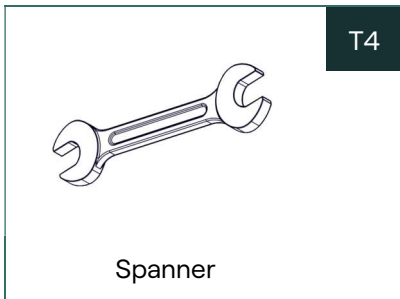
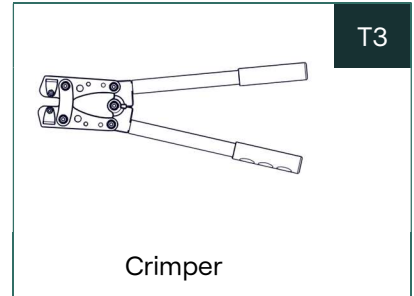
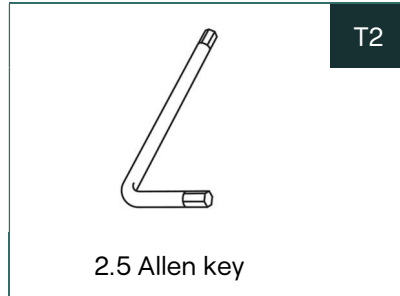

## 4 INSTALLATION

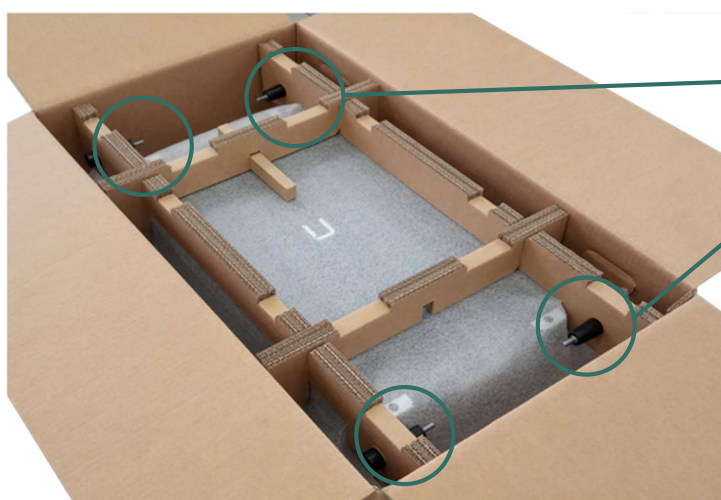
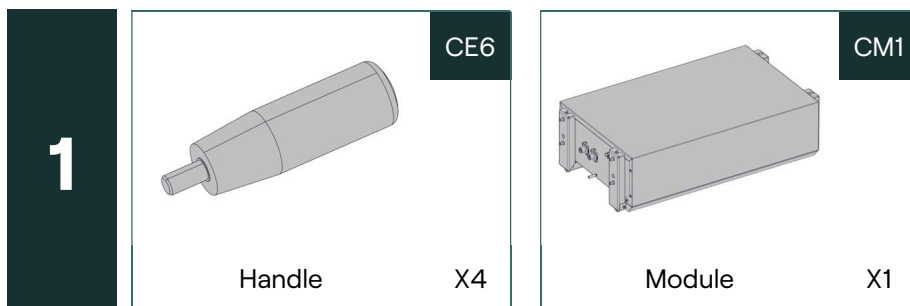

**i** The handles can be found inside the BMU box.

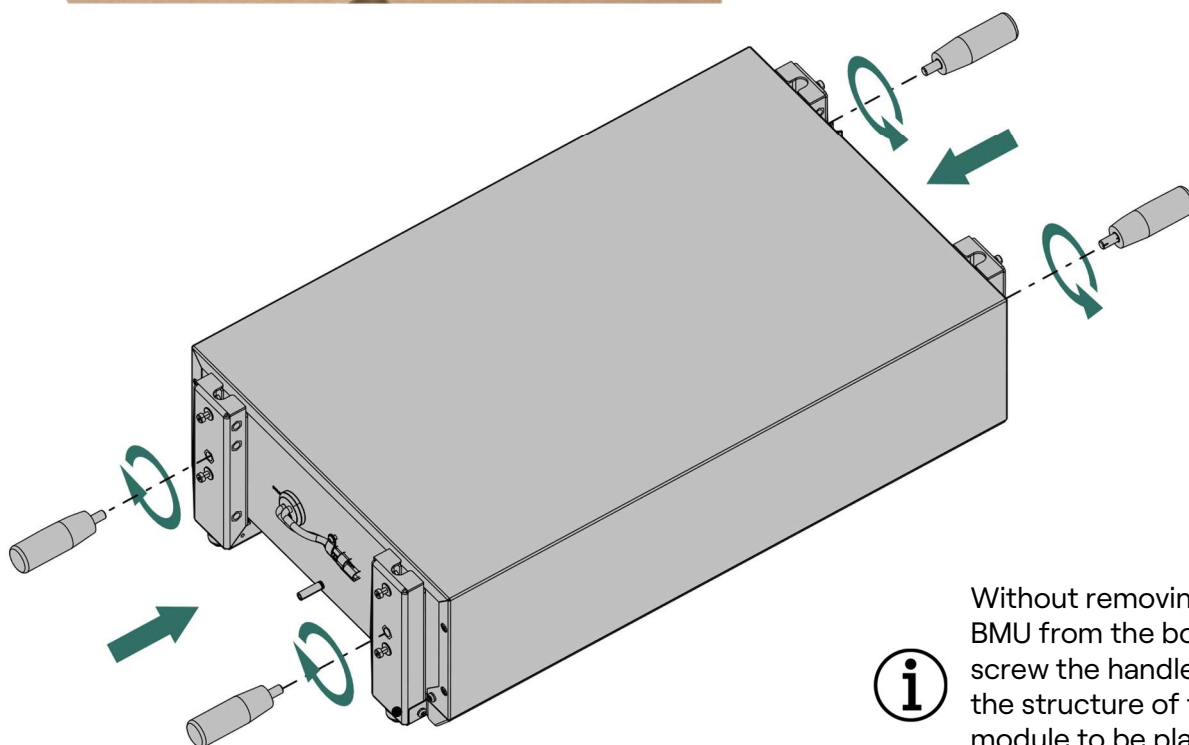

**i** Without removing the BMU from the box, screw the handles to the structure of the module to be placed on the ground.

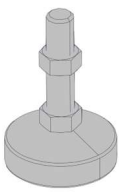
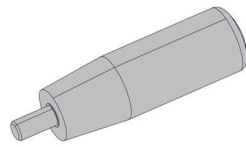
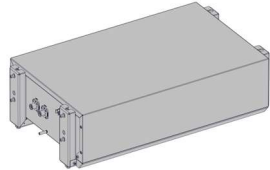
<b>2</b>	 Base X1	 Handle X4	 Module X1
	CE4	CE6	CM1



This step only applies to the first module.

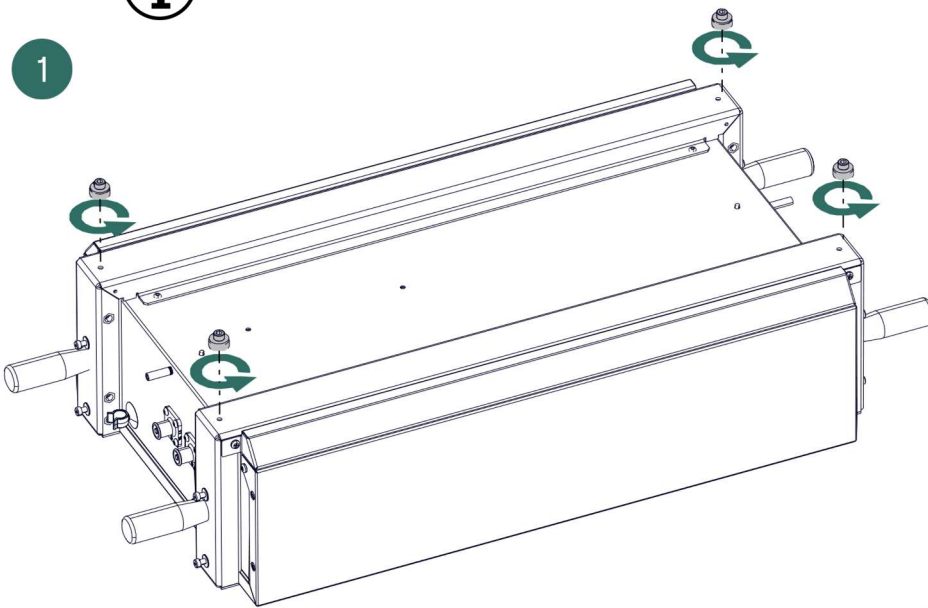

1

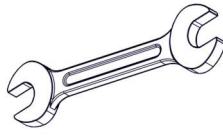

 Spanner	T4
--	----

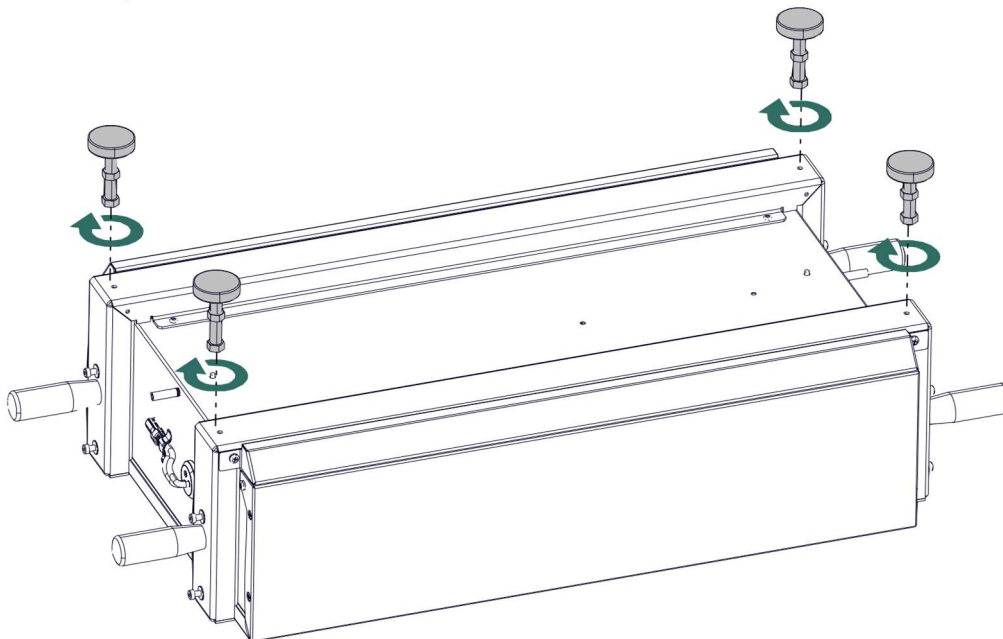
2

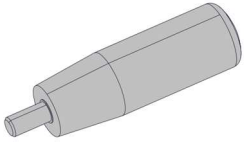
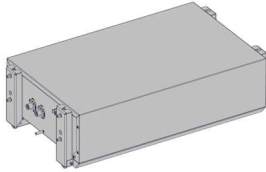

<b>3</b>	 Handle X1	 Module X1	 Spanner
----------	--	--	--

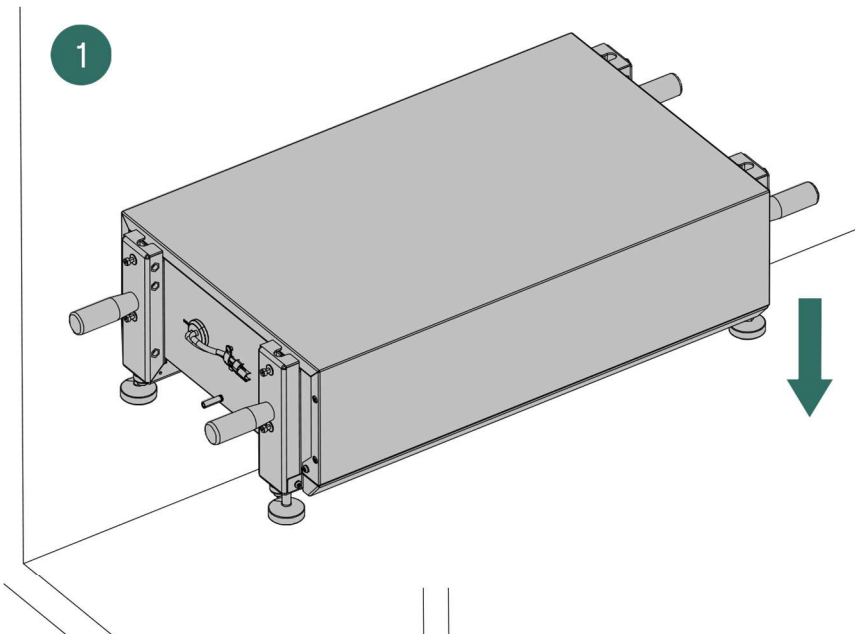

T1

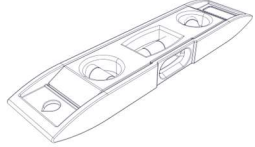

Spirit level

Step to be performed by two people. 

2

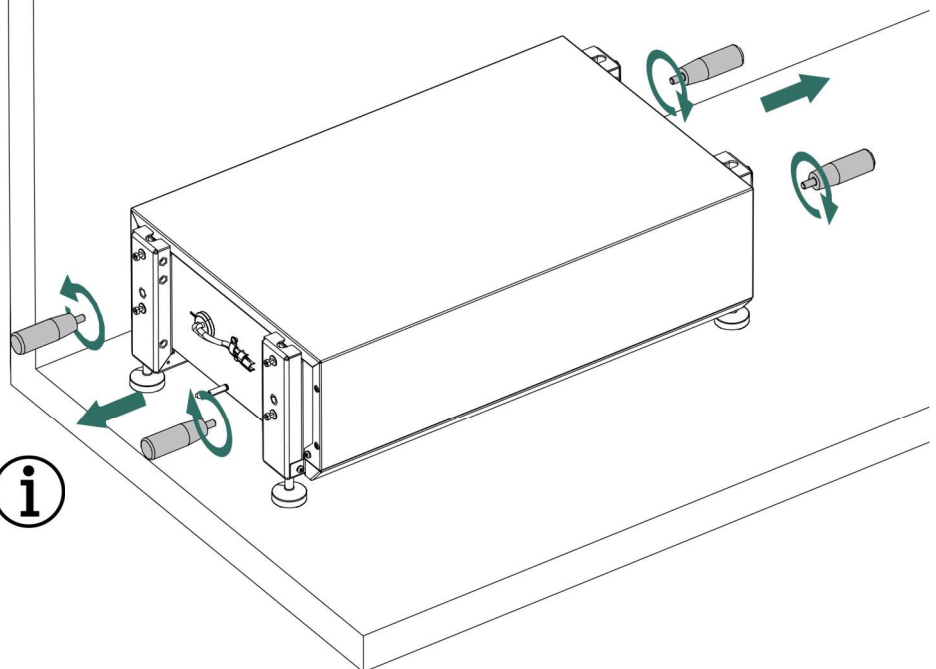

Check the levelling and adjust the feet if necessary.

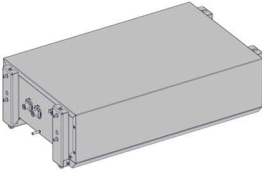
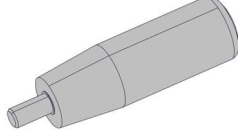

<b>4</b>	 <b>CM1</b>	 <b>CE6</b>
	Module X1	Handle X4

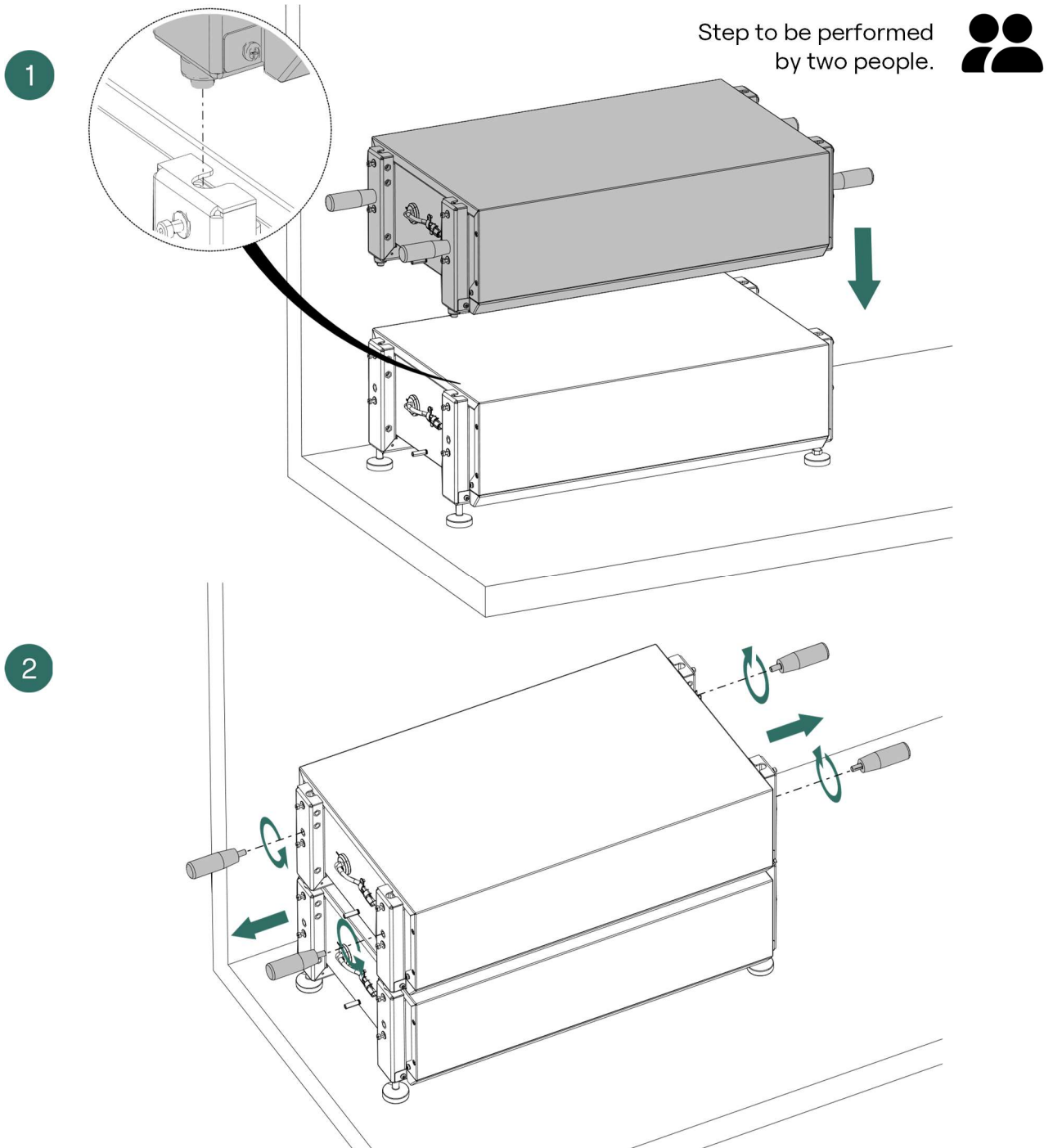

Place the desired number of Modules (2 to 4).  
The installation is the same as in the lower Module.

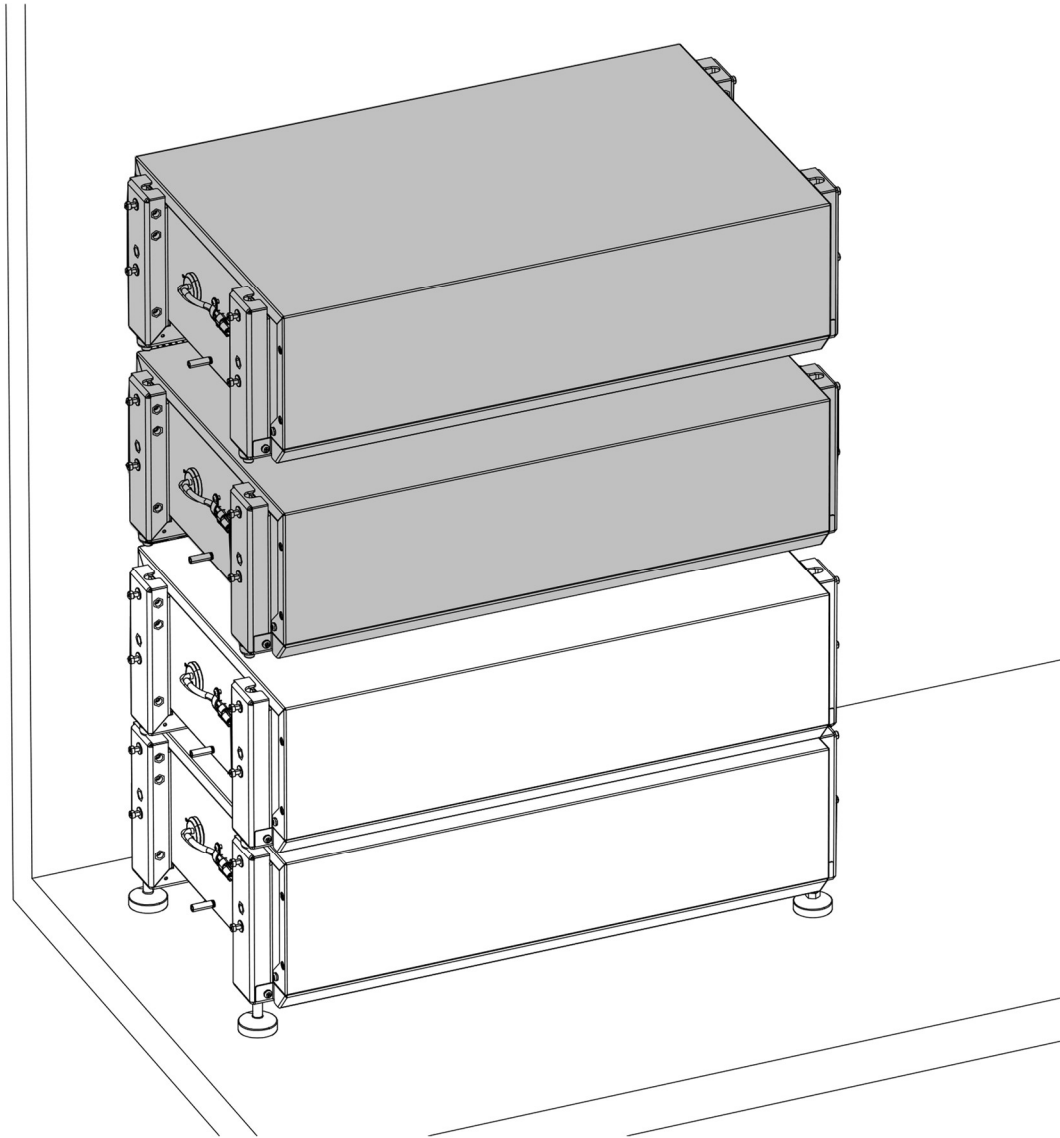

**5**

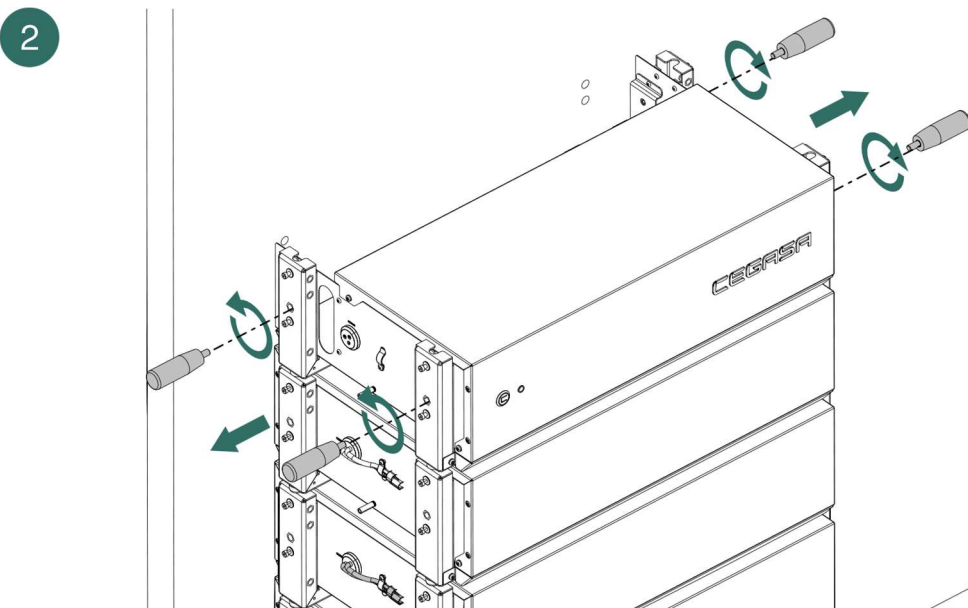
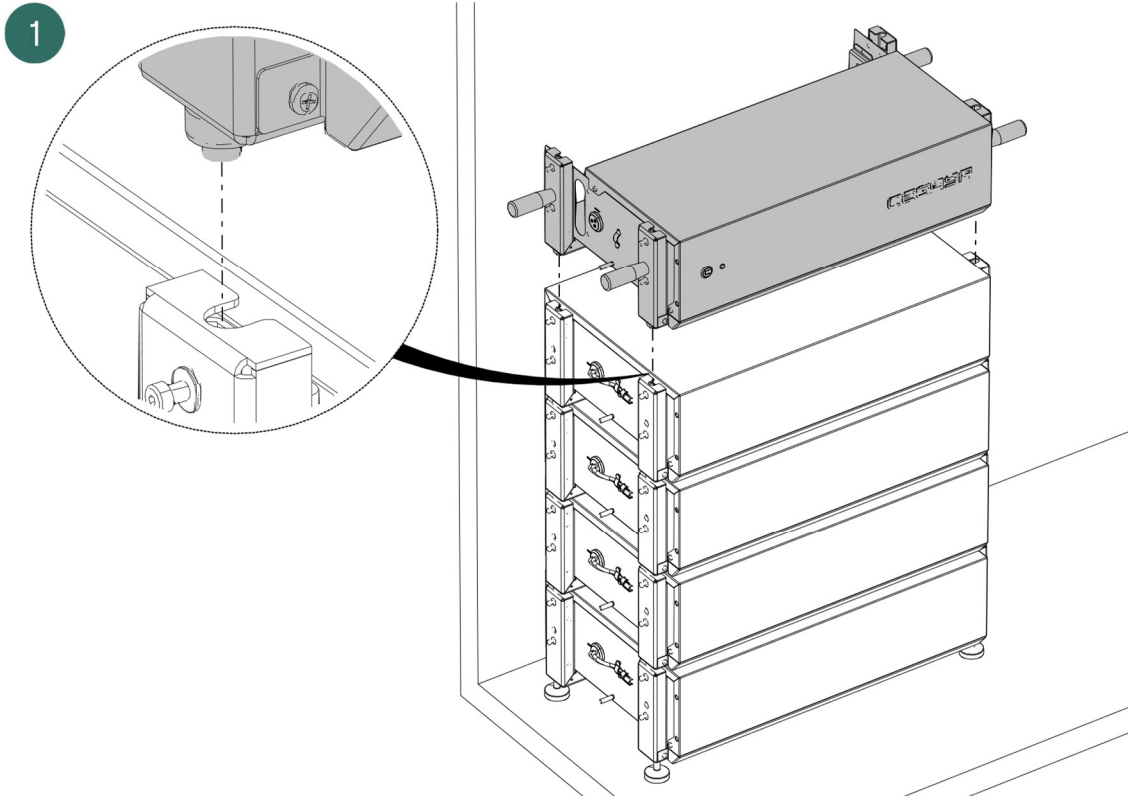
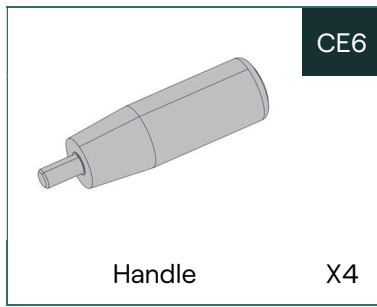
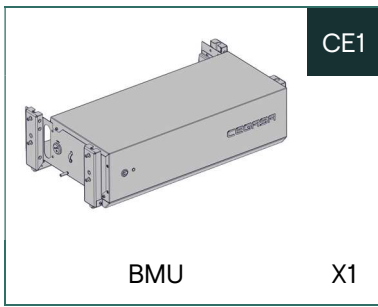

<b>6</b>	 Connection plate 2XN	 M6 Screw 4XN	 Torx T30 screwdriver
	CM3	CM5	T5



**IMPORTANT: ALWAYS fit the plates.**  
They act as a ground connection  
between the various modules.

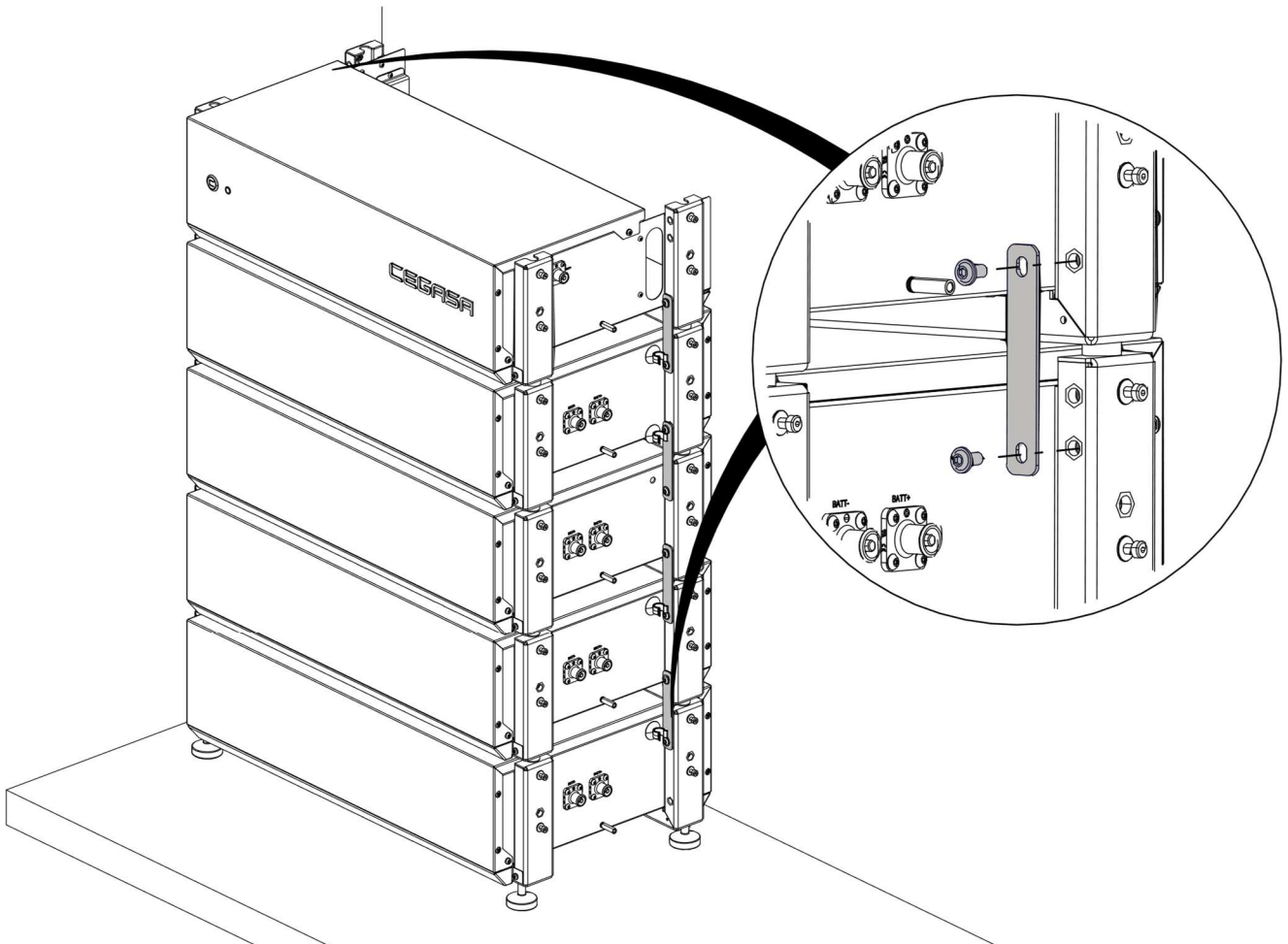

7

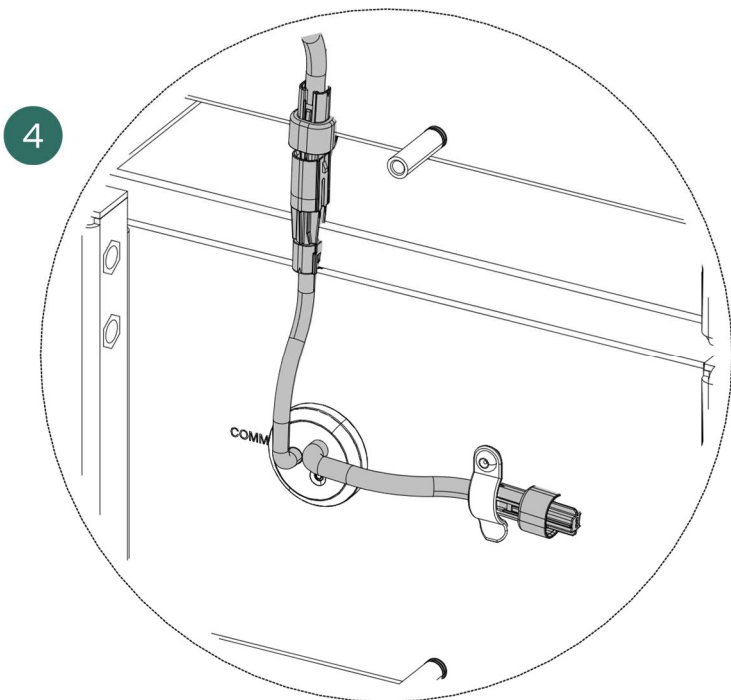
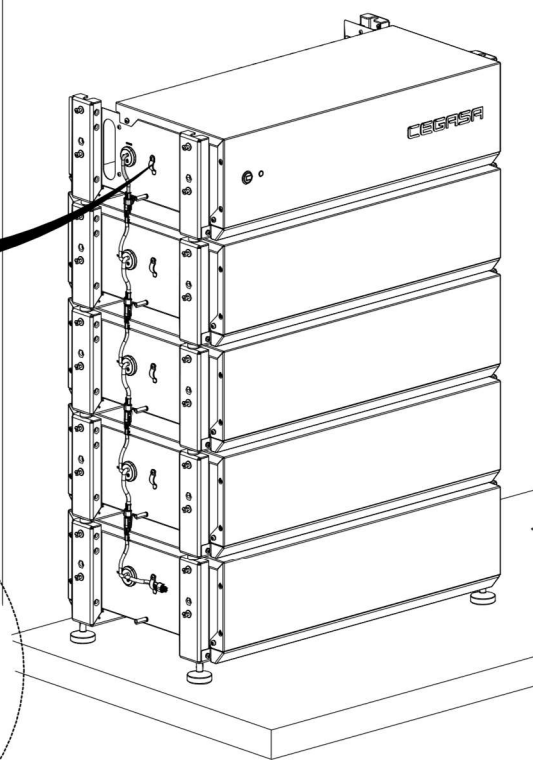
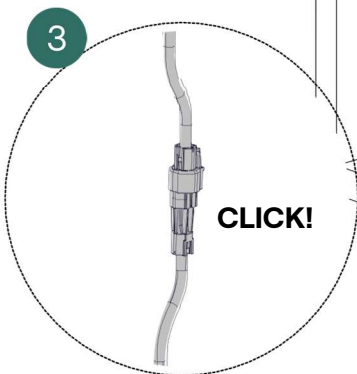
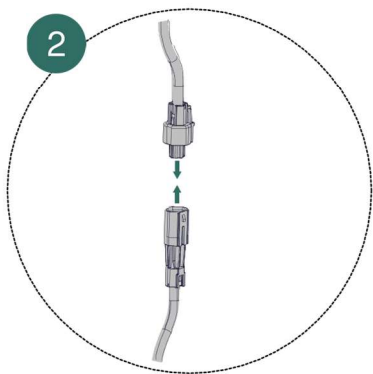
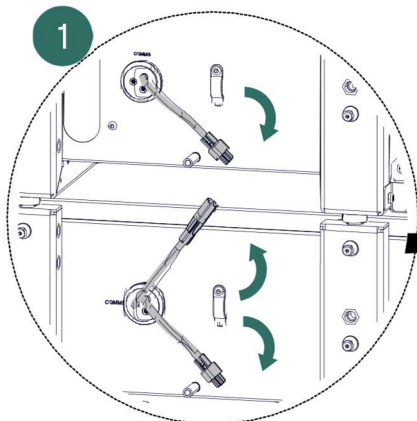

Work downwards on connections from the BMU and gather the cables together into the Module, ensuring they are in a vertical position.



The male COMMS cable from the last Module is not used. Leave it in the position shown in the figure.

8



CM4

Power cable X1



CE5

BMU power cable X1

Work downwards on connections from the BMU.

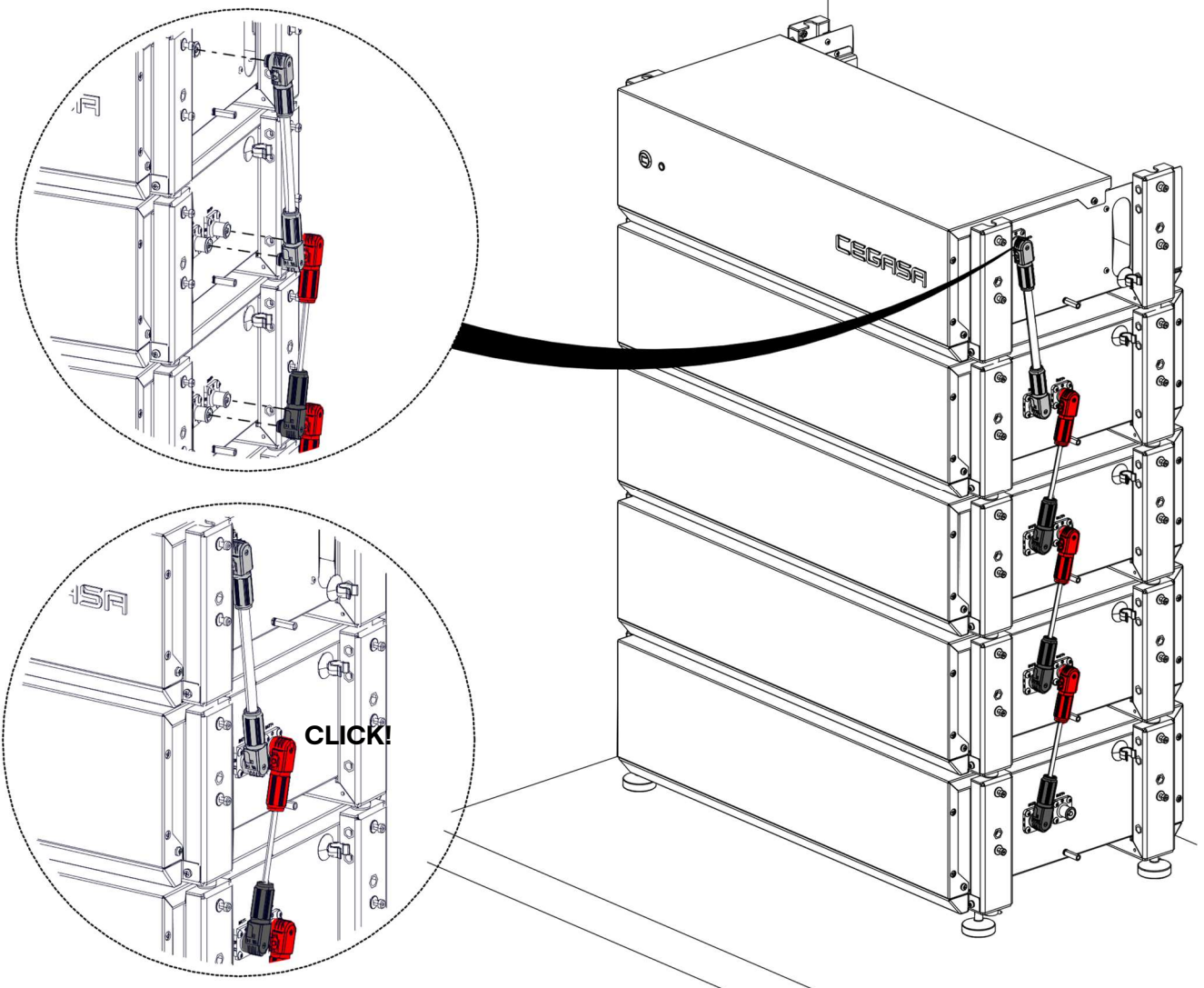

Place the heads with their corresponding connector:  
**Black = Negative**  
**Red = Positive**

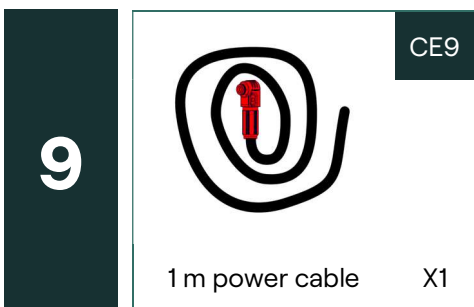

**i** The size of the cable will depend on the number of Modules that have been installed.

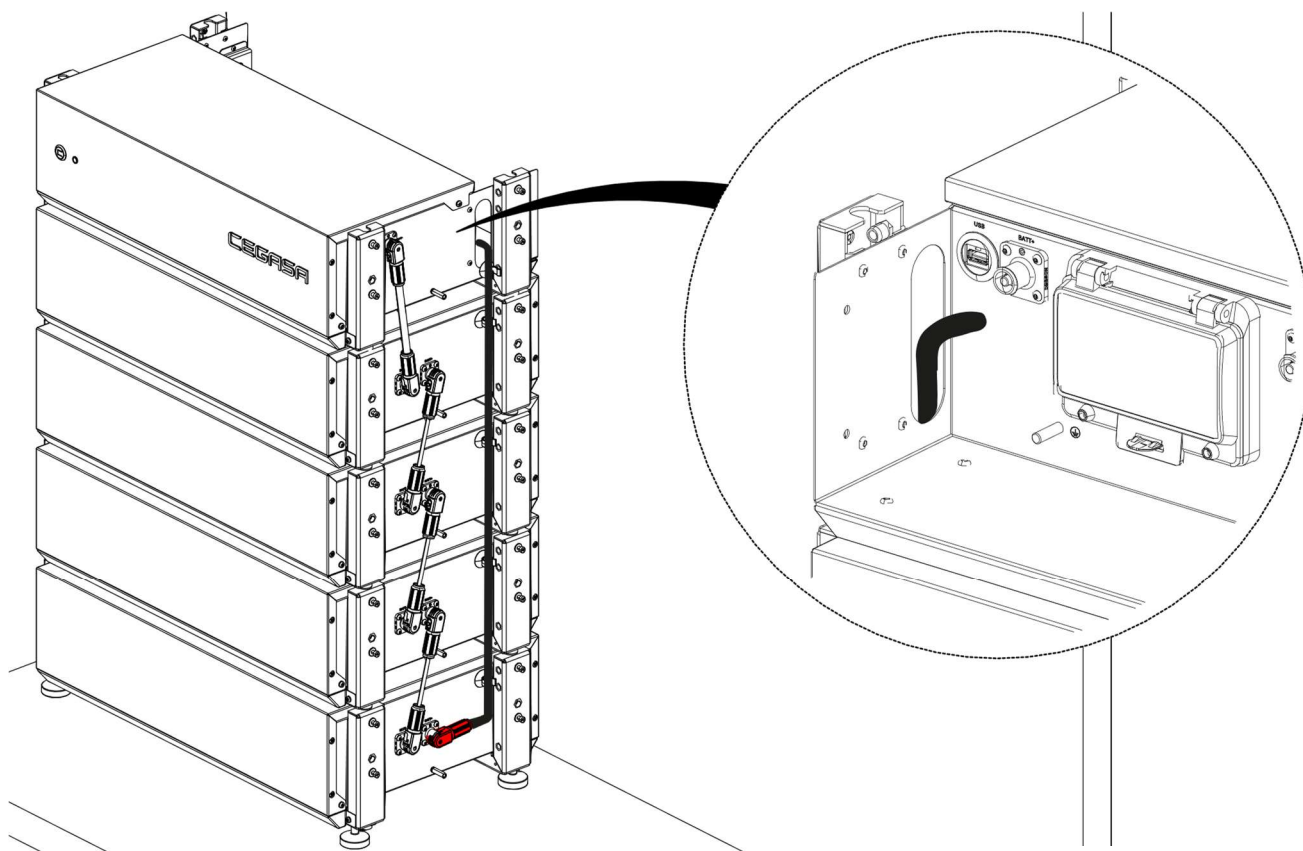

Cut the cable to the positive power input of the BMU. **i**

**!** Take the measurement when the cable is correctly placed in the clamps.

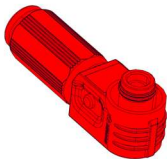
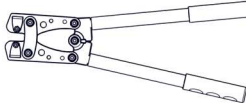
10		CE9	
	1 m power cable	X1	
		CE7	
	Female positive power connector	X1	
			T3
		Crimper	



Ensure that the **1 m power cable** is not connected to the Module before carrying out the following actions.

**1**

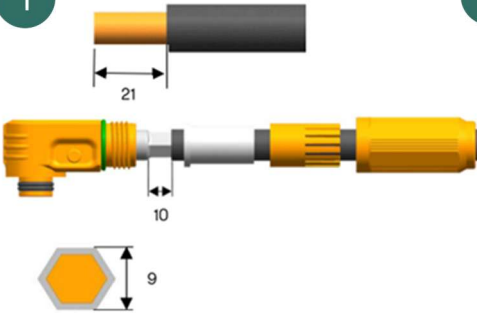

Crimp the positive aerial connector 21 mm (±1).

**2**



**3**



Check that the cable is well crimped. If in doubt, contact CEGASA.

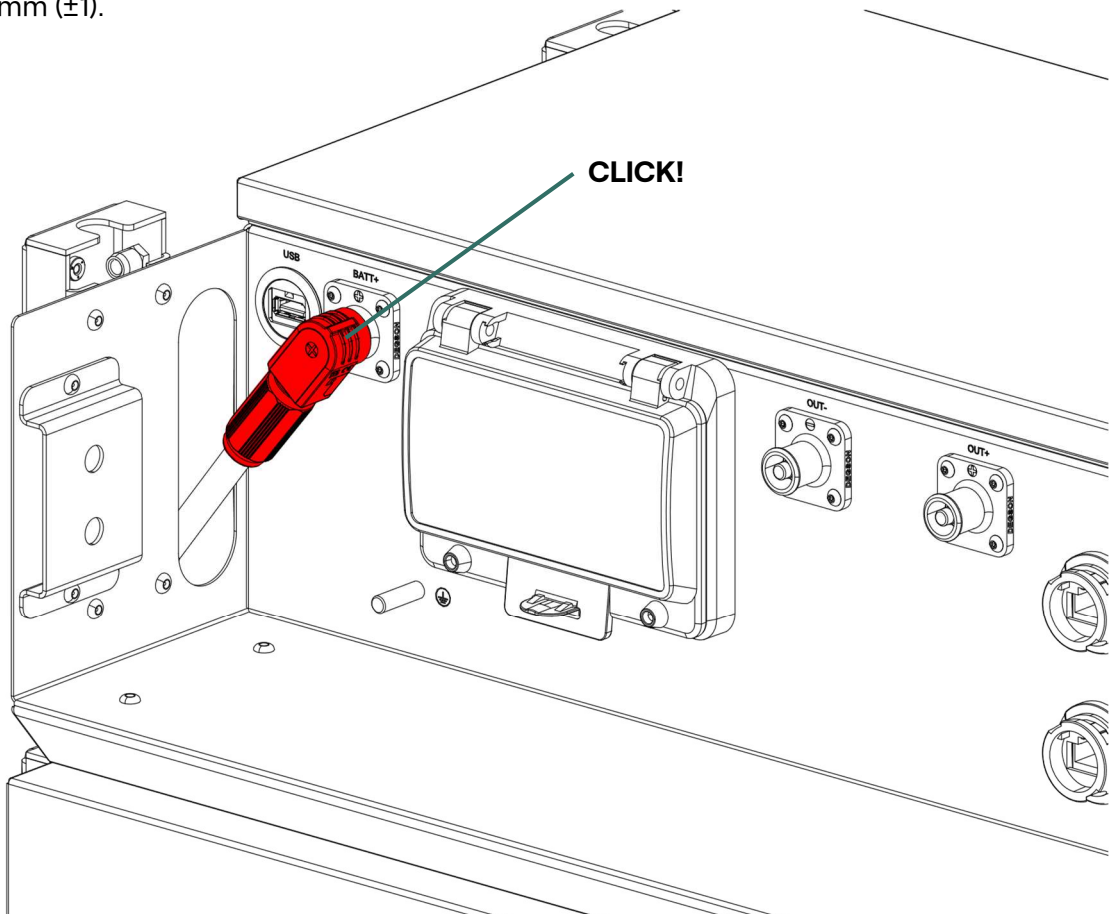

11

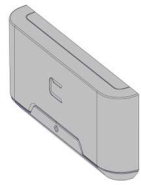

CE2

BMU side cover

X2

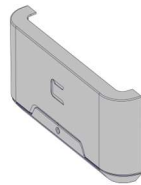

CM2

Module side cover

2XN



T2

2.5 Allen key

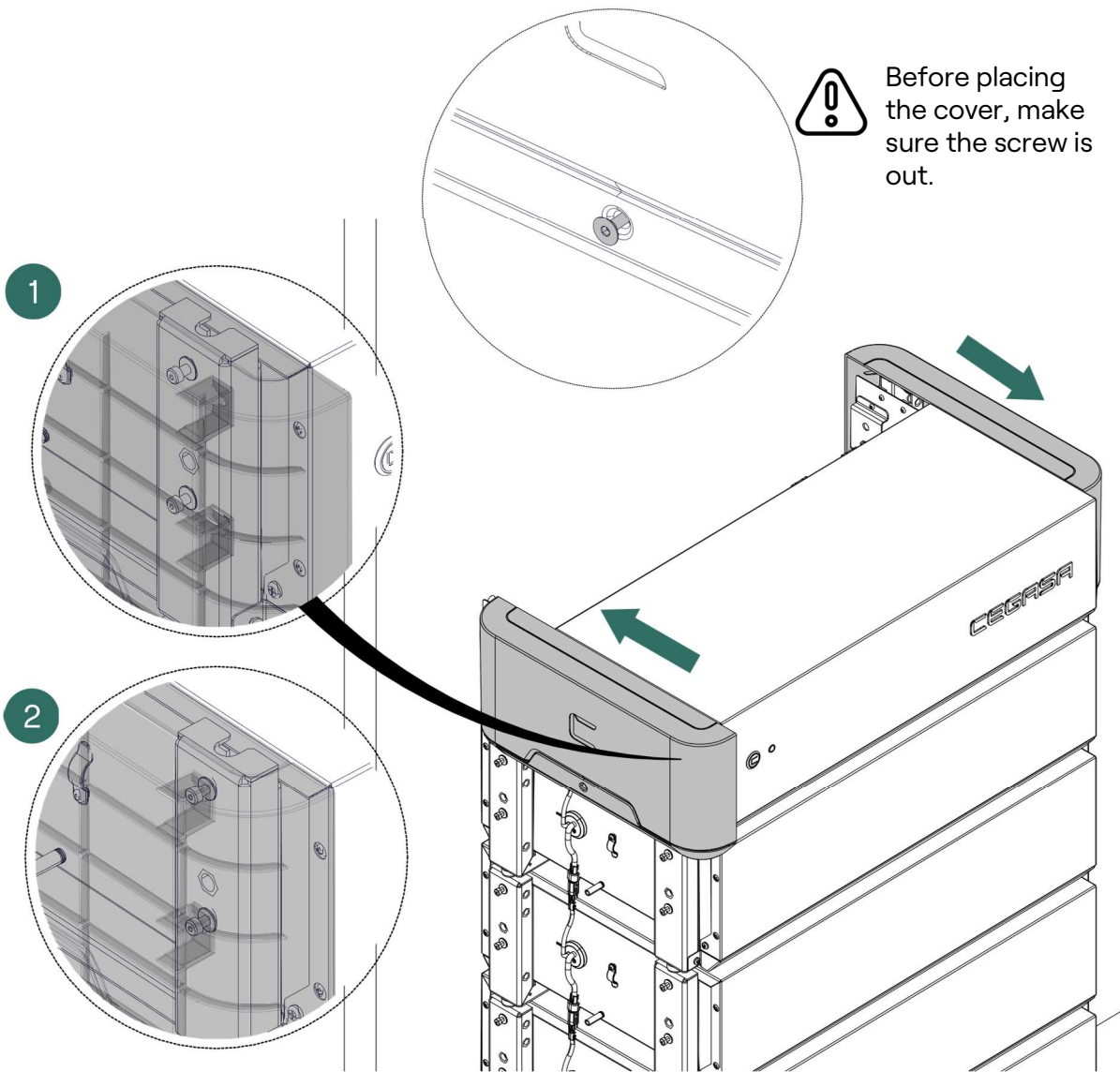

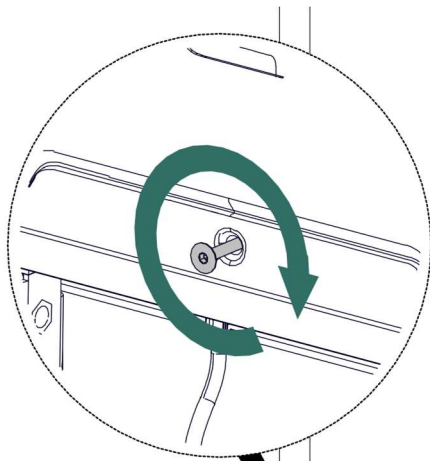

The cover and Module attachment screws are located inside the inner rails of the cover.

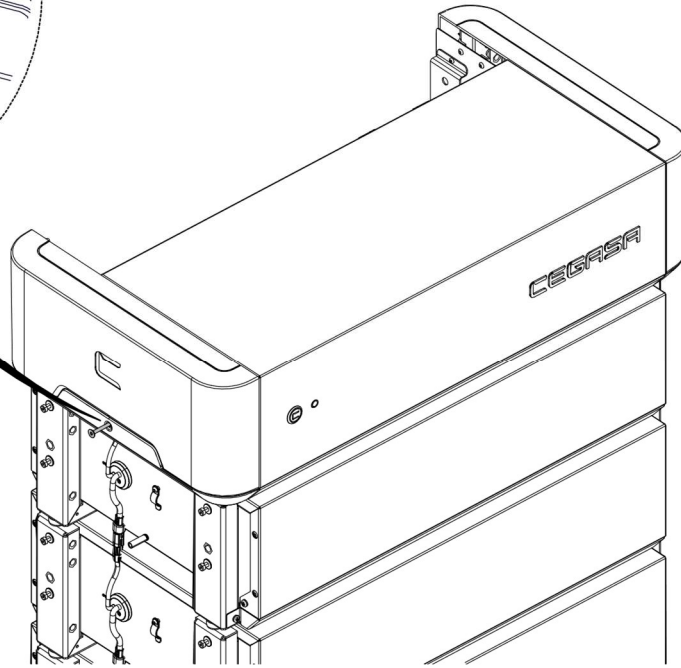

Place all the covers in the same way.

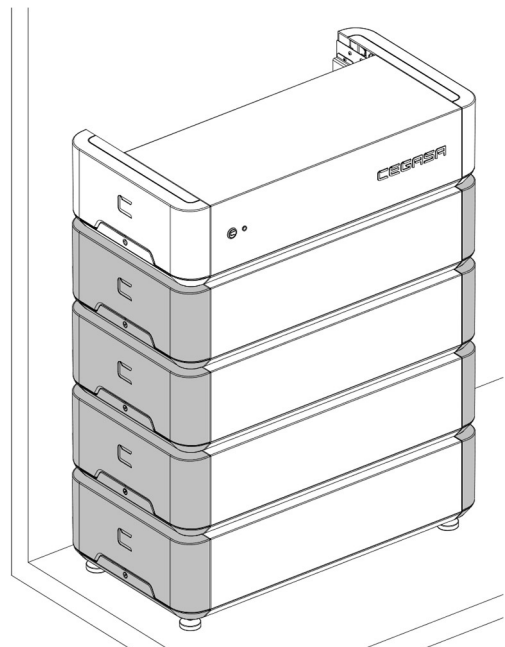

## 5 CONNECTIONS

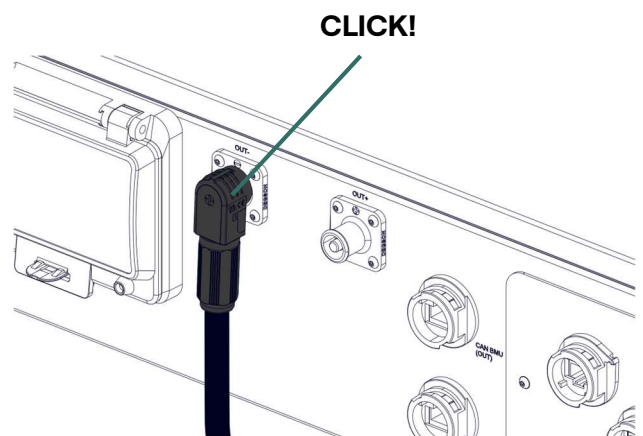
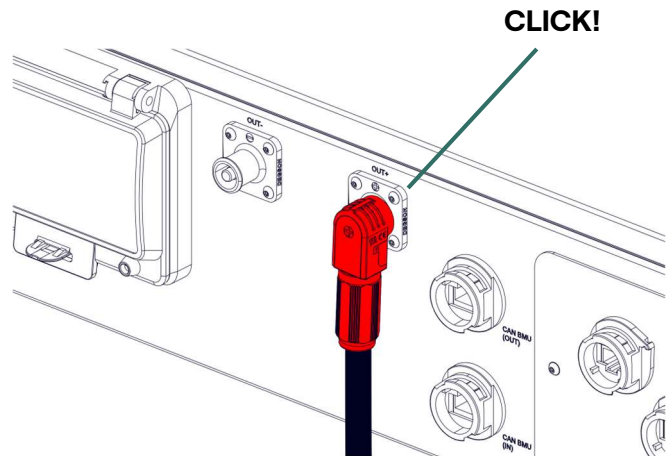

ITEM	TYPE OF CABLE	FEATURES
1	Inverter positive cable	1000 Vdc cable with 25 mm <sup>2</sup> section (not included).
2	Inverter negative cable	1000 Vdc cable with 25 mm <sup>2</sup> section (not included).
3	Inverter COMMS cable	Cat5e (min.) UTP cable, standard parallel (not included).
4	Earth cables	Earth cable with 10 mm <sup>2</sup> section (not included).

Before connecting,  
ensure that the main  
switch is down.

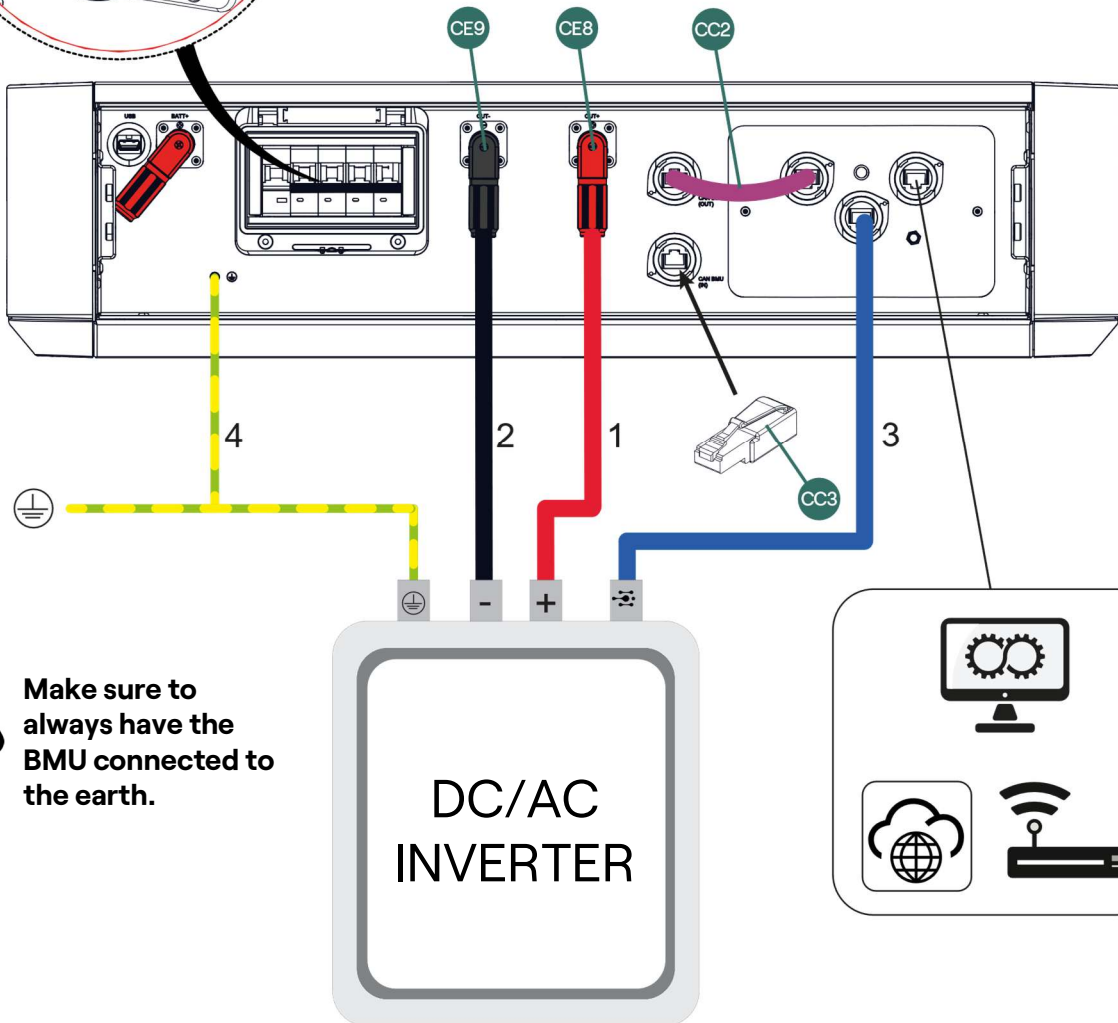
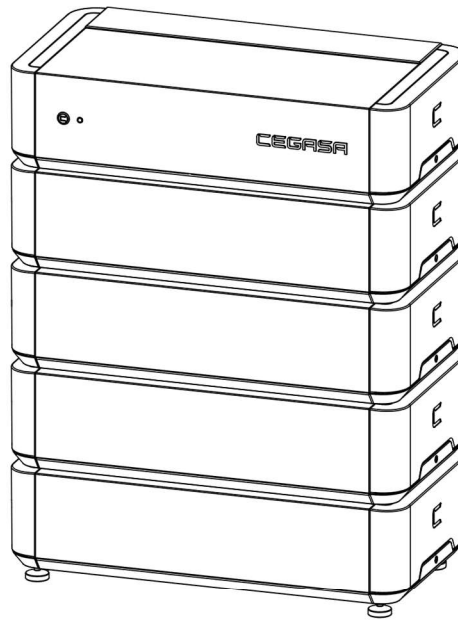
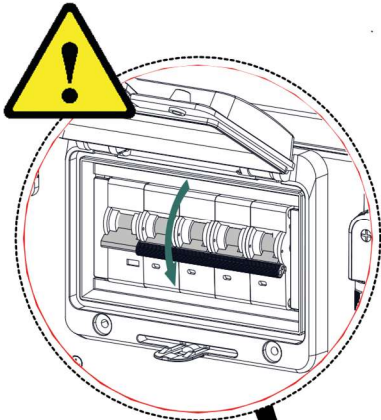

Make sure to  
always have the  
BMU connected to  
the earth.

Energy you can trust

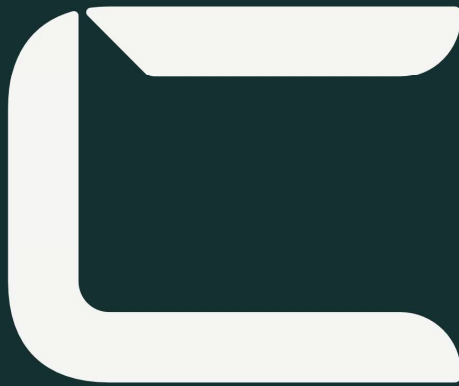

**CEGASA**

Spain. Production Centre  
Cegasa Energía S.L.U.  
Parque Tecnológico de Álava, Calle Marie Curie 1  
01510 Miñano, Vitoria-Gasteiz (Álava, Spain)

[www.cegasa.com](http://www.cegasa.com)  
[hello@cegasa.com](mailto:hello@cegasa.com)

+34 945 31 37 38