

CEGASA

Energy you can trust



E/Scal HV Home

User Manual

Original manual
Version June 2025

Control of revisions

VERSION	DATE	DESCRIPTION
June 2025	12.06.2025	Content update

Table of Contents

1	<u>Introduction</u>	<u>6</u>
1.1	<u>Purpose.....</u>	<u>6</u>
1.2	<u>Target.....</u>	<u>6</u>
1.3	<u>Page format.....</u>	<u>7</u>
1.4	<u>Symbols used.....</u>	<u>8</u>
1.5	<u>Acronyms.....</u>	<u>9</u>
1.6	<u>Language.....</u>	<u>9</u>
1.7	<u>Declaration of conformity.....</u>	<u>9</u>
1.8	<u>Limitation of warranties and liability.....</u>	<u>10</u>
1.9	<u>Confidentiality</u>	<u>10</u>
1.10	<u>Manufacturer information</u>	<u>10</u>
2	<u>Safety</u>	<u>11</u>
2.1	<u>Intended use</u>	<u>11</u>
2.2	<u>Rating plates</u>	<u>12</u>
2.3	<u>General information.....</u>	<u>13</u>
2.4	<u>Safety instructions.....</u>	<u>13</u>
2.4.1	<u>General.....</u>	<u>15</u>
2.4.2	<u>Mechanical.....</u>	<u>16</u>
2.4.3	<u>Fire prevention measures</u>	<u>16</u>
2.4.4	<u>Anti-electrolyte measures.....</u>	<u>16</u>
3	<u>Description of the system</u>	<u>17</u>
3.1	<u>Description.....</u>	<u>17</u>
3.2	<u>Line architecture</u>	<u>18</u>
3.3	<u>Main features</u>	<u>19</u>

3.4	Control architecture	20
3.4.1	BMS – Module	20
3.4.2	BMU – String.....	20
3.5	Interface - BMU.....	21
3.5.1	Front face.....	21
3.5.2	Rear face.....	21
3.5.3	Rear face.....	23
4	Processes and modes of operation.....	24
4.1	State machine description	24
4.1.1	Working state.....	24
4.1.2	States of protection	25
4.1.3	Operating modes.....	26
4.2	Equalisation.....	26
5	System configuration and start-up.....	27
5.1	EVIEWER connection	27
5.2	Powering the system	27
6	System operation.....	30
6.1	System start-up.....	30
6.2	System shutdown.....	31
6.3	Recommendations for use (charging and discharging)	32
7	Troubleshooting.....	33
8	System disassembly	36
9	Disposal system	38

10	<u>Transport and storage requirements and recommendations</u>	<u>39</u>
10.1	Shipment	39
10.2	Environmental requirements for use	39
10.2.1	Storage recommendations:	40
10.2.2	Deviations:	40
11	<u>Maintenance plan</u>	<u>41</u>
11.1	Maintenance plan	41
11.1.1	Training and Safety	41
11.1.2	Cleaning	41
11.1.3	Storage	41
11.1.4	Temperature	41
11.1.5	Regular Visual Inspection	41
11.1.6	Voltage control	41
11.1.7	Full charge	42
11.1.8	Deep discharges	42
11.1.9	Checking notices and alarms	42
11.1.10	Log and documentation	42
11.1.11	Updating firmware	42
11.2	Corrective maintenance plan	42
12	<u>Specific annexes</u>	<u>43</u>
A1	Warranty document	43
A2	CAN bus communications protocol	43
A3	MOD BUS communications protocol	43
A4	system configuration with the EViewer web app	43
A5	IP CONFIGURATION OF PC DEVICES	43

1 INTRODUCTION

1.1 PURPOSE

This complete manual provides the description, configuration, operation, and maintenance of the energy storage system made up of the following products.

Table 1-1. Glossary.

Term	Definition
Module	EScal HV Module.
BMU	EScal HV HOME BMU control unit.
Master	Master MCS unit. Included in the BMU.
Inverter	Hybrid inverter.
Tower	Group of Modules stacked high.
String	Group of Modules connected in series and controlled by an EScal HV HOME BMU control unit.
Battery System	Energy storage battery system.
EViewer web app	System monitoring platform for mobile devices.
CEGASA Cloud	Cloud platform.

1.2 TARGET

The instructions contained in this document can only be carried out by qualified people with the following skills:

- Knowledge of how Battery Systems work.
- Knowledge of how an inverter works and is operated.
- Knowledge of and compliance with applicable requirements, standards, and connection requirements.
- Knowledge of and compliance with this document and associated system documentation, including all safety instructions.
- Training to address the risks associated with the installation and operation of electrical equipment and batteries.
- Training in installation and commissioning of electrical equipment.

If this is not observed, the manufacturer's warranty and/or liability will be null and void unless it can be proven that the damage is not related to failure to comply with this requirement.

1.3 PAGE FORMAT

Each page of this manual has the following information.

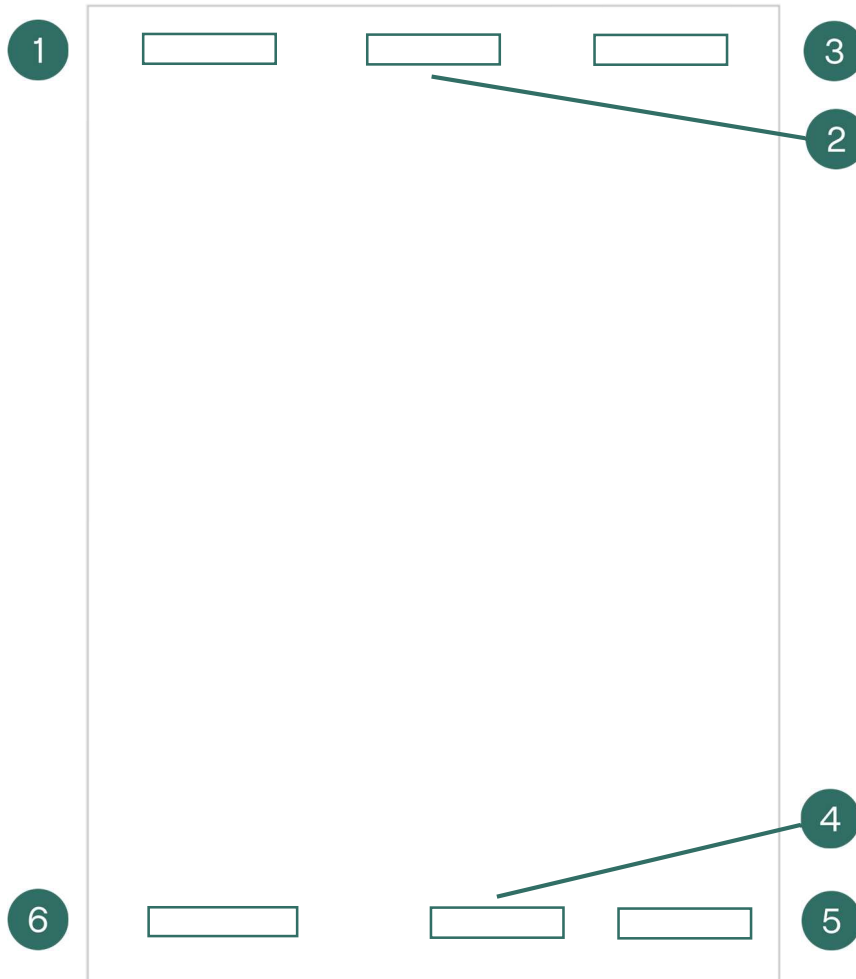

Figure 1-1. Page format.

Table 1-2. Page format.

Item	Description
1	Product name.
2	Manual name.
3	Revision of the manual.
4	Brand slogan.
5	Page number.
6	CEGASA logo.

1.4 SYMBOLS USED

The following information tables are used throughout this manual:

 DANGER!

Indicates a hazardous situation which, if not avoided, will result in death or serious injury.

 WARNING!

Indicates a hazardous situation which, if not avoided, may result in death or serious injury.

 CAUTION!

Indicates a hazardous situation which, if not avoided, may result in moderate or minor injuries.

 NOTICE

Information related to conditions, practices, or procedures that may pose a risk to machine integrity.

 INFORMATION

Information to bear in mind.

 ENVIRONMENTAL

Information related to conditions, practices or procedures that may pose a risk to the environment.

The following short notes can also be used to replace full-size notes:

 **Danger: Information related to conditions, practices, or procedures that pose a risk to individual safety.**

 **Warning: Information related to conditions, practices, or procedures that pose a risk to machine integrity.**

 **Caution: Information related to conditions, practices, or procedures that pose a risk to machine integrity.**

 **Notice: Information related to conditions, practices, or procedures that may pose a risk to machine integrity.**



Information: Information to bear in mind.



Environmental: Information related to conditions, practices or procedures that may pose a risk to the environment.

1.5 ACRONYMS

Table 1-3. Acronyms.

	Meaning
LFP	LiFePo4
BMS	Battery management system
SCS	String control system
SoC	State of charge
SoH	State of health
SoP	State of power
EMS	Energy Management System
PDC	Protection Distribution Cabinet
CB	Circuit Breaker

1.6 LANGUAGE

The original language of the equipment manufacturer is Spanish. Any other language in which the user manual is written is considered a translation from Spanish to the language used by the end user.

If any section or part of the translated manual is not clearly expressed or is not correctly understood, users have the manual in the original language of the manufacturer supplied together with the translated manual.

1.7 DECLARATION OF CONFORMITY

The Battery System described in this document complies with applicable European directives.

1.8 LIMITATION OF WARRANTIES AND LIABILITY

The limitation of warranties and liability will be described in the contractual agreements between CEGASA ENERGIA SLU and the purchaser (see Annex A1 Warranty document).

The information included in this manual has been written to provide users with the highest degree of detail and clarity on all the content. However, CEGASA ENERGIA SLU reserves the right to modify the content of this manual through future revisions at any time and without prior notice.

This document does not replace nor does it aim to replace any local, state, provincial, federal or national laws, regulations and codes applicable to the installation, electrical safety and use of the Battery System. CEGASA ENERGIA SLU assumes no liability for compliance or non-compliance with such laws or codes in relation to the installation of the Battery System.

1.9 CONFIDENTIALITY

All the information provided by CEGASA ENERGIA SLU by virtue of this manual and any data or aspects that may become known as a result thereof will be absolutely confidential, and may not be provided to third parties or used for any purpose other than that intended, without the prior and express written authorisation of CEGASA ENERGIA SLU, (hereinafter CEGASA).

1.10 MANUFACTURER INFORMATION

Contact CEGASA with any questions or queries at the following address:

Parque Tecnológico de Álava
Marie Curie 1, CP 01510 Miñano, Álava (Spain)
+34 945 228 469
info@cegasa.com
cegasa.com

2 SAFETY



DANGER!

The person responsible for the use of the system must ensure that anyone who operates the Battery System reads, understands and follows everything indicated in this user manual.

The Battery System has been designed and tested in accordance with international safety standards. Nonetheless, to avoid personal injury and property damage and ensure long-term operation of the system, please read this section carefully and follow all recommended safety measures.

2.1 INTENDED USE

The intended use of the Battery System is described below.

- It must only be used as stationary equipment.
- It can operate exclusively in on-grid and off-grid mode with compatible inverters. Consult with CEGASA for the list of compatible inverters.
- It can be connected to the internet via a network cable for monitoring, maintenance, and firmware update tasks.
- It is suitable for indoor use, never outdoors.
- Alterations to any of the components that make up the Battery System, for instance, changes or modifications, are not permitted without prior written authorisation from CEGASA. Unauthorised modifications will void the warranty and rights over it. CEGASA will not be responsible for any damage caused by such changes to the equipment.



DANGER!

The Battery System cannot be used for any other purpose than that described in this manual.

2.2 RATING PLATES



Figure 2-1. EScal HV module - Rating plate 1.



Figure 2-2. EScal HV HOME BMU control unit - Rating plate 1.

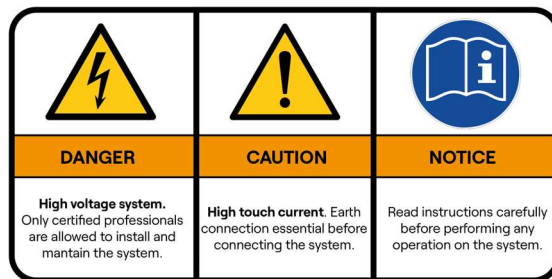

Figure 2-3. BMU - Rating plate 2.

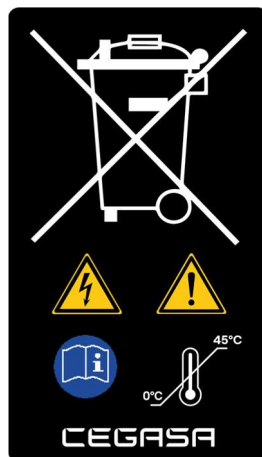

Figure 2-4. EScal HV module - Rating plate 2.

2.3 GENERAL INFORMATION

The entire Battery System has a high energy capacity. To minimise the risk of electric shock, short-circuit, explosion and/or fire, follow the relevant procedures and local guidelines, as well as the instructions set out in this manual.

To ensure that the Battery System is safe, all direct connections and terminals must be covered. Systems with visible electrical connections must also be isolated from public access.

Please read, understand and carefully apply the requirements indicated in this section.

2.4 SAFETY INSTRUCTIONS

NOTICE

Failure to follow safety instructions could result in serious injury, death or property damage.

DANGER!

The Modules must always be used with a CEGASA BMU control unit. Never connect the Modules without this unit.

To avoid high energisation currents, pre-charge the bus. A direct connection could damage the system. This pre-charge is managed from the BMU.

DANGER!

Before connecting the Battery System to the inverter, check that the voltage of the string formed by Modules connected in series is within the working range of the inverter.

DANGER!

Never open and eliminate, bypass or modify the cutting and protection systems included in the BMU.

DANGER!

Use safety tools (EN 60900) and protective equipment during installation and service to avoid short-circuits and electric shock.

 DANGER!

Do not expose the Battery System to room temperatures higher than 50°C. The equipment must not be operational above these temperatures. In fact, even when the equipment is not operational, the exposure of the cells to high temperatures can cause fire and/or explosion.

 DANGER!

Never drop or knock the Modules or the BMU.

 DANGER!

If using inverters, only use those authorised by CEGASA. Misuse of the Battery System during charging or discharging can cause premature ageing of the equipment or even fire and/or explosion. The communications of both units are complex and must be run by authorised specialised personnel.

 DANGER!

Do not open the covers of the Modules. Do not place or drop conductive objects inside the Module or between its terminals.

 DANGER!

Do not short-circuit the terminals (positive and negative) of the Modules or the BMU. The short-circuit current can be several thousand amperes, generating a dangerous electrical arc.

 DANGER!

Do not bring into contact or fully or partially submerge the Module in water or any other liquid.

 DANGER!

In case of fire, turn off the circuit breaker (CB) located on the rear of the BMU control unit and use a CO2 extinguisher or extinguishing agent recommended by local regulations to extinguish the fire. Do not try to put out the fire with water. The Modules contain flammable materials. Always notify firefighters about the installed Battery System.

 DANGER!

Ensure BMU control units are always properly grounded.

2.4.1 General

- The area around the Battery System must be kept clear and free of combustible materials, petrol and/or other flammable vapours and liquids.
- Any air inlet or outlet in the room must be clear and free of obstacles.
- There must be no signs of deterioration on any component of the Battery System. Contact CEGASA with any questions.
- Since it is a Battery System, whenever the contactors of the BMU control units are closed, there is high voltage between the output (+/-) terminals.
- Do not use the Modules if any of their parts have been totally or partially submerged in water or any other liquid. A water-damaged lithium cell is potentially dangerous. Attempts to use the Module could cause a fire or an explosion. In this case, contact CEGASA for an equipment inspection.
- Do not access the interior of the BMU, or the Modules, or manipulate any internal components.
- Do not use or manipulate the Battery System components if your feet or hands are wet.
- In the event of a fault or incident, cut off the power to the inverter as an initial measure.
- When a Module is not installed in the string, it must be ensured that the power terminals on the side are protected with their caps to avoid accidental contact, given that the positive and negative terminals are energised.
- Ensure that there is no short-circuit between positive and negative terminals at any point in the system.
- Follow the specifications proposed by CEGASA for the power and communications cables of the installation.
- Do not use, manipulate, install or store any of the components of the Battery System in damp or very humid conditions.
- Furthermore, a Battery System should never be installed in locations at an altitude of more than 2000 metres above sea level.

2.4.2 Mechanical

- The floor must be capable of holding the weight of the entire Battery System made up of one or multiple towers. The floor must be in optimal condition.
- Due to the weight of the Modules (>50 kg), they must be installed by two people.
- Do not stack more than 4 Modules per tower and always stack them on their feet.

2.4.3 Fire prevention measures

- Ensure that a CO₂ extinguisher or extinguishing agent recommended by local regulations is nearby.
- Do not use water to extinguish the fire.
- Full protective clothing and self-contained breathing apparatus are required for firefighters to extinguish the fire.

2.4.4 Anti-electrolyte measures

If the Module loses electrolyte due to a Battery System malfunction, avoid contact with the leaking liquid or gas.

Electrolyte is corrosive and contact can cause skin irritation and chemical burns. In case of exposure to this substance, proceed as follows:

- Inhalation: Evacuate the contaminated area.
- Contact with eyes: Rinse eyes with cold water for 15 minutes.
- Contact with skin: Thoroughly wash the affected area with cold water and soap.
- Ingestion: Induce vomiting.

In any of the above cases, seek immediate medical assistance.

3 DESCRIPTION OF THE SYSTEM

3.1 DESCRIPTION

The EScal HV HOME line is a European-manufactured Battery System for the stationary environment with LFP technology, providing optimum quality, service, safety and cyclability.

The line consists of the following parts:

Parts	Measurements (mm)	Weight (kg)
EScal HV Module	706x375x180	51
EScal HV HOME BMU control unit	706x375x180	18

1. EScal HV Module (57.6 V – 100 Ah; 5.8 KWh)

Designation according to standard (IEC 62620:2014); IFpP53/149/120[1p18s]M/-20+55/90

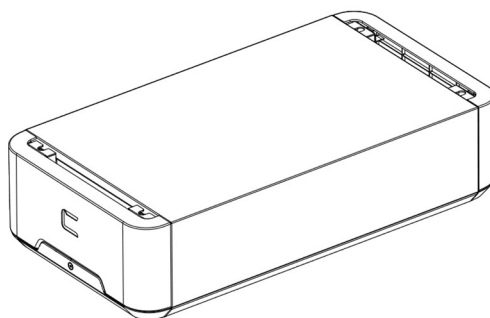

Figure 3-1. EScal HV Module.

2. EScal HV HOME BMU control unit

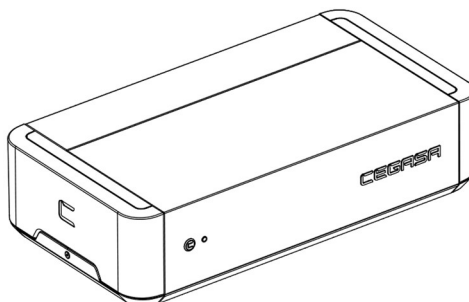

Figure 3-2. EScal HV HOME BMU control unit.

3.2 LINE ARCHITECTURE

The EScal HV HOME line is based on two connection levels:

1. **Tower.**

A maximum of 4 Modules can be stacked in a tower (always on the feet included in the BMU box). The tower is not operational or functional without the BMU control unit.

2. **String.**

A set of Modules (2 to 4 Modules) connected in series, controlled by a BMU, with connectivity provided by a Master unit inside the BMU.



Figure 3-3. String with 4 Modules and a BMU.

3.3 MAIN FEATURES

- Modular design. A string can be made up of 2 to 4 Modules connected in series and controlled by its BMU.
- The Modules can be stacked on their base up to a maximum of 4. Power and communications connections are made on the sides with quick and safe connectors (without the need for tools). Once made, all connections are concealed to make the system safer and more aesthetic.
- Compatible with the most relevant high voltage inverters (single-phase and three-phase) on the market. CAN BUS or MODBUS communications depending on each inverter.
- IP55 protection.
- Automatic recognition of Modules in the installation by the BMU.
- Start and stop with LED ON/OFF button on the front, and with a controlled DC bus pre-charging system.
- Protections for short-circuits, overcurrent, voltages, temperatures...
- Simple system, designed to facilitate the disassembly and repair of electronic components.
- Wi-Fi module to facilitate local communications with its own application for configuration, management, data analysis, etc.
- Remote diagnosis with the EViewer web app developed by CEGASA.

3.4 CONTROL ARCHITECTURE

CEGASA's EScal HV HOME line offers a modular and scalable system that adapts to the voltage and energy requirements of its intended use. For this, the system has a two-level control architecture: Module (BMS), String (BMU).

3.4.1 BMS – Module

At this level, both the unit voltages of each cell and their temperatures at various points are recorded and sent via an ISO SPI communications bus to the next higher control level (BMU).

3.4.2 BMU – String

Each group of Modules connected in series (called a string) is connected both in power and communications to the BMU.

The function of the BMU is to provide each group of Modules (connected in series) with the necessary short-circuit and overload protections (voltage, current, temperature), perform the safe connection/disconnection of said string, perform thermal management, estimate Module group variables, manage alarms and, finally, manage the equalisation of the various Modules. For this it also has protection elements and electronics that perform this management based on the value of the variables obtained from the BMS.

The Master MCS unit is inside the HV HOME BMU. Electronics that enable system connectivity and allow communication between the inverter, CEGASA Cloud, EViewer platform and EMS.

The Master unit has two communication protocols to communicate with different inverters and EMS: CAN bus and Modbus TCP/IP.

Connection with the CEGASA Cloud and the EViewer web app can be made by both using the ETHERNET port (cable) and wirelessly via Wi-Fi connectivity.

The Master unit configures the cards of each BMU, sends the connection/disconnection commands and aggregates the variables of each string.

3.5 INTERFACE - BMU

As detailed, each string of Modules must be connected to its control with a BMU. The interfaces of the BMU are detailed below.

3.5.1 Front face

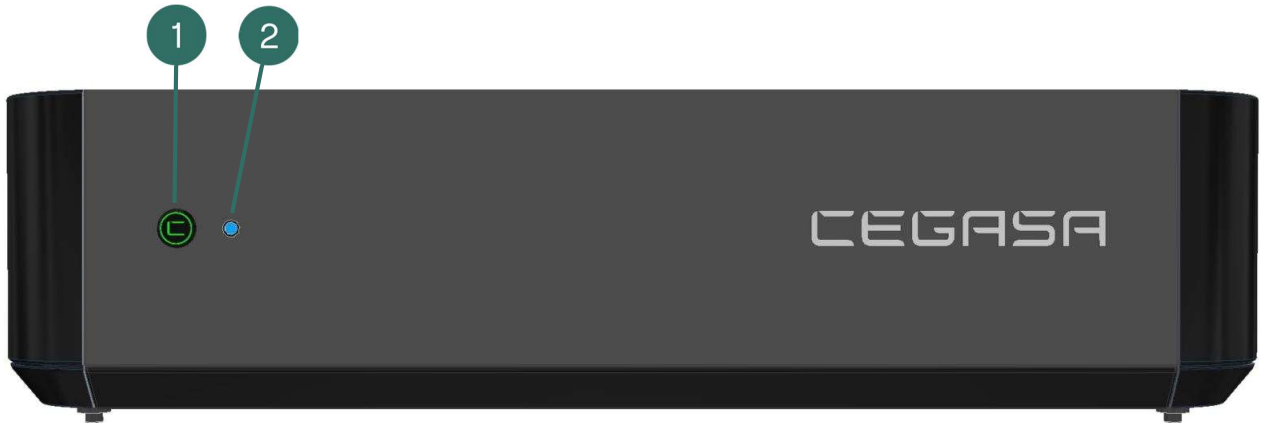

Figure 3-3. BMU front.

3.5.2 Rear face

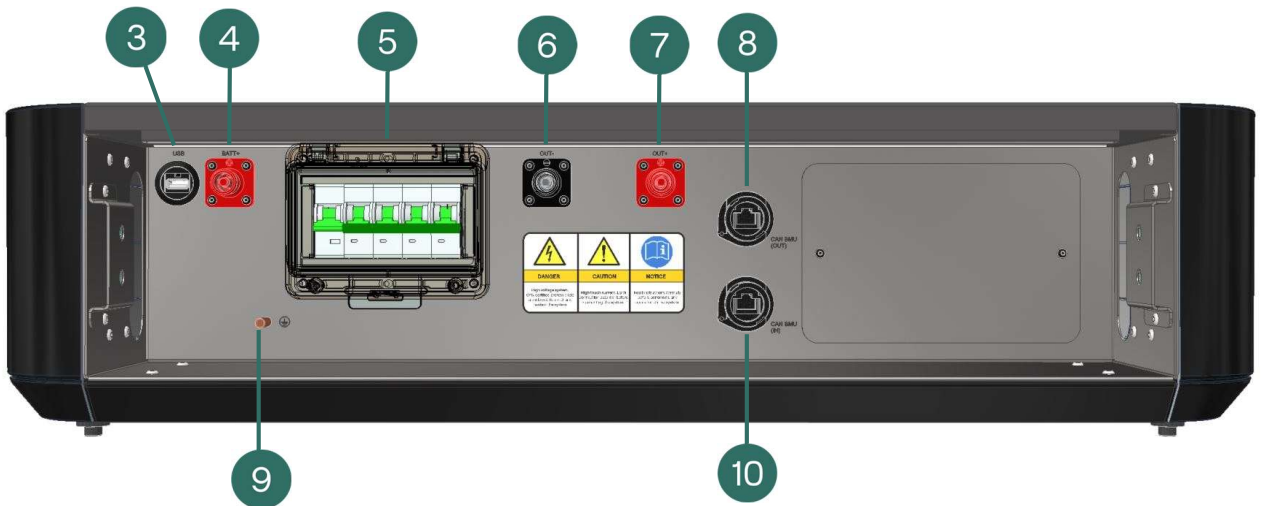

Figure 3-4. BMU rear.

Table 3-1. BMU interface front and rear.

Item	Name	Description
1	Start/stop button	Button for closing the string contactor. Includes two-colour (red/green) LED to indicate the status of the string.
2	Mode LED	LED indicating the operating mode of the string.
3	USB	Connector to update system via USB (in some versions).
4	BATT+	Positive pole power connection of the string.
5	Circuit breaker (CB)	Thermal magnetic circuit breaker. To connect/disconnect the string. It adds overcurrent and short-circuit protection.
6	OUT-	Negative pole power connection from the string to the inverter.
7	OUT+	Positive pole power connection from the string to the inverter.
8	CAN BMU (Out)	CAN bus output connector.
9	Earth	Earth connection.
10	CAN BMU (In)	CAN bus input connector.

3.5.3 Rear face



Figure 3-5. BMU rear with the Master unit.

Table 3-2. Master unit interface.

Item	Name	Description
11	CAN BUS BMU	CAN bus connector to connect the EScal HV HOME BMU.
12	Mode LED	LED indicating the operating mode of the Master.
13	ETHERNET	Ethernet and Modbus TCP/IP connector.
14	CAN BUS INVERTER	CAN bus connector to connect to the inverter.
15	ANTENNA	MCS Wi-Fi connection antenna

4 PROCESSES AND MODES OF OPERATION

4.1 STATE MACHINE DESCRIPTION

The Battery System has different ways to show the state it is in at all times. Users will be able to connect to them through the EViewer web app where they will find detailed information about it. The BMU also integrates light indicators with different codes detailed below.

4.1.1 Working state

The Battery System passes through different states depending on the system’s work mode. The light indicator on the start/stop button modifies its emission code depending on the state of the string.

Each of the possible states is described below:

 INFORMATION







The LED flashes slowly.



The LED flashes quickly.

Table 4-1. Single string states.



LED button	State	Description
	Start-up	When the BMU is switched on by arming the rear circuit breaker (CB) (up position), the internal start-up process begins (yellow LED). Once started and enabled by the Master, the system shifts to the next state, Ready .
	Ready	From the Ready state, users can close the BMU contactor by pressing the start/stop button for 5 seconds and shifting to the Connecting state.
	Connecting	Contactor closure is executed by performing a pre-charge to protect the BMU contactor and the inverter, an action that is carried out automatically in this state. Once the pre-charging process is completed, the system will shift to the Run state. This process can take several seconds depending on the inverter.
	Run	Once in the Run state, the BMU contactor will be closed and therefore current will be able to flow through the string. (*)
	Shutdown	The Battery System should preferably be switched off from the Ready state. To shift to this Ready state, press the start/stop button for 5 seconds. From this state you can definitively turn off the BMU by disarming the rear circuit breaker (CB) (down position).

(*) If the BMU cannot reach this state, see chapter 8 Troubleshooting.

4.1.2 States of protection

The system also has three protection levels: **Caution**, **Warning** and **Alarm**.

Table 4-2. States of protection.

LED button	State	Description
	Caution	The first protection level is Caution . In this state, the Master limits the corresponding current setpoint to 0 (Charge and/or Discharge) depending on the event. (*)
	Warning	If the Battery System exceeds any Warning level, the BMU of the corresponding string will shift to the Ready state of operation and the contactor will open to protect the string.(**)
	Alarm	Finally, at the Alarm level, the BMU of the corresponding string shifts to the alarm state and the affected BMU will need to be reset manually. Check the cause of entry into this alarm state with the help of the EViewer web app.



(*) If the event conditions are restored, the BMU will perform up to 6 automatic resets for 1 hour in case of **Caution**. If the problem persists, the BMU will shift to the alarm state.

(**) If the event conditions are restored, the BMU will perform up to 3 automatic resets for 1 hour in case of **Warning**. If the problem persists, the BMU will shift to the alarm state.

4.1.3 Operating modes

In addition to the different states, the Battery System has different operating modes that are indicated with the mode LED (blue LED).

Table 4-3. Operating modes.

Mode LED	Operating modes	Description
	Start-up	During start-up, before actually entering the Start-up state, the blue LED indicates that the system is starting up.
	Disabled	If the BMU has not been enabled by the Master, the blue LED will remain on
	Enabled	If the BMU is in Ready state, the mode LED will be turned off while it is enabled

4.2 EQUALISATION

Each of the Modules that make up the Battery System is equipped with a passive equalisation system with the objective of balancing the state of capacity of the cells of each Module.

The equalisation process is controlled by the MCS of the Battery System, which is responsible for starting the process when there is an imbalance between Module cells and also for stopping the process when the imbalance has been mitigated.

5 SYSTEM CONFIGURATION AND START-UP

NOTICE

The installation work has been completed in accordance with the Installation Manual.

5.1 EVIEWER CONNECTION

The Battery System has a web app called EViewer that helps the user and/or installer to configure, monitor and update the equipment. This app runs on any web browser and therefore can be used with any device that has a browser installed, such as a smartphone, laptop or tablet.

To run this web app, the first step is to turn on the Battery System to power the Master unit and achieve connectivity.

5.2 POWERING THE SYSTEM

The steps to follow to power the master unit and achieve connectivity are described below.

INFORMATION

Check the configuration of the Master unit, see Point 6 of the Installation Manual. Configuration of the MASTER MCS unit.

INFORMATION

Check the Battery System's power and communications connections.

INFORMATION

The assignment of the parallel IDs is done in order of response and may not coincide with the order in which the BMUs are installed. If you want the assignment to correlate with the installation, they must be switched on in the desired order with a waiting time of at least 5 seconds between them.

NOTICE

Do not connect the Battery System to the inverter until configuration is completed.

Power all the Battery System's BMUs.

- a) Enable (up position) the rear circuit breaker (CB) on all the BMUs.

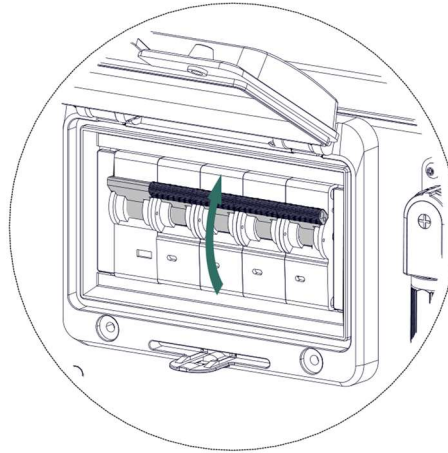
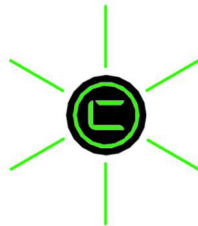

Figure 5-1. Enable the CBs.

- b) Check the LED (slow flashing green) of all the front buttons comes on.



i NOTICE

DO NOT PRESS the front buttons until the system configuration is complete.

3. Using the EViewer platform, connect the system via Wi-Fi or an Ethernet network:

a) Connection via Ethernet cable. (Recommended for laptops)

- Connect an Ethernet cable between the laptop and the ETHERNET port on the Master unit. A Cat5e or higher parallel network cable is recommended.

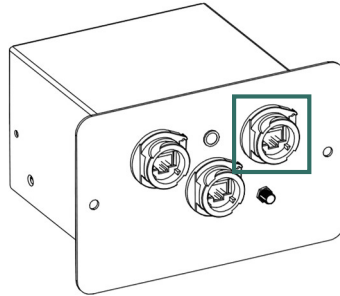

Figure 5-2. Rear of Master unit.

- Configure the IP of the device connected to the MCS to adjust the IP range to the 192.168.55.XXX network (when in doubt, see Annex 5 IP configuration of PC devices).
- Open a web browser on the device and enter the following IP address: <http://192.168.55.180>.

b) Wi-Fi connection. (Recommended for mobile devices)

- Open the Wi-Fi network configurator on the terminal.
- Find the Wi-Fi network called "MCS_XXXXXX" (Where XXXXX corresponds to the serial number of the MCS) and connect using the following password: **Cegasa24**.
- Open a web browser on the device and enter the following IP address: <http://10.0.0.1>

i INFORMATION

If you are using a mobile device, disconnecting the mobile data connection is recommended.

Wi-Fi connection is only available for mobile devices that use the Android operating system.

i INFORMATION

From this point, continue with the system configuration as explained in **Annex A4 system configuration with the EViewer web app EViewer™**.

In case of connection problems, see Chapter 8, Troubleshooting.

6 SYSTEM OPERATION

Once the Battery System is powered, configured and connected to an inverter, users can charge or discharge the system through the inverter.

INFORMATION

Fully charging the system at the start to calibrate the system's SoC value is recommended.

6.1 SYSTEM START-UP

Once the system has been configured on the EViewer platform (as mentioned in the point above), the system will restart to begin to operate with the final configuration. After this restart process (which may take several seconds depending on the number of BMUs and Modules in the system), the blue BMU LED will turn off and the BMU buttons will be lit in the **Ready** state (slowly flashing green) waiting to be initiated.

To start the Battery System, press the front start/stop button of the BMU for 5 seconds (or one of the BMUs if there are several). This starts the contactor closing process for each of the BMUs, always activating the pre-charging process. In this process the system passes through the **Connecting** state (green LED flashing quickly).

Once the pre-charging process is completed, the system enters **Run** state and the strings can receive or deliver current from the inverter if it demands it.

In this **Run** state the LED of the button for all the BMUs will remain in a **fixed green state**.

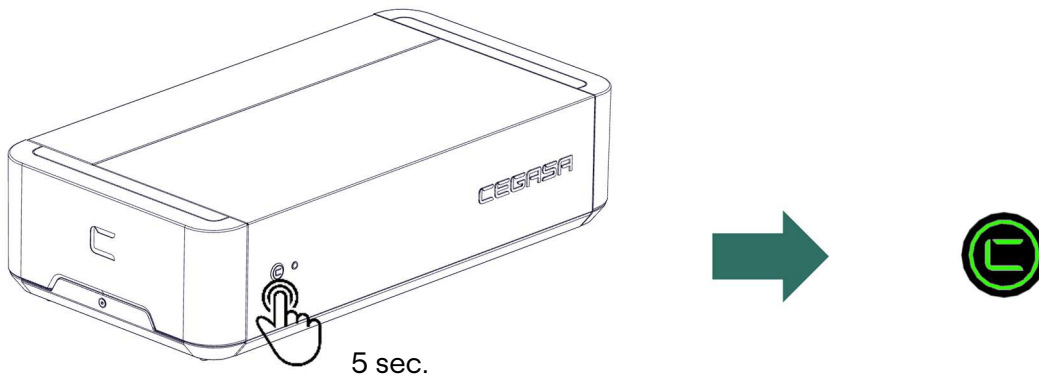

Figure 6-1. System start-up.

Customers can use the EViewer platform to check if the Battery System is connected and each of the strings is being charged/discharged correctly. If any of the BMUs does not reach this state, see chapter 8, Troubleshooting.

6.2 SYSTEM SHUTDOWN

To shut down the Battery System, users must first ensure that no charging or discharging current is circulating through the strings. This can be checked using the EViewer platform, viewing the current passing through the system and its state.

Once the circulating current has stopped, press the start/stop button (5 seconds) on any of the BMUs until all the contactors open. This will cause each of the BMUs comprising the system to go from the **Run** state to the **Ready**.

In this **Run** state the LED on the button of all the BMUs will remain in a **slow flashing green state**.

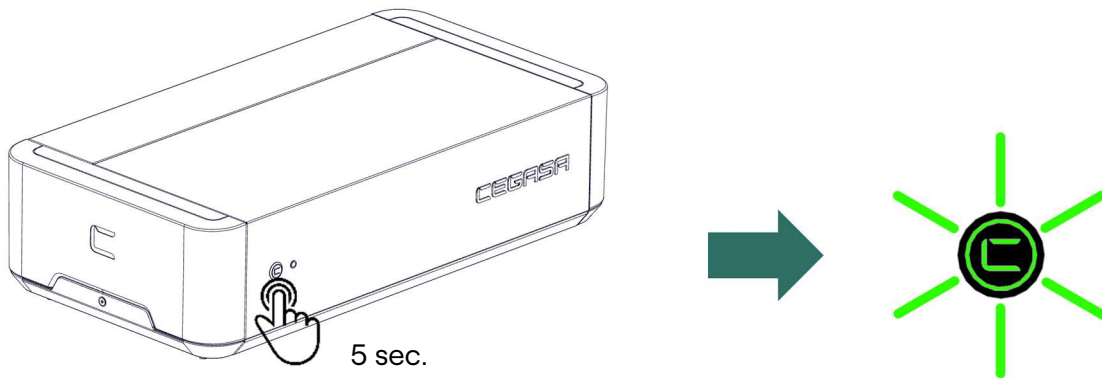

Figure 6-2. System shutdown.

Once in this state, the Battery System can be turned off by disarming the rear circuit breaker (CB) (down position) of each of the BMUs.

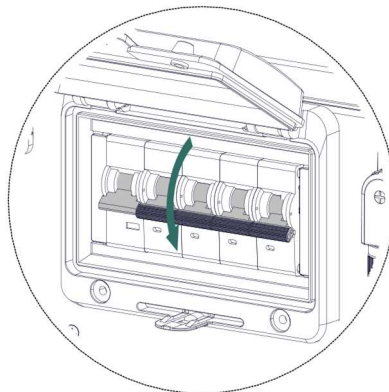

Figure 6-3. Disarm the CBs.

i NOTICE

Remember to disarm the rear circuit breakers (CB) (down position) of all the BMUs if the Battery System is not going to receive any charge for a period of time longer than two weeks, since the internal consumption of the electronics could consume the energy of the Battery System.

6.3 RECOMMENDATIONS FOR USE (CHARGING AND DISCHARGING)

The Master adjusts the voltage and current setpoints depending on the working point and the state of each of the strings.

Table 6-1. Recommendations for use.

Working point	Recommendations for use
Charging	The Battery System must be charged respecting the limits specified in the technical information.
	The system's maximum rated charging current is 63 A. The Master will reduce the current limit by regulation both in the final charge and in case of temperatures exceeding 45°C or temperatures lower than 20°C in the cell.
Discharging	As with charging, the discharge current limit for each BMU is 63 A. The Master will gradually reduce this limit in the event of temperatures above 50°C or below 10°C in the cell.
	It must be taken into account that inverters in off-grid systems do not respect the discharge setpoint limits sent by the Master and operations may be affected if the final application is not correctly sized.

If these usage recommendations are not followed, the Master has event recording tools to ensure fulfilment of the warranty. See Annex A1 Warranty document.

To guarantee the cyclability of the Modules, deep discharges to the system (>80%DOD) are not recommended.



INFORMATION

If you require more technical information, please contact CEGASA.

7 TROUBLESHOOTING

If due to any problem the system is in an alarm state, it issues the following notices.

- The LED on the start button emits a solid red light.
- The Master unit sends the alarm to the inverter via communications and it can therefore be viewed on the inverter's monitoring platform.
- It can be viewed using the EViewer web app (see Annex A4 system configuration with the EViewer web app EViewer).
- The event is recorded in the Master's log files.



NOTICE

If you are not able to start the system and check the error, please contact CEGASA after-sales.

Some of the possible failures that may occur in the Battery System are described below.

Table 7-1. List of failures.

Code	Error	Description	Solution
324	Connection error in SCS	Problem in pre-charge or BMU contactor	1. Contact CEGASA after-sales service
-	SCS does not close contactor	One or more strings in parallel do not close the contactor	1. Check that master has detected all parallels 2. Check that the voltage difference between parallels is less than 2 V 3. Contact CEGASA after-sales service
313	Failure in BMS	BMS internal problem	1. Contact CEGASA after-sales service
321	BMS communications error	SCS does not communicate with one or several BMS	1. Check the correct wiring between BMU and Modules 2. Check correct configuration of number of Modules in web app 3. Contact CEGASA after-sales service
441	SCS communications error	Master does not communicate with one or several BMUs	1. Check the wiring between Master and BMU is correct

Code	Error	Description	Solution
			<ol style="list-style-type: none"> Restart all the BMUs Contact CEGASA after-sales service
443	Inverter communication error	Master is not communicating with inverter.	<ol style="list-style-type: none"> Check communications wiring between inverter and Battery System Check pinout in Master is correct Check that the inverter has been configured correctly in the web app Contact CEGASA after-sales service
205	Module overdischarge	One or more Modules have been overdischarged	<ol style="list-style-type: none"> Arm BMU circuit breaker (upper position) Charge the string as soon as possible
-	Button LED off	The BMU is not on or the LED has failed.	<ol style="list-style-type: none"> Check the circuit breaker is armed (in up position) Check the input voltage of the BMU (rear part) is correct. Use a multimeter Contact CEGASA after-sales service

-	Current sensor failure	The Battery System does not measure current.	<ol style="list-style-type: none"> 1. Check current using a current clamp 2. Check contactor closure is correct by measuring the voltage at the BMU output (rear part). Use a multimeter 3. Contact CEGASA after-sales service
<hr/>			
-	Web app does not load	When entering the appropriate IP address in the browser, the web app does not load	<ol style="list-style-type: none"> 1. If the connection is via ETH cable, check IP is configured correctly on PC 2. If the connection is via Wi-Fi and PC, check antivirus does not block connection. Try with ETH cable
<hr/>			
-	Error during update	After the update process, the system is still in the previous version	<ol style="list-style-type: none"> 1. Switch the whole system off and on again and repeat the process 2. Contact CEGASA after-sales service

8 SYSTEM DISASSEMBLY

CAUTION!

The Battery System must be disassembled by qualified personnel.

CAUTION!

Risk of injury due to the weight of the Modules.

Injuries can occur if Modules are lifted incorrectly or dropped during transportation or installation.

- Transport and lift the Modules carefully. Take into account the weight of the Modules.
 - Wear appropriate personal protective equipment for all work on the Battery System.
-

To disassemble the system, please follow the procedure below:

1. Turn off all inverters connected to the system.
2. Turn off all circuit breakers and/or protection elements between the inverter and the Battery System in the PDC cabinet.
3. Turn off each of the circuit breakers (CB) located on the rear of the BMU.

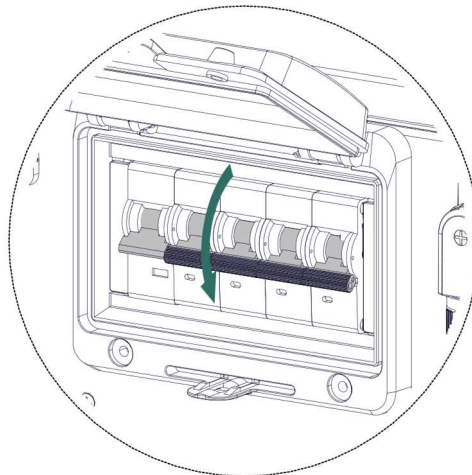

Figure 8-1. Disarm the CBs.

4. Disconnect the communications cables between the inverter and the Battery System (Master).
5. In the case of a system with several BMUs, disconnect the communication cables between them.

6. Disconnect the positive and negative cables on the rear of each BMU.
7. Disconnect the power cables from each string.
8. Disconnect the communications cables from each string.
9. Loosen the screws on the brackets between the BMU and the wall. Then remove the wall mounting plates.
10. Loosen the screws on the brackets between the second tower and the wall. Then remove the wall mounting plates.
11. Loosen the screws and remove the side connection plates between the Modules, between the BMU and the Modules, and between the base and the Modules. Before lifting the Module, make sure you remove the screws and plates on both sides.
12. Loosen the screws on the brackets between the bases and the floor. Then remove the connection plates to the floor and the bases.
13. If the Battery System is to be stored or shipped, package the system. Use the original packaging or suitable packaging for the weight and dimensions of the system.
14. Dispose of or recycle the Battery System according to locally applicable disposal regulations.

9 DISPOSAL SYSTEM

- The Battery System can only be disposed of in accordance with current local regulations on used batteries. If the Battery System is damaged, contact the manufacturer to receive appropriate instructions.
- You must contact the installer or distributor before disposing of it.



Do not dispose of the Battery System with household waste under any circumstances.

- Ensure that the Battery System is not exposed to moisture or direct sunlight once uninstalled.
- Used Battery Systems may contain harmful substances that can harm the environment or health if not stored or disposed of properly.
- Battery Systems contain important raw materials such as iron, zinc, manganese, copper, cobalt and nickel, which can be recycled.

10 TRANSPORT AND STORAGE REQUIREMENTS AND RECOMMENDATIONS

Battery Systems contain hazardous substances categorised as class 9 by the ADR 2013 document identified by number UN3481.

10.1 SHIPMENT

- Ship the Modules in packaging group 1, with approved boxes. Recommendation: do not discard the original shipping boxes.
- Transport with ADR authorisation to move Battery Systems.
- Smoking is prohibited in the vehicle during journeys and also in the vicinity during loading and unloading.
- It is prohibited for the carrier or any unqualified third party not associated with the installation to open the outer packaging of the Battery System.

10.2 ENVIRONMENTAL REQUIREMENTS FOR USE

The area where the system is installed must be equipped with an air conditioning system in order to carry out the system charging and discharging process within the recommended operating temperature.

- Operating temperature range for charging: **0°C to 45°C**
- Operating temperature range for discharging: **-10°C to 55°C**
- Recommended operating temperature range: **15°C to 25°C**
- Operating humidity range (HR): **15% to 90%**

The Battery System control has an internal algorithm to modulate the charge and discharge current depending on the SoC and the temperature of the cells.



INFORMATION

Working outside the recommended temperature range may cause the Battery System to enter alarm or temperature protection state (over or under). It can also lead to a reduction in the life of the system, also affecting the terms of the system warranty (see Annex A1 Warranty document).

10.2.1 Storage recommendations:

- Do not expose the Battery System to areas where it is exposed to direct sunlight or rainfall.
- Do not expose to saline and/or highly corrosive environments.
- Recommended storage SoC (30%-70%).
- Recommended storage temperature (15°C to 25°C).
- Recommended storage humidity range (HR): 15% to 90%.
- Do not exceed 6 months of storage without performing a charge/discharge cycle (*).

10.2.2 Deviations:

- Do not store the Battery System below -5°C.
- Do not store the Battery System above 50°C.
- The Battery System can be stored for 6 months between 0°C and 25°C.
- The Battery System can be stored for 3 months between -10°C and 35°C.
- The Battery System can be stored for 1 month between -20°C and 45°C.

(*) Recommended Module charging cycle: **Ask CEGASA.**



INFORMATION

If the above instructions for storing the Battery System are not followed, the life cycle will be reduced drastically (see Annex A1 Warranty document).

11 MAINTENANCE PLAN

11.1 MAINTENANCE PLAN

The Battery System requires low maintenance. However, a system maintenance procedure must be performed to ensure optimal operation.

This procedure provides the guidelines to follow to ensure proper maintenance, maximising performance and prolonging the lifetime of the Battery System. Follow these instructions to keep the system in optimal condition. Not following these instructions may lead to the reduced life of the system, also affecting the terms of the system warranty (see Chapter 1.8 Limitation of warranties and liability).

11.1.1 Training and Safety

Ensure that the personnel responsible for maintaining the Battery System are adequately trained in maintenance and safety procedures. Use suitable personal protective equipment when handling Battery Systems and follow all relevant safety regulations.

11.1.2 Cleaning

It is recommended to periodically clean all the equipment comprising the energy storage Battery System. If the casing is dirty, use a soft dry cloth or a vacuum cleaner to remove dust. Do not use liquids such as solvents, abrasive products or corrosive liquids.

11.1.3 Storage

A system charge/discharge cycle must be carried out depending on the storage conditions (temperature and storage time), see Section 10 Transport and storage requirements and recommendations.

11.1.4 Temperature

In storage, keep the Modules in an environment with an appropriate and stable temperature. Install in a well-ventilated place protected from direct exposure to sunlight and severe weather conditions. See Section 10 Transport and storage requirements and recommendations.

When in use, ensure that all equipment is working within the temperature range specified by CEGASA (see Chapter 10.2 Environmental requirements for use). Otherwise, have the necessary resources available (isolation, air conditioning, etc.).

11.1.5 Regular Visual Inspection

Carry out periodic visual inspections to detect any physical damage to the system. Pay special attention to the terminals and connections.

11.1.6 Voltage control

Regularly check that the Battery System voltage is within the limits specified by CEGASA on the EViewer platform (Annex 4; Config. Web App System).

11.1.7 Full charge

Fully charge the battery system at least once a month to update possible deviations from the SoC calculation algorithm, see Annex A1 Warranty document.

11.1.8 Deep discharges

Avoid discharging the Battery System below an SoC of 10%. Deeper discharges will significantly affect the lifetime. If the Battery System is overdischarged, its protection will be triggered, but it is important to ensure the following:

- Charge the overdischarged Battery System within 7 days if the room temperature is equal to or greater than 25°C, see Annex A1 Warranty document.
- Charge the overdischarged Battery System within 15 days if the room temperature is below 25°C, see Annex A1 Warranty document.

11.1.9 Checking notices and alarms

Regularly check for the absence of any notices and/or alarms on the EViewer platform, (see Section 7 Troubleshooting).

11.1.10 Log and documentation

Keep a detailed log of all maintenance activities performed on the energy storage Battery System, including inspection dates, voltage measurements, cleaning and any other actions taken. Keep these logs up-to-date to make it easier to track the system status.

11.1.11 Updating firmware

Make sure your system is updated with the latest FW version.

INFORMATION

Please contact CEGASA if you require more technical information.

INFORMATION

This maintenance plan must be followed to make the product warranty effective.

11.2 CORRECTIVE MAINTENANCE PLAN

In the event of a breakdown and you need to replace any unit of the Battery System, please contact CEGASA's technical team (SAT) for assistance. Under no circumstances should you manipulate or open any unit; if you do, the equipment warranty will be fully void.

12 SPECIFIC ANNEXES

A1 WARRANTY DOCUMENT

A2 CAN BUS COMMUNICATIONS PROTOCOL

A3 MOD BUS COMMUNICATIONS PROTOCOL

A4 SYSTEM CONFIGURATION WITH THE EVIEWER WEB APP

A5 IP CONFIGURATION OF PC DEVICES

Energy you can trust

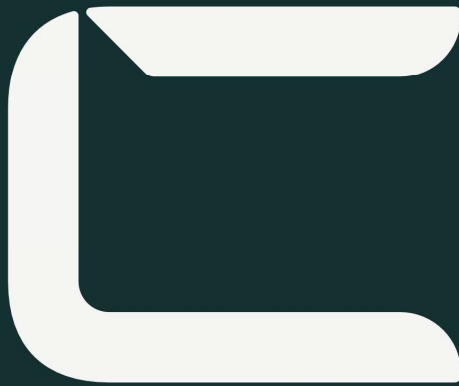

CEGASA

Spain. Production Centre
Cegasa Energía S.L.U.
Parque Tecnológico de Álava, Calle Marie Curie 1
01510 Miñano, Vitoria-Gasteiz (Álava, Spain)

www.cegasa.com
hello@cegasa.com

+34 945 31 37 38