

CEGASA

Energy you can trust



E/Scal HV

Installation Manual

Original manual
Version May 2025

Control of revisions

VERSION	DATE	DESCRIPTION
Jan 2025	27.01.2025	Content update
May 2025	22.05.2025	Content update

Table of Contents

1	<u>Introduction</u>	<u>4</u>
1.1	<u>Purpose of the manual</u>	<u>4</u>
1.2	<u>Confidentiality</u>	<u>4</u>
1.3	<u>Safety during assembly</u>	<u>5</u>
1.3.1	<u>General</u>	<u>5</u>
1.3.2	<u>Mechanical</u>	<u>5</u>
1.3.3	<u>Fire prevention measures</u>	<u>6</u>
1.3.4	<u>Anti-electrolyte measures</u>	<u>6</u>
2	<u>Components</u>	<u>7</u>
2.1	<u>Base (110056)</u>	<u>7</u>
2.2	<u>Portable base (110057)</u>	<u>8</u>
2.3	<u>HV EScal Module (110054)</u>	<u>9</u>
2.4	<u>EScal BMU control unit (110055)</u>	<u>10</u>
2.5	<u>Tower kit (110097)</u>	<u>11</u>
2.6	<u>Master MCS unit (110052)</u>	<u>12</u>
3	<u>Necessary tools</u>	<u>13</u>
4	<u>Installation</u>	<u>14</u>
4.1	<u>Single tower</u>	<u>14</u>
4.2	<u>Two towers</u>	<u>36</u>
5	<u>Connections</u>	<u>69</u>
5.1	<u>Connecting a string</u>	<u>69</u>
5.2	<u>Connecting several strings (up to 4)</u>	<u>72</u>
5.3	<u>Configuration of master MCS communications</u>	<u>73</u>
6	<u>Configuration of the Master MCS unit</u>	<u>74</u>

6.1 MODBUS TCP/IP communication protocol.....74

6.2 CAN bus communication protocol.....74

1 INTRODUCTION

Read this manual carefully to ensure the energy storage Battery System is properly installed. All these operations must be performed by a qualified and authorised technician.

1.1 PURPOSE OF THE MANUAL

This is the complete manual for the installation of the energy storage system made up of the following products.

Table 1-1. Glossary.

TERM	DEFINITION
Module	HV EScal Module.
BMU	EScal BMU control unit.
Master	Master MCS unit.
PDC	PDC distribution and protection cabinets.
Inverter	Hybrid inverter.
Tower	Group of Modules stacked high.
String	Group of Modules connected in series and controlled by an EScal BMU control unit.
Battery System	Energy storage battery system.
EViewer web app	Battery System monitoring platform.
CEGASA Cloud	Cloud platform.

1.2 CONFIDENTIALITY

All the information provided by CEGASA ENERGIA SLU by virtue of this manual and any data or aspects that may become known as a result thereof will be absolutely confidential, and may not be provided to third parties or used for any purpose other than that intended, without the prior and express written authorisation of CEGASA ENERGIA SLU, (hereinafter CEGASA).

1.3 SAFETY DURING ASSEMBLY

The Battery System has been designed and tested in accordance with international safety standards. However, to avoid personal injury and property damage and ensure long-term operation of the Battery System, please read this section carefully and follow all recommended safety measures.

1.3.1 General

- The area around the Battery System must be kept clear and free of combustible materials, petrol and/or other flammable vapours and liquids.
- Any air inlet or outlet in the room must be clear and free of obstacles.
- There must be no signs of deterioration in any component of the Battery System. Contact CEGASA with any questions.
- Do not access the interior of the BMU, or the Modules, or manipulate any internal components.
- Do not use or manipulate the Battery System components if your feet or hands are wet.
- Ensure that the output and input connection cables are not short circuited.
- Ensure that there is no short circuit between positive and negative terminals at any point.
- Follow the specifications proposed by CEGASA for the power and communications cables of the installation.
- Do not use, handle, install or store the Battery System in damp or very humid conditions.

1.3.2 Mechanical

- The floor must be capable of holding the weight of the entire Battery System made up of one or multiple towers. The floor must be in optimal condition.
- Due to the weight of the Modules (>50 kg), they must be installed by two people.
- Do not stack more than 8 Modules per tower. Always stack them on top of their base fixed to the floor and levelled according to the instructions.
- Brace/fix the tower to the wall at a height according to the instructions.

1.3.3 Fire prevention measures

- Ensure there is a carbon dioxide extinguisher nearby.
- Do not use water to extinguish the fire.
- Full protective clothing and self-contained breathing apparatus are required for firefighters to extinguish the fire.

1.3.4 Anti-electrolyte measures

If the Battery System loses electrolyte due to a system malfunction, avoid contact with the leaking liquid or gas.

Electrolyte is corrosive and contact can cause skin irritation and chemical burns. In case of exposure to this substance, proceed as follows:

- Inhalation: Evacuate the contaminated area.
- Contact with eyes: Rinse eyes with cold water for 15 minutes.
- Contact with skin: Carefully wash the affected area with cold water and soap.
- Ingestion: Induce vomiting.

In any of the above cases, seek immediate medical assistance.

2 COMPONENTS

2.1 BASE (110056)

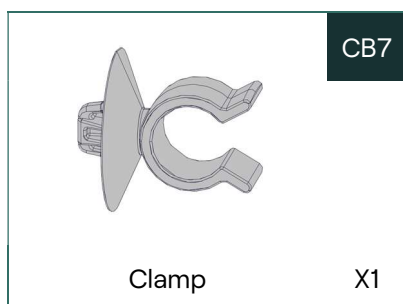
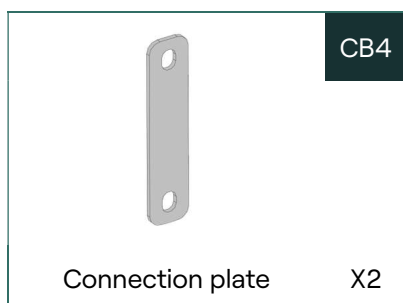
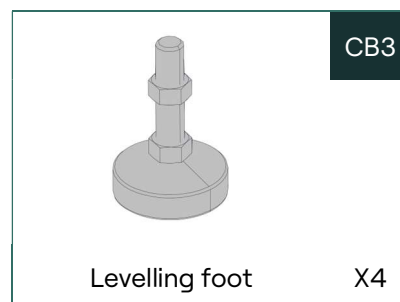
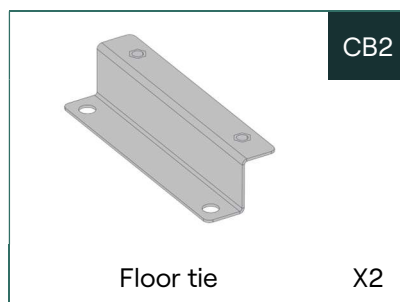
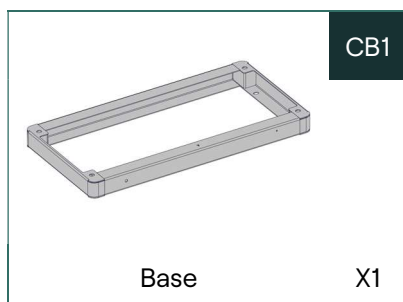

2.2 PORTABLE BASE (110057)

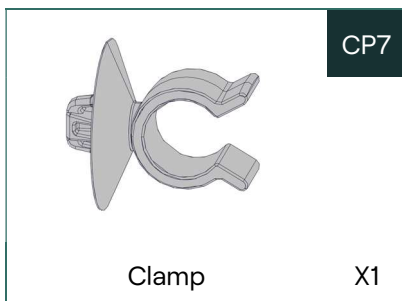
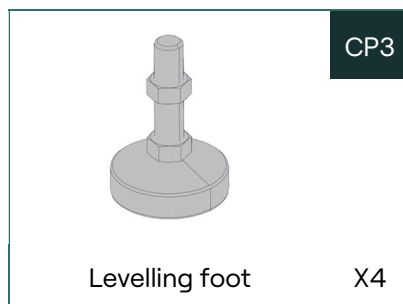
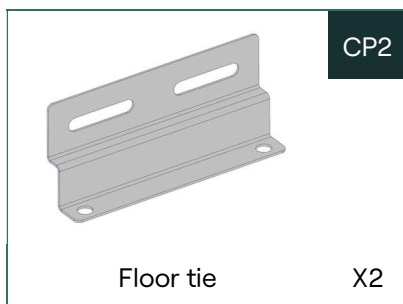
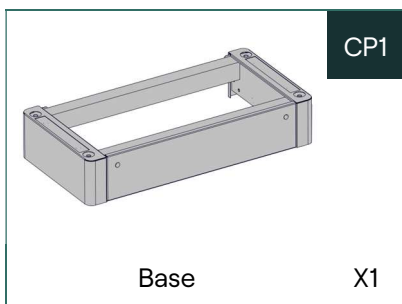

2.3 HV ESCAL MODULE (110054)

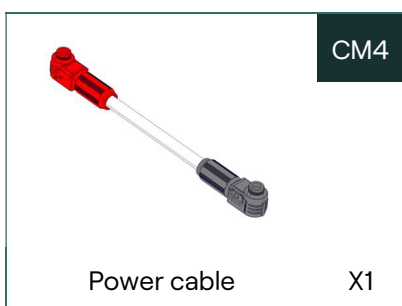
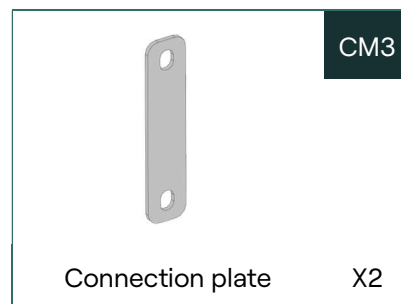
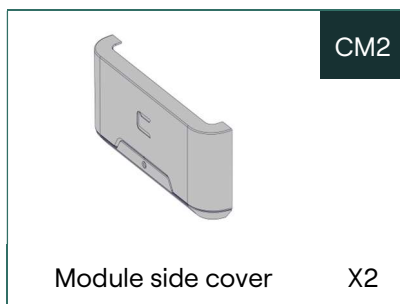
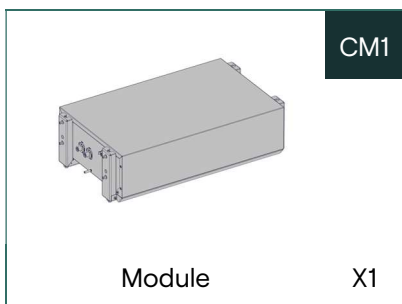

2.4 ESCAL BMU CONTROL UNIT (110055)

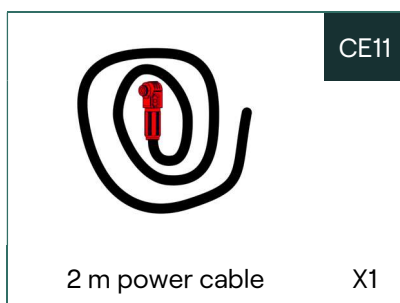
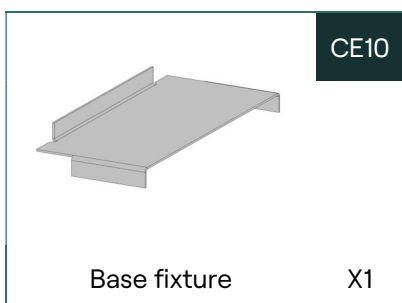
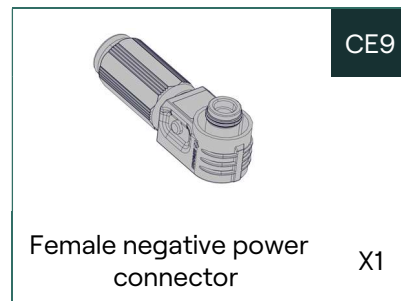
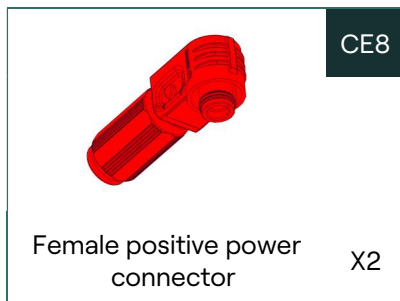
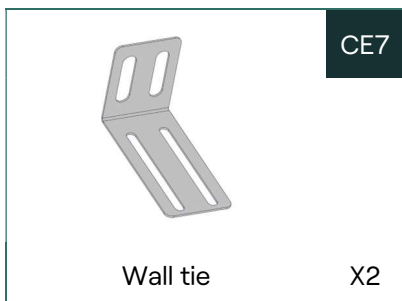
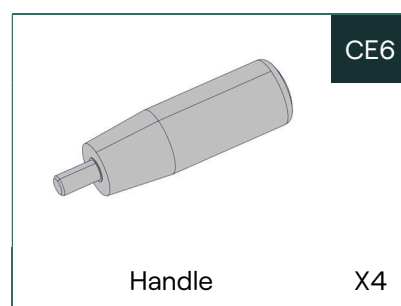
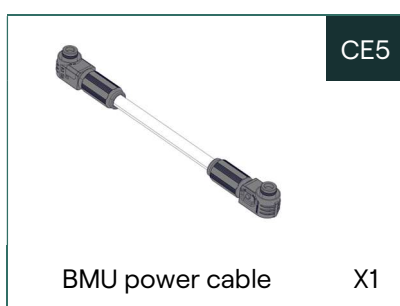
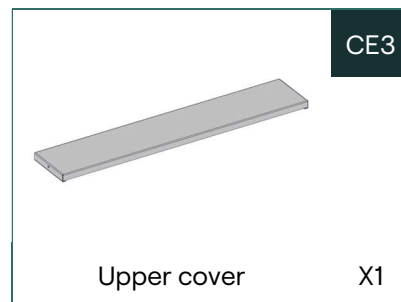
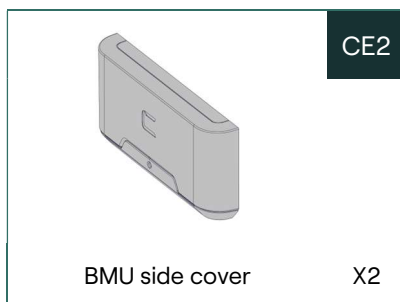
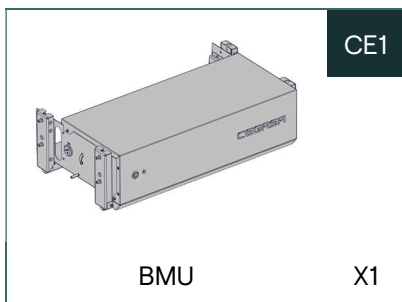

2.5 TOWER KIT (110097)

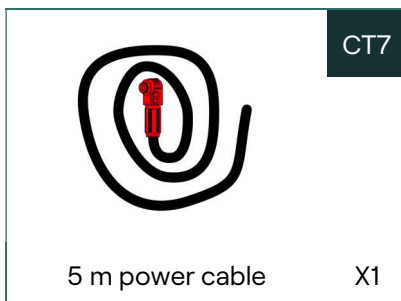
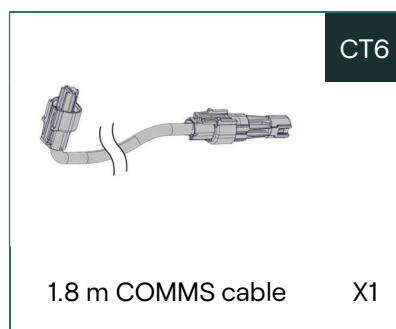
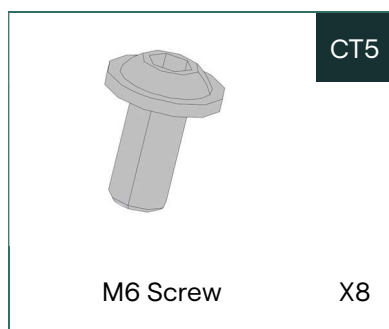
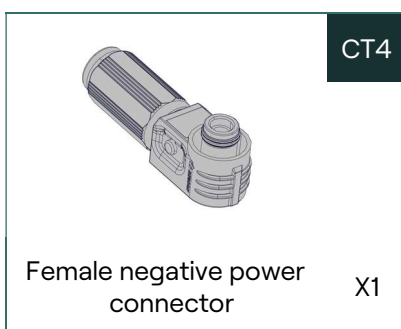
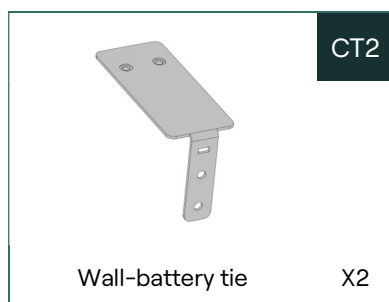
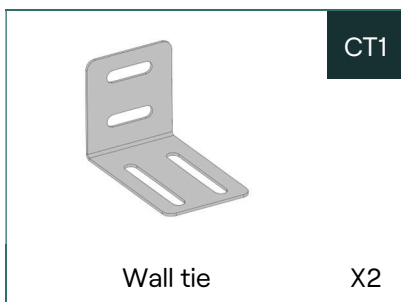

2.6 MASTER MCS UNIT (110052)

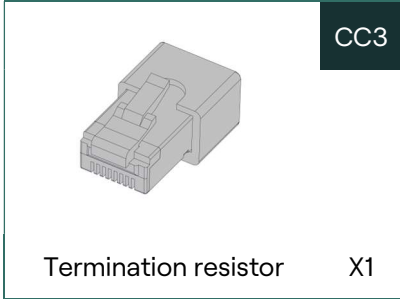
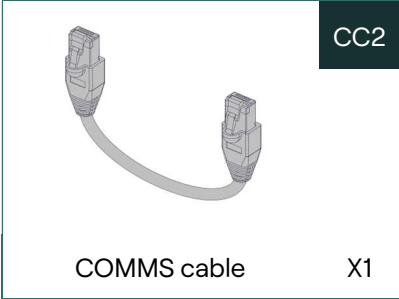
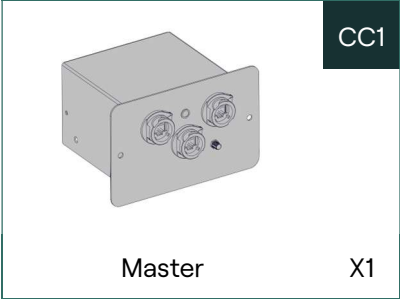

3 NECESSARY TOOLS

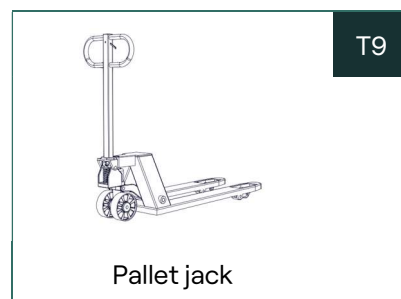
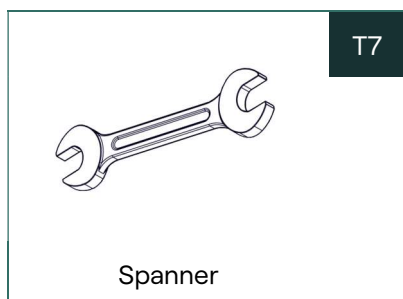
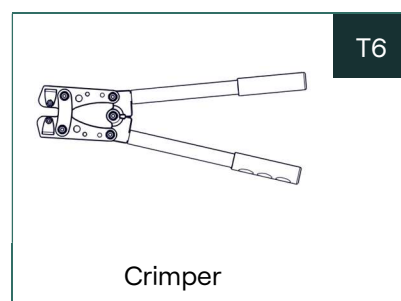
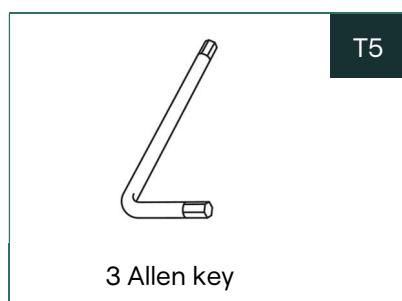
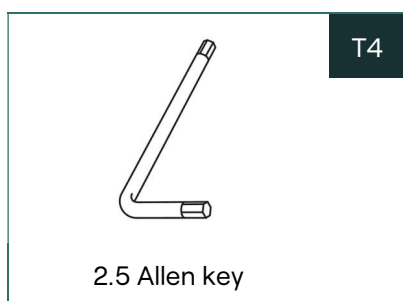

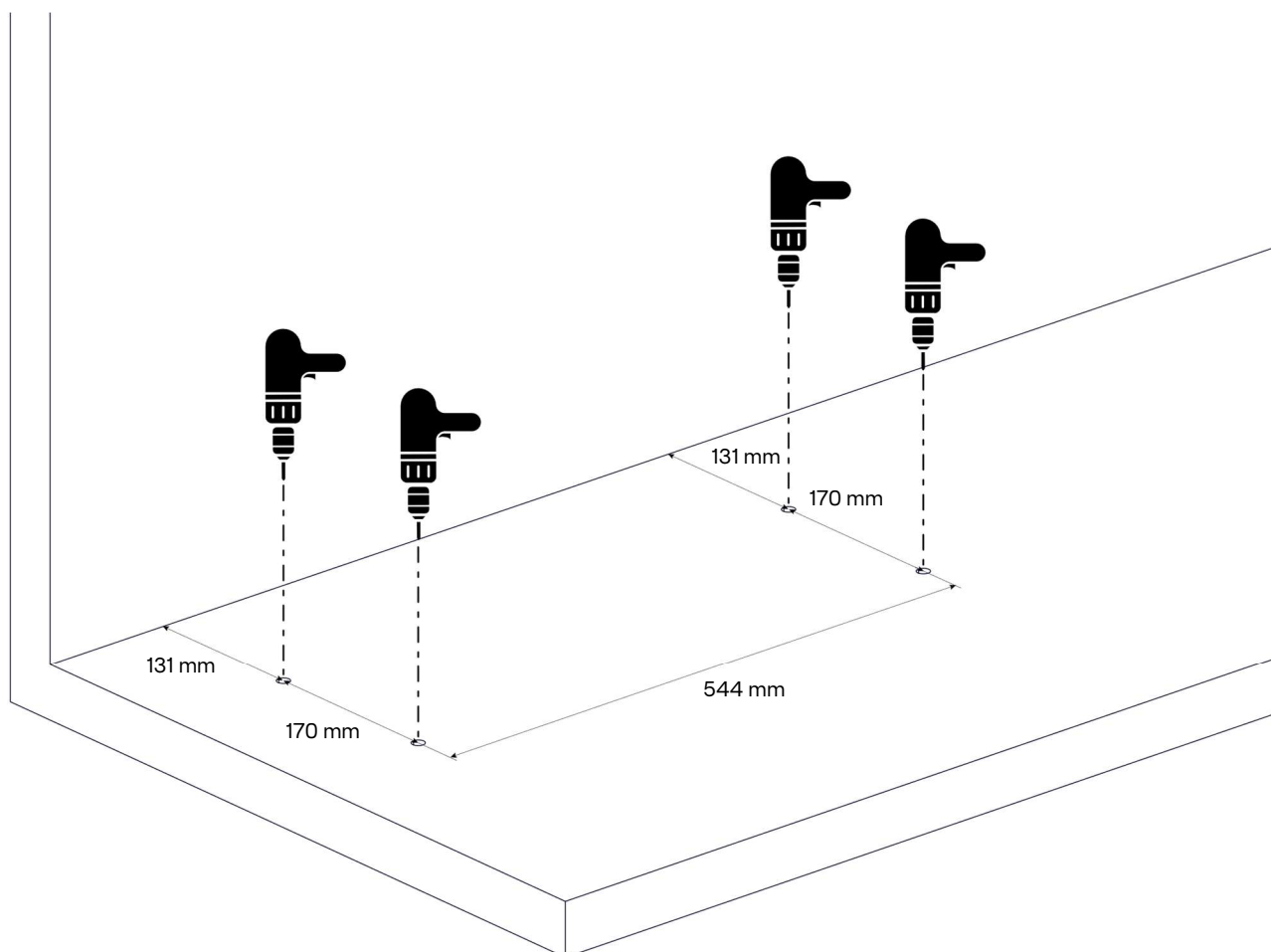
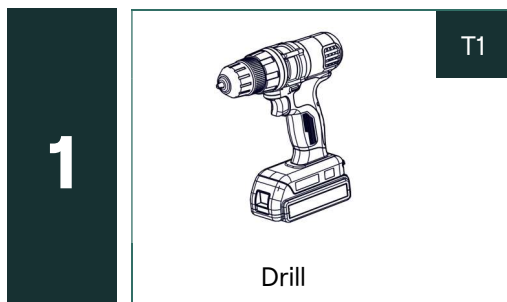

4 INSTALLATION

4.1 SINGLE TOWER

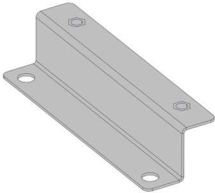

Use of M12 metal expansion bolts is recommended. Not provided by CEGASA.

2	 Floor ties	CB2 X2	 Spanner	T7

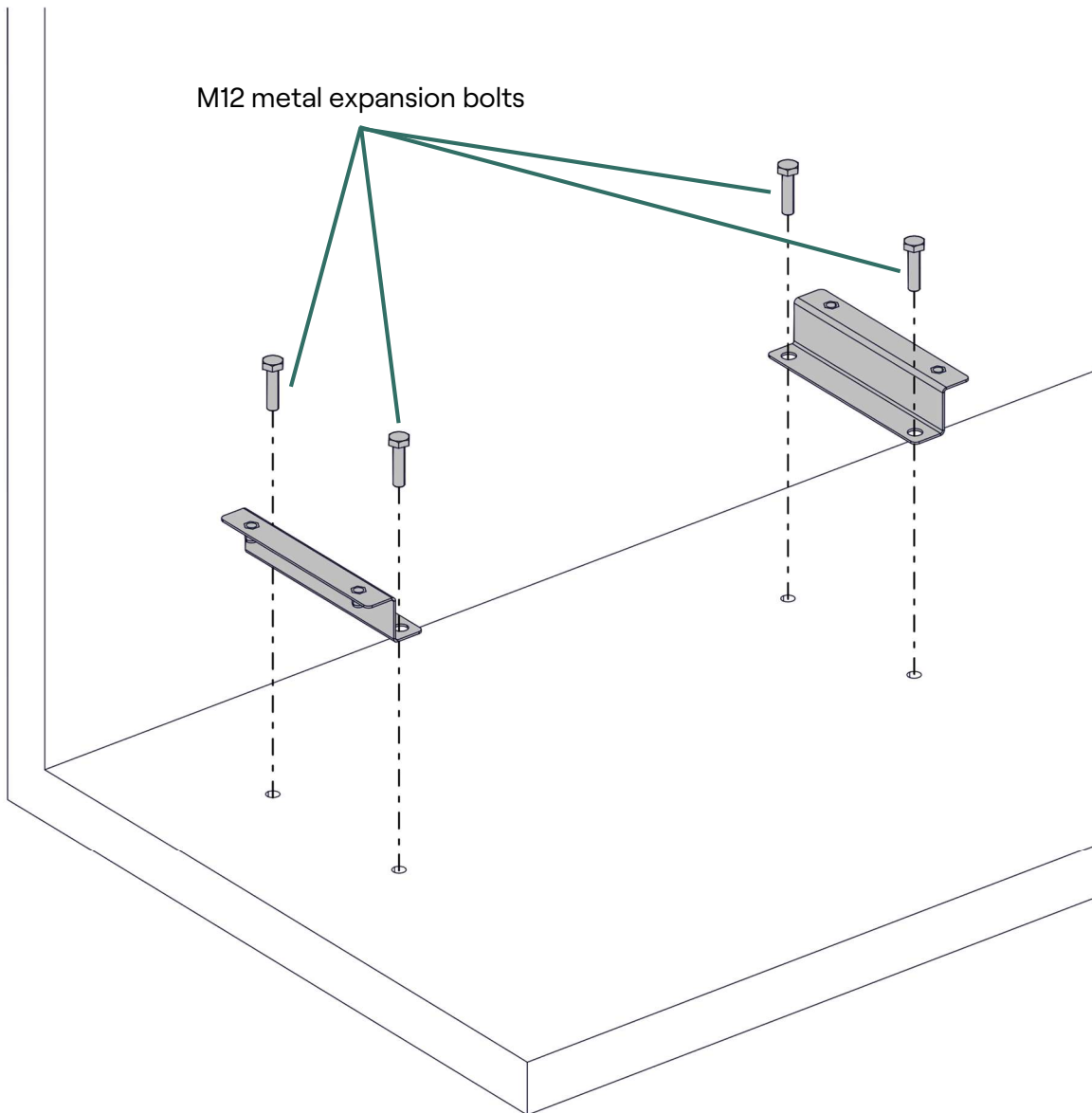

Use of M12 metal expansion bolts is recommended. Not provided by CEGASA.

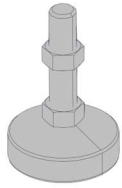
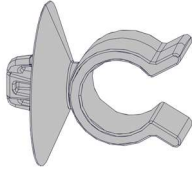
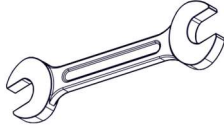
3		CB3
	Levelling foot	X4
		CB7
	Clamp	X1
		T7
	Spanner	

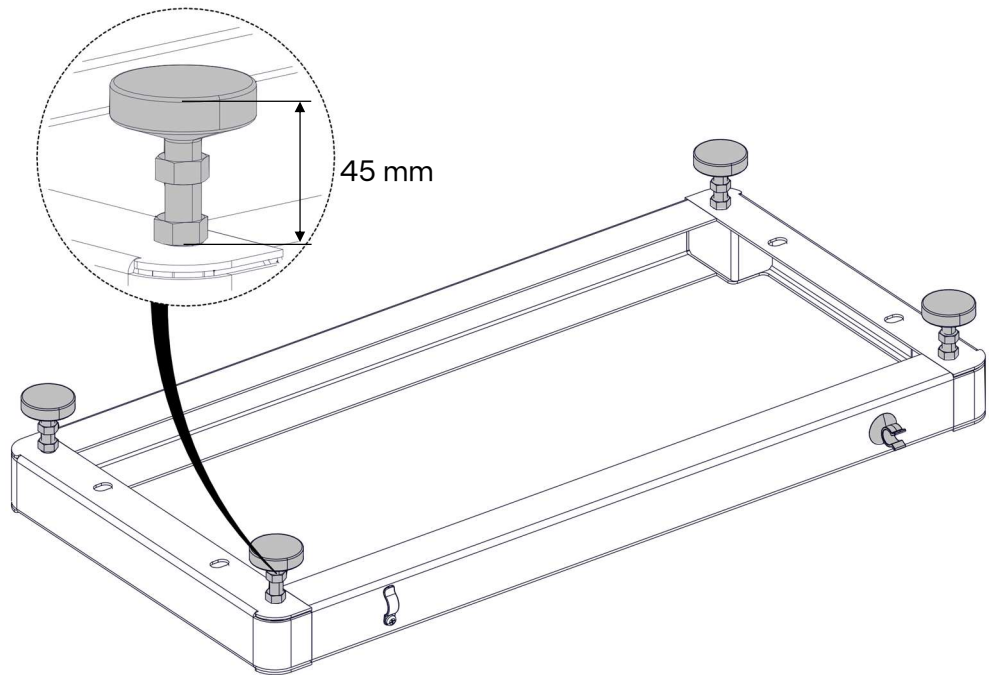
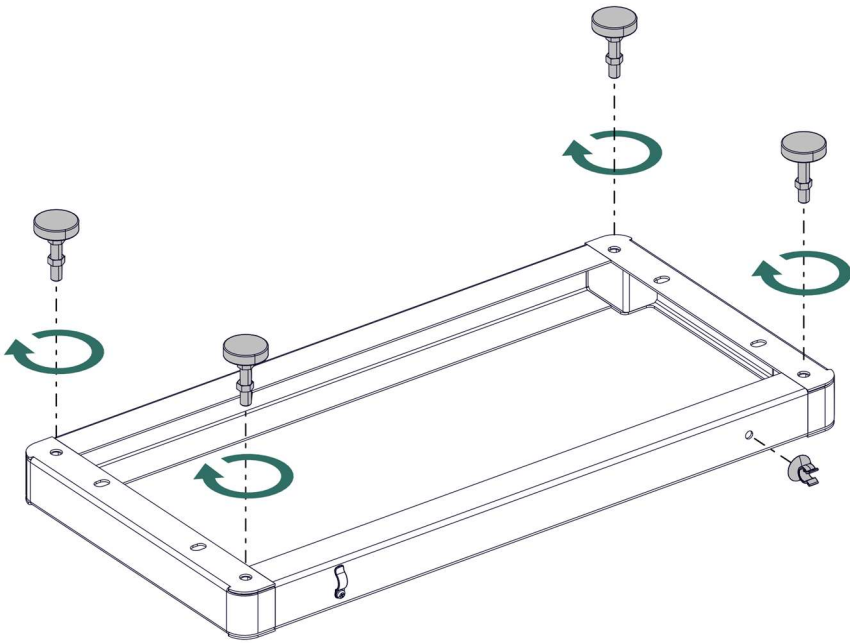

4

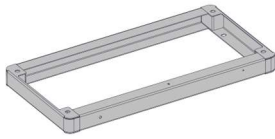

CB1

Base

X1

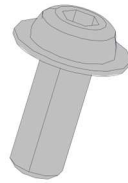

CB5

M8 Screw

X4



T12

Torx T35 screwdriver

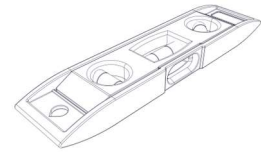

T2

Spirit level

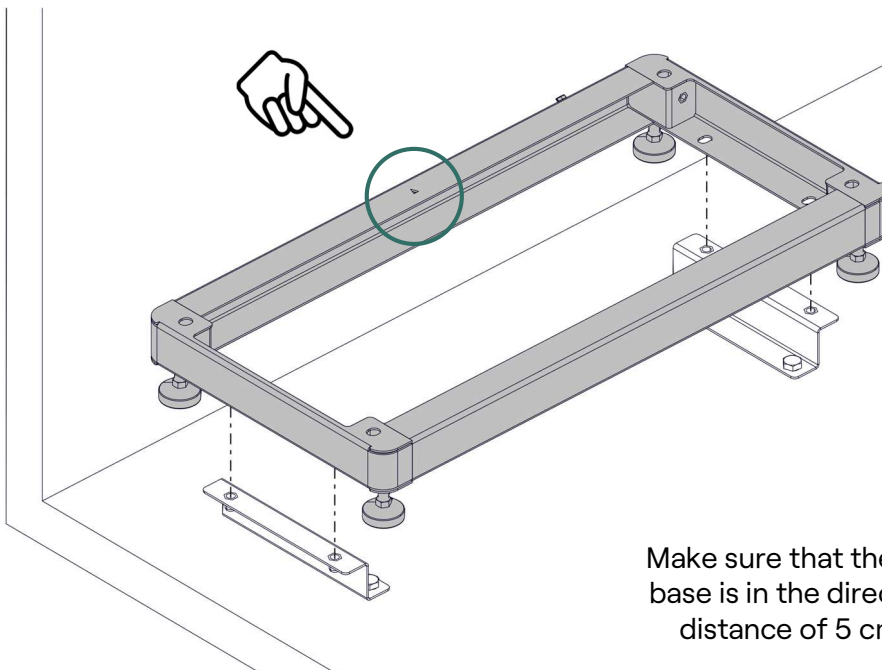

Check the levelling and adjust the feet if necessary.



Make sure that the arrow engraved on the base is in the direction of the wall and at a distance of 5 cm between the base and

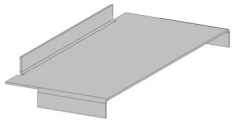
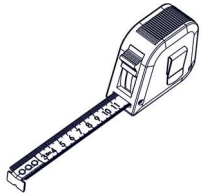
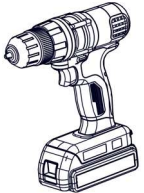

50 mm

5	 Base fixture X1	 Tape measure T3	 Drill T1
----------	--	--	---

 This step is only necessary if the tower has 5 Modules or

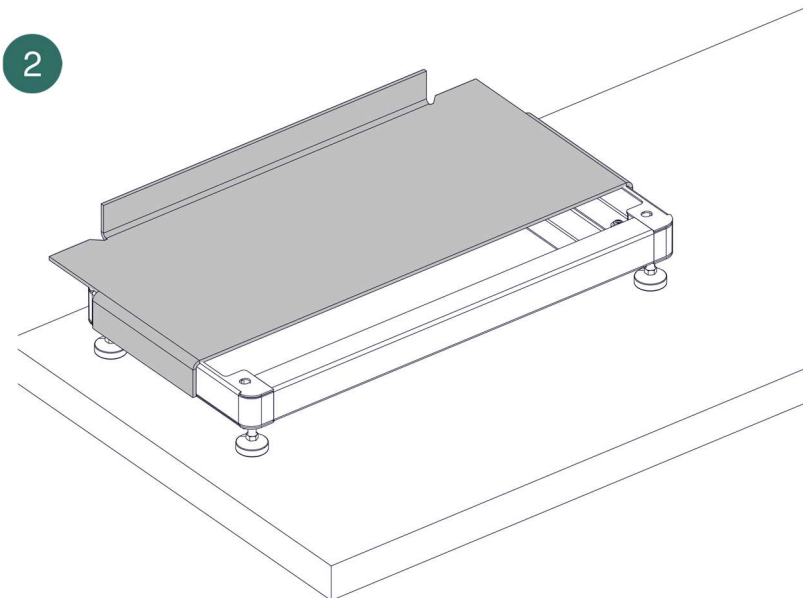
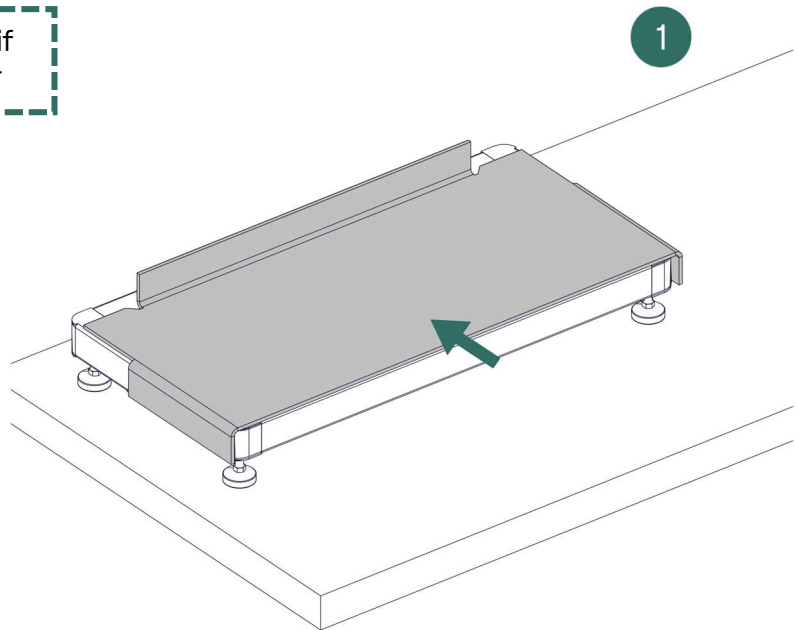

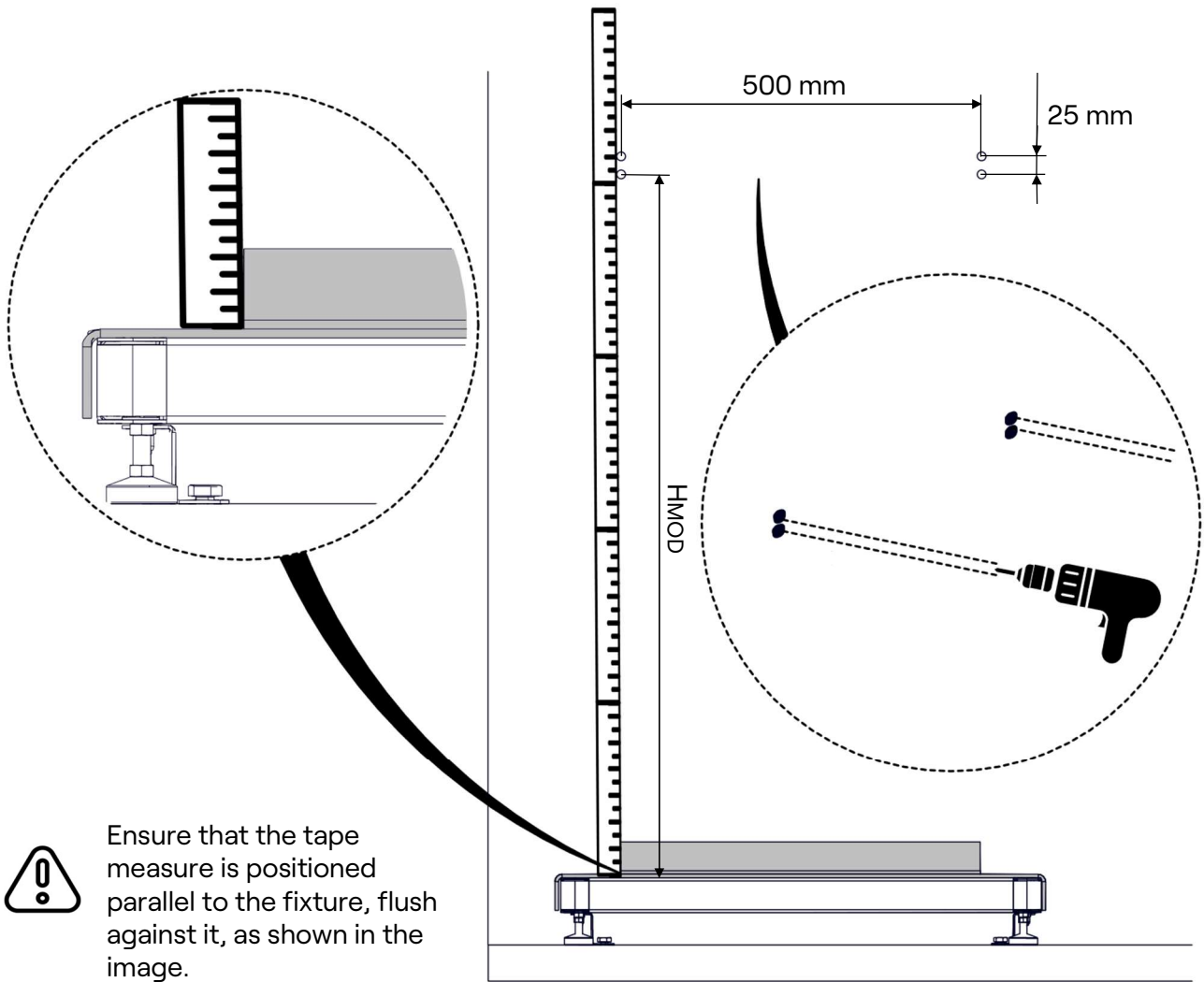

No. MODULES	HMOD
5	977 mm
6	1156 mm
7	1334 mm
8	1512 mm

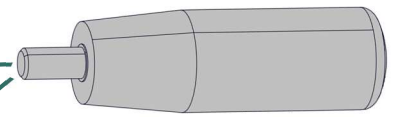
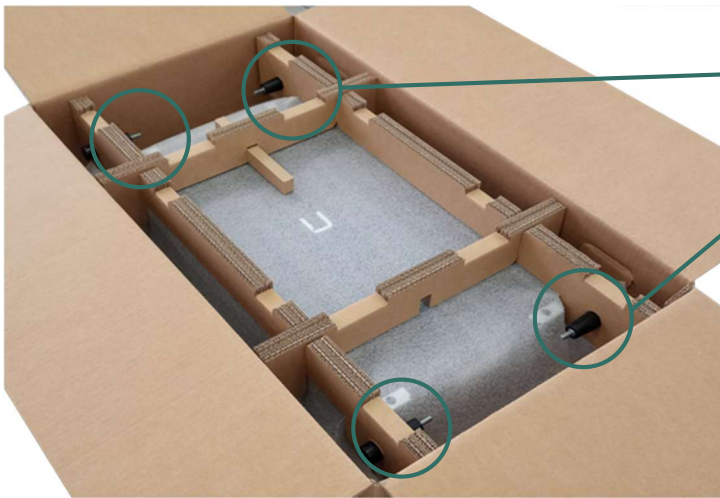
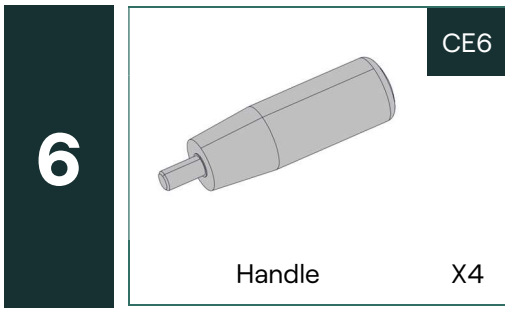

i The handles can be found inside the BMU box.

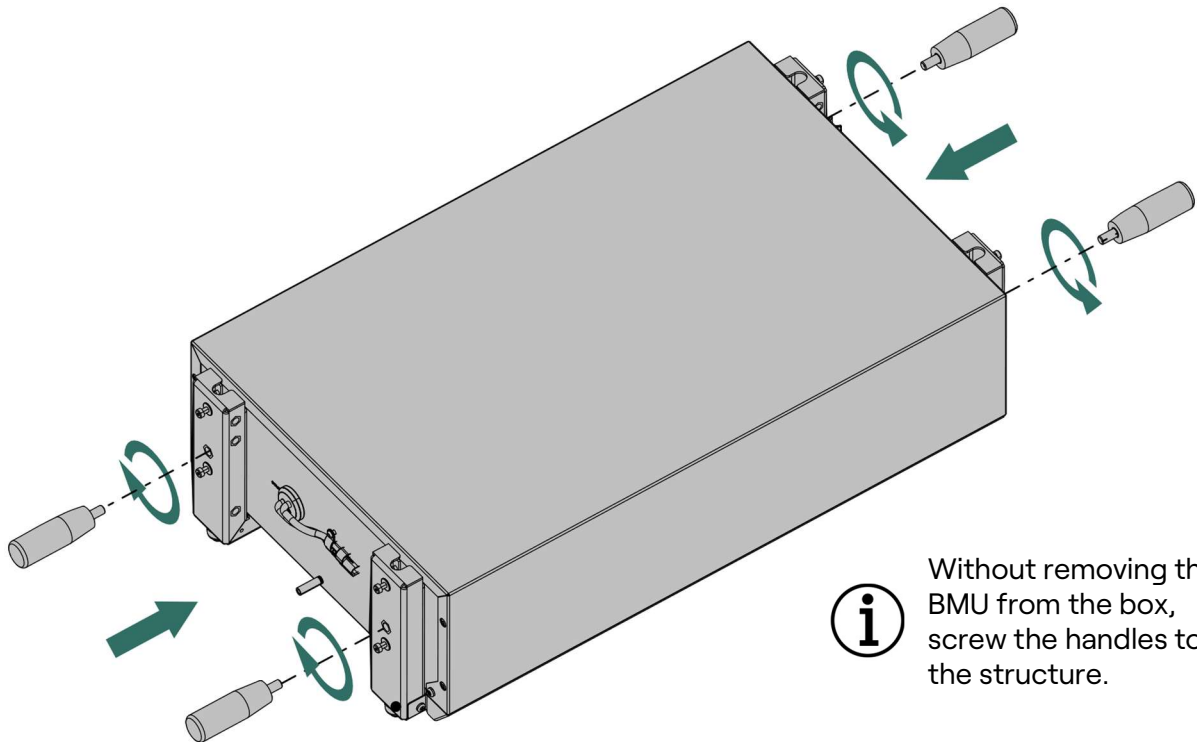

i Without removing the BMU from the box, screw the handles to the structure.

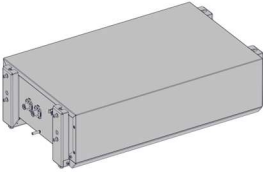
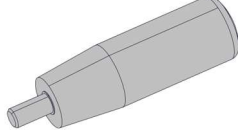
7	 Module X1	 Handle X4
	CM1	CE6

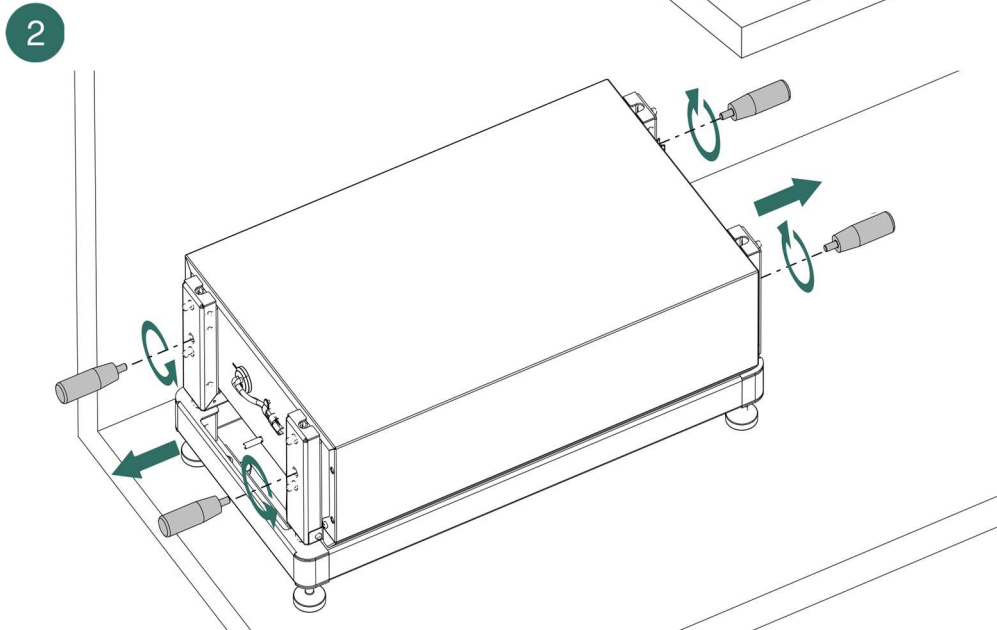
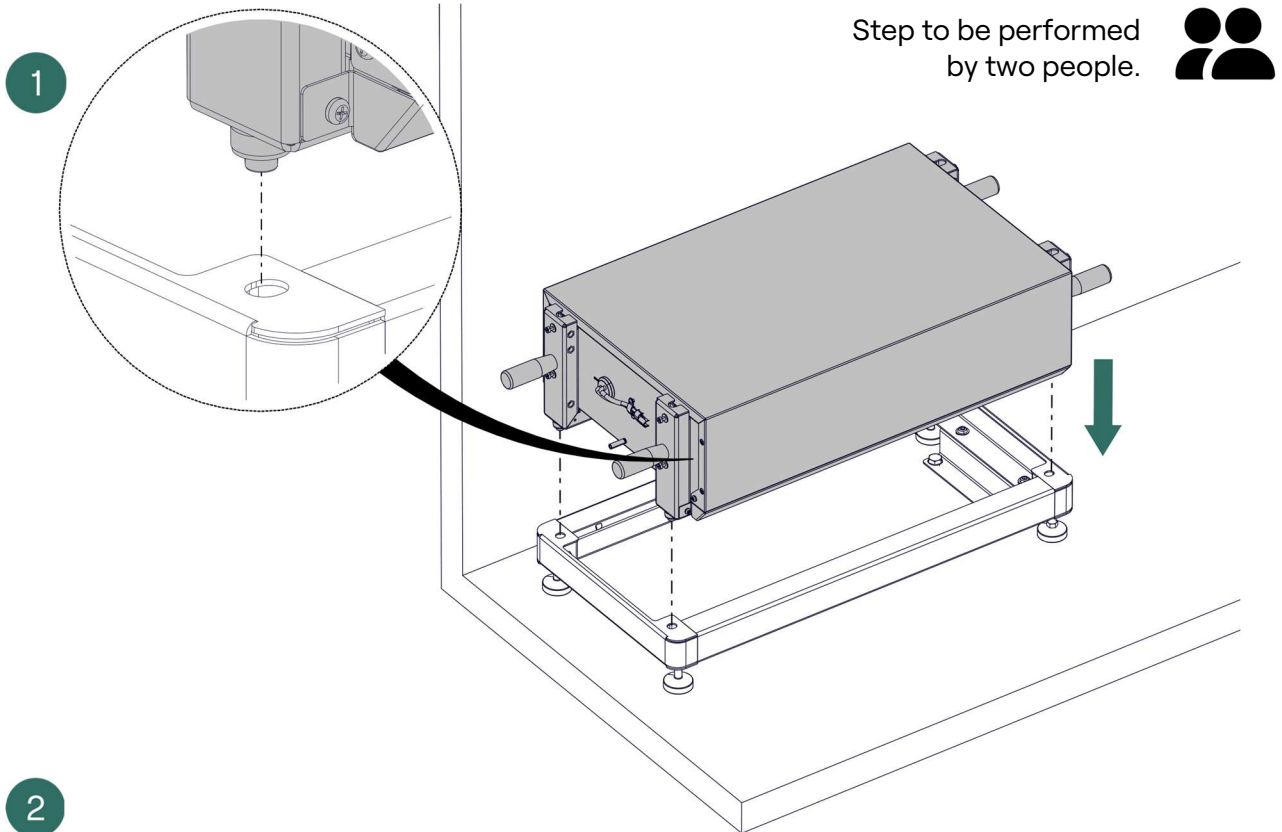

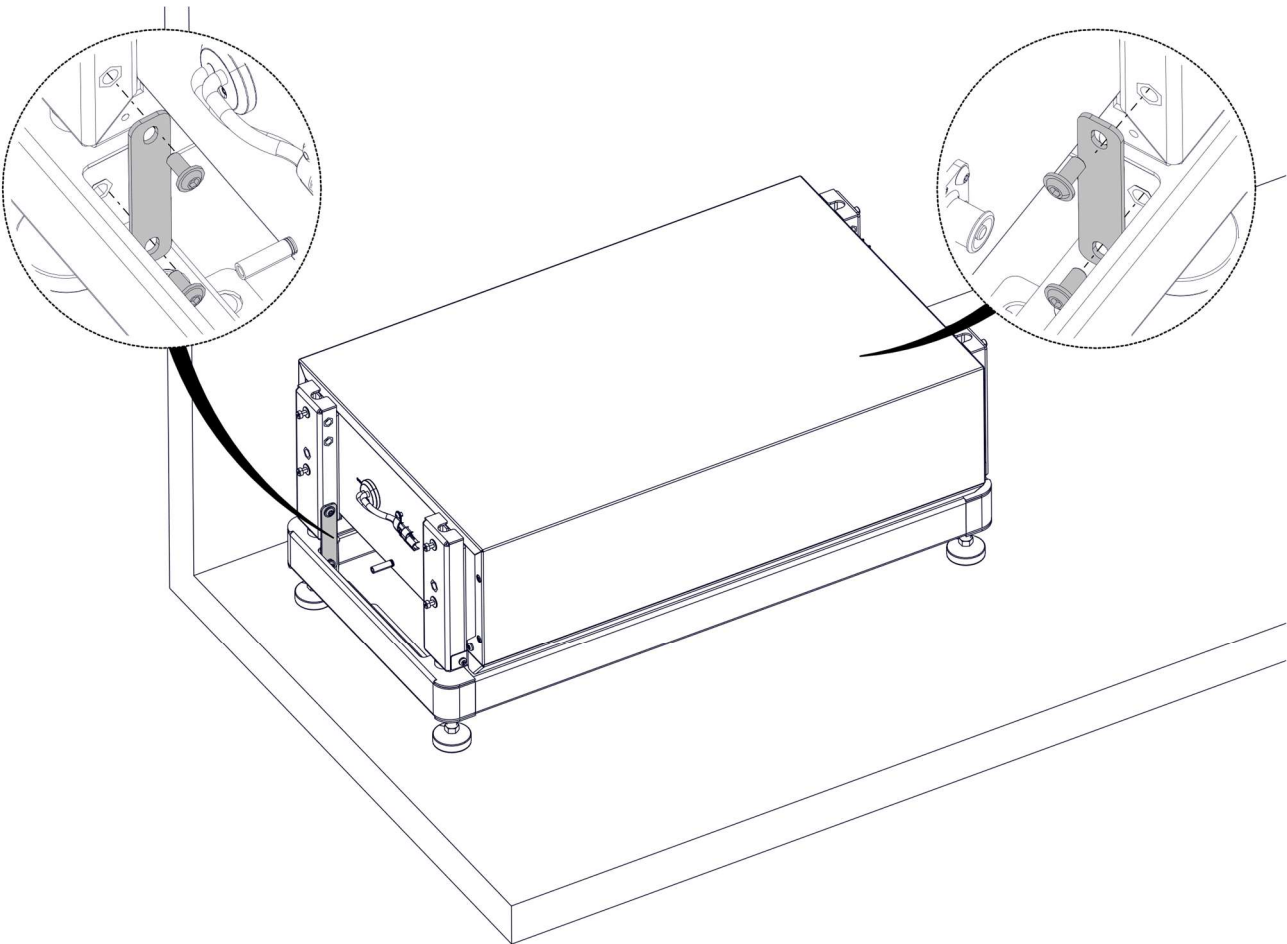

8	 Connection plate X2	CB4	 M6 Screw X4	CB5	 Torx T30 screwdriver	T11
----------	--	-----	--	-----	---	-----

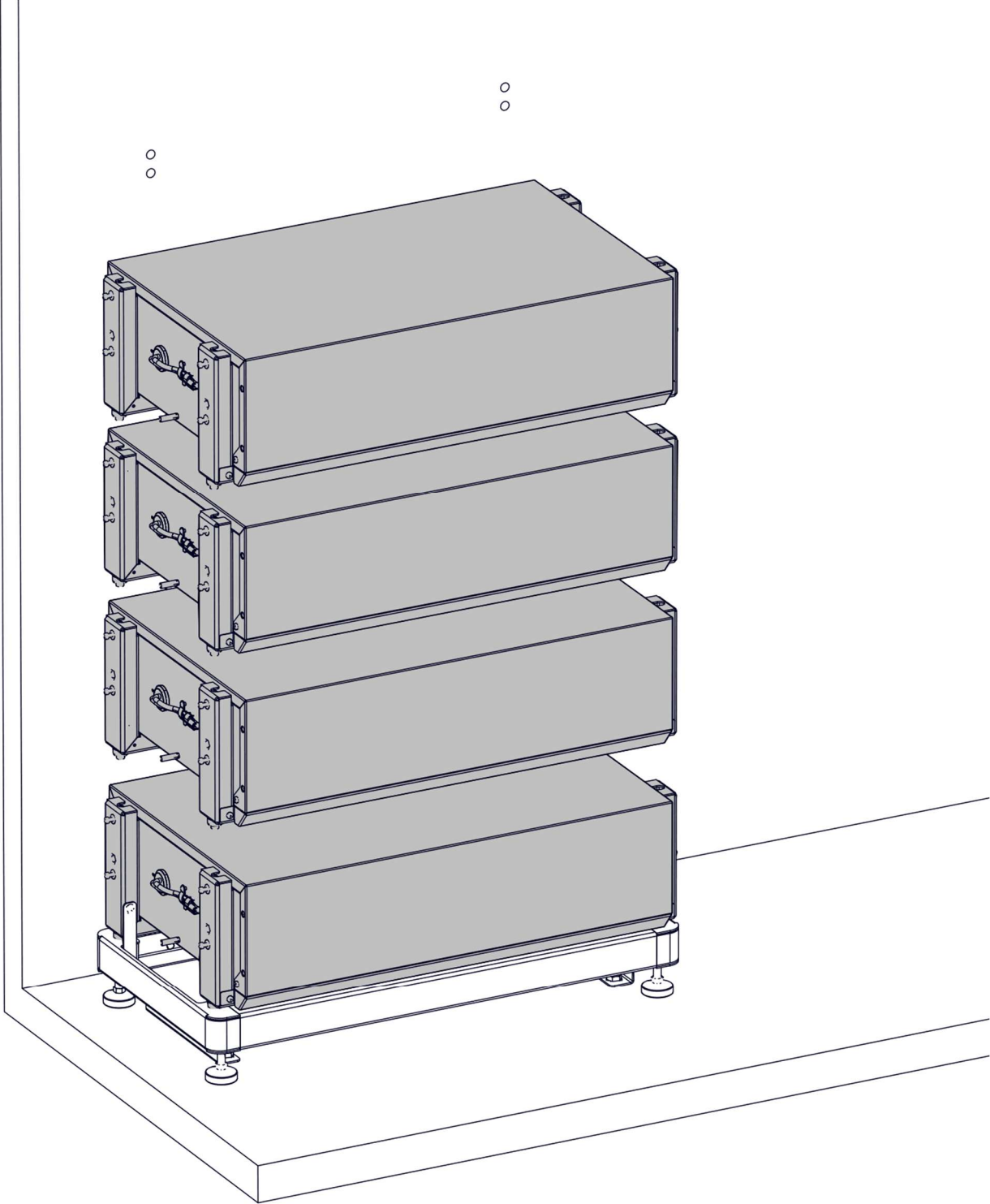

Place the desired number of Modules from 3 to 8.
The installation is the same as in the lower Module.

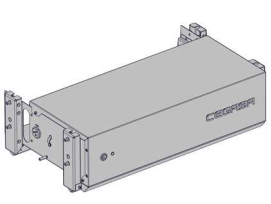
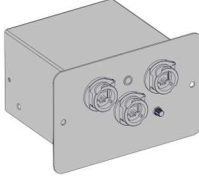

9	 BMU X1	 Master X1	 Torx T20 screwdriver
	CE1	CC1	T10

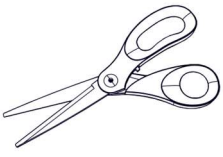
 Scissors	T8
---	----

1

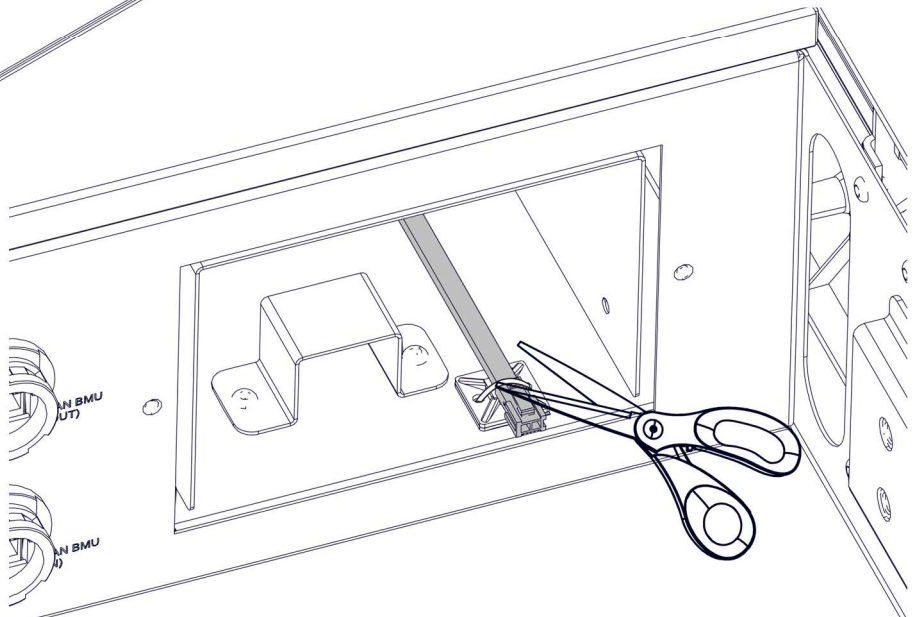
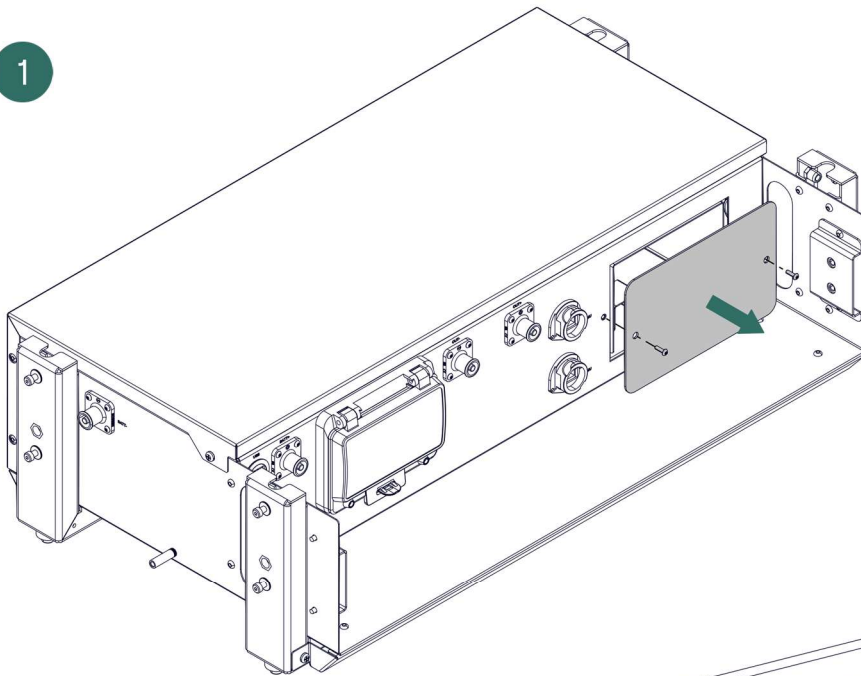

Be sure not to damage the cable when cutting the tie with scissors.





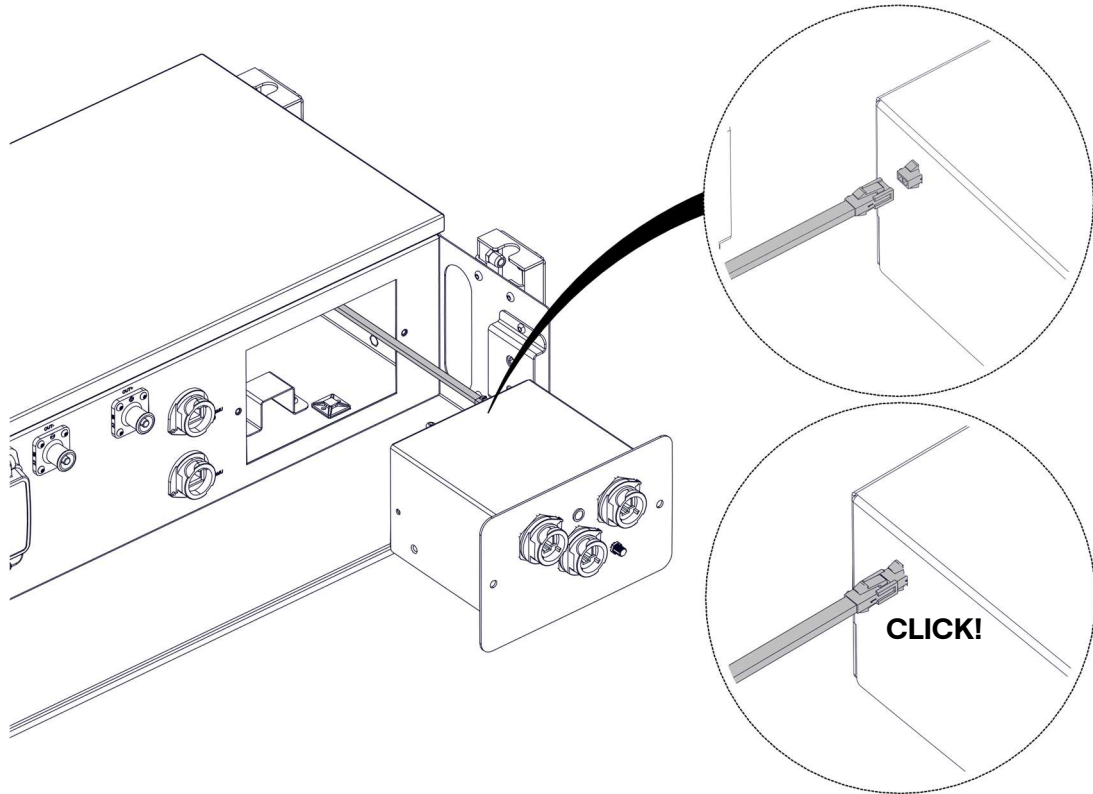

Before installing the Master, check its configuration (see Section 6/page 73).

2

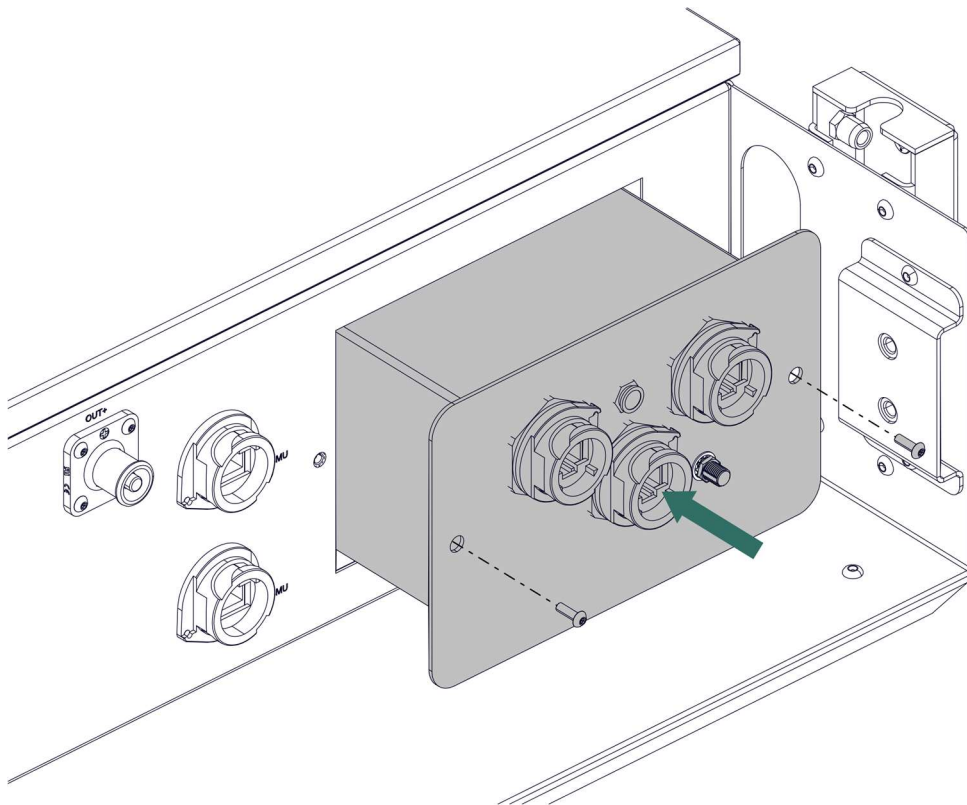

3

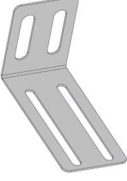

10	 Wall tie X2	 M6 Screw X4	 Torx T30 screwdriver
	CE7	CE4	T11

 This step is only necessary if the tower has 5 Modules or

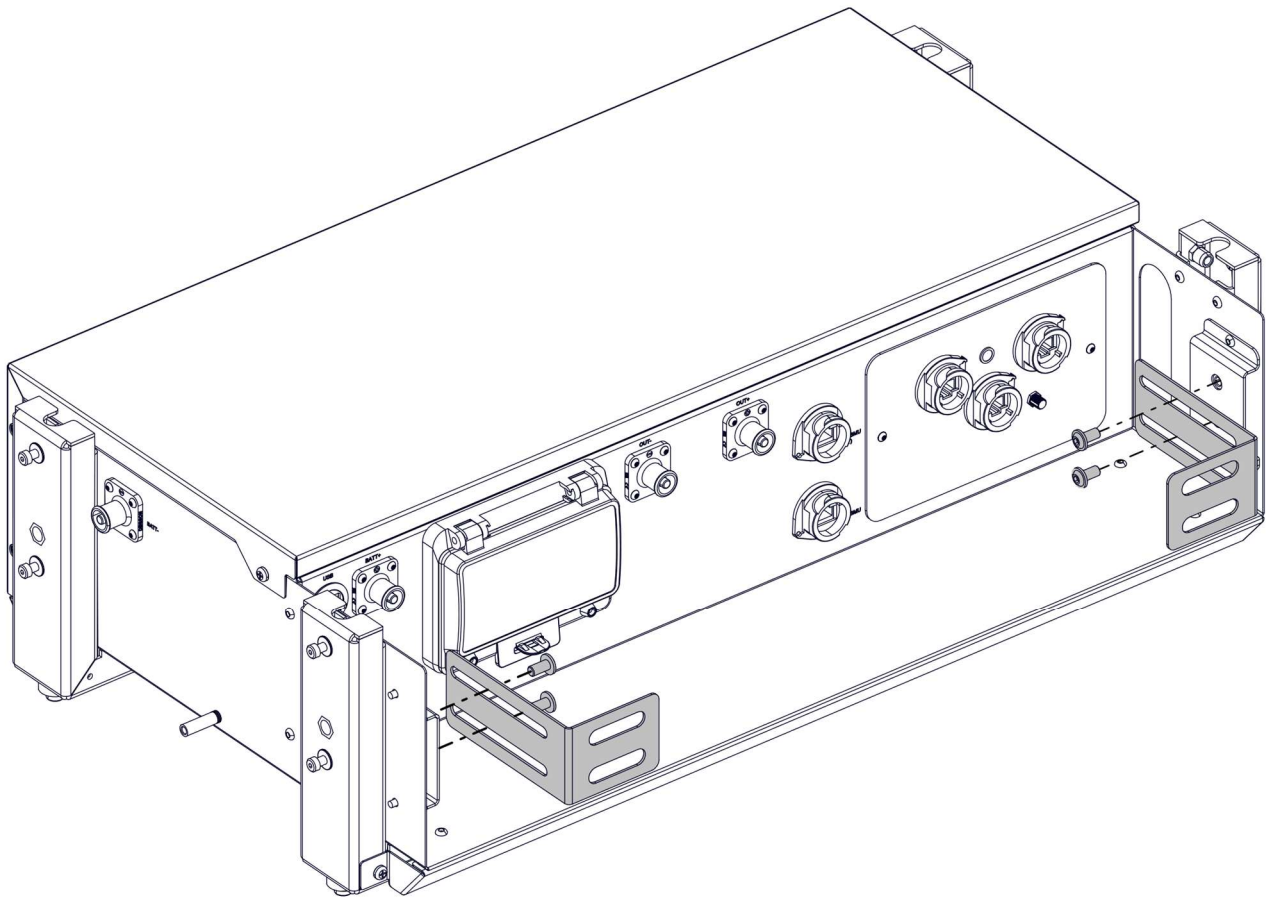

11

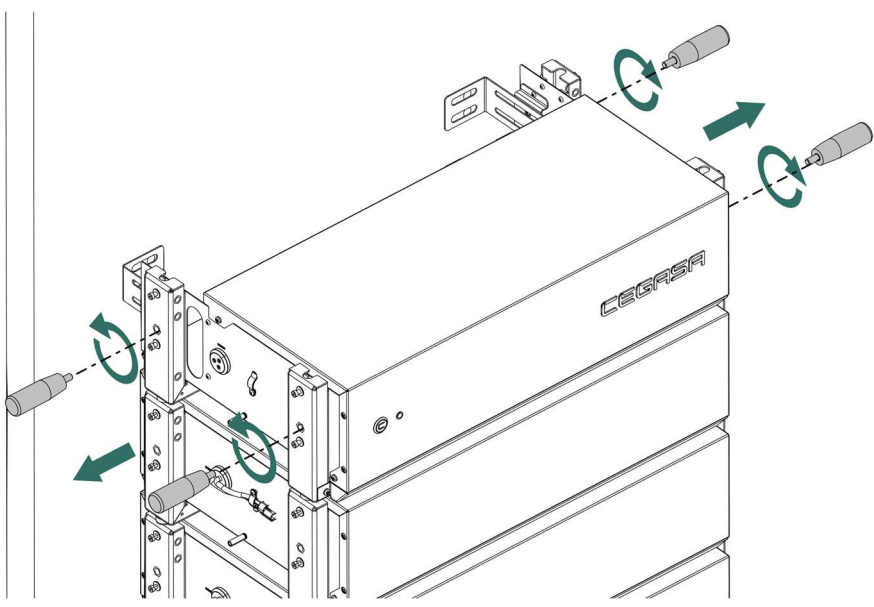
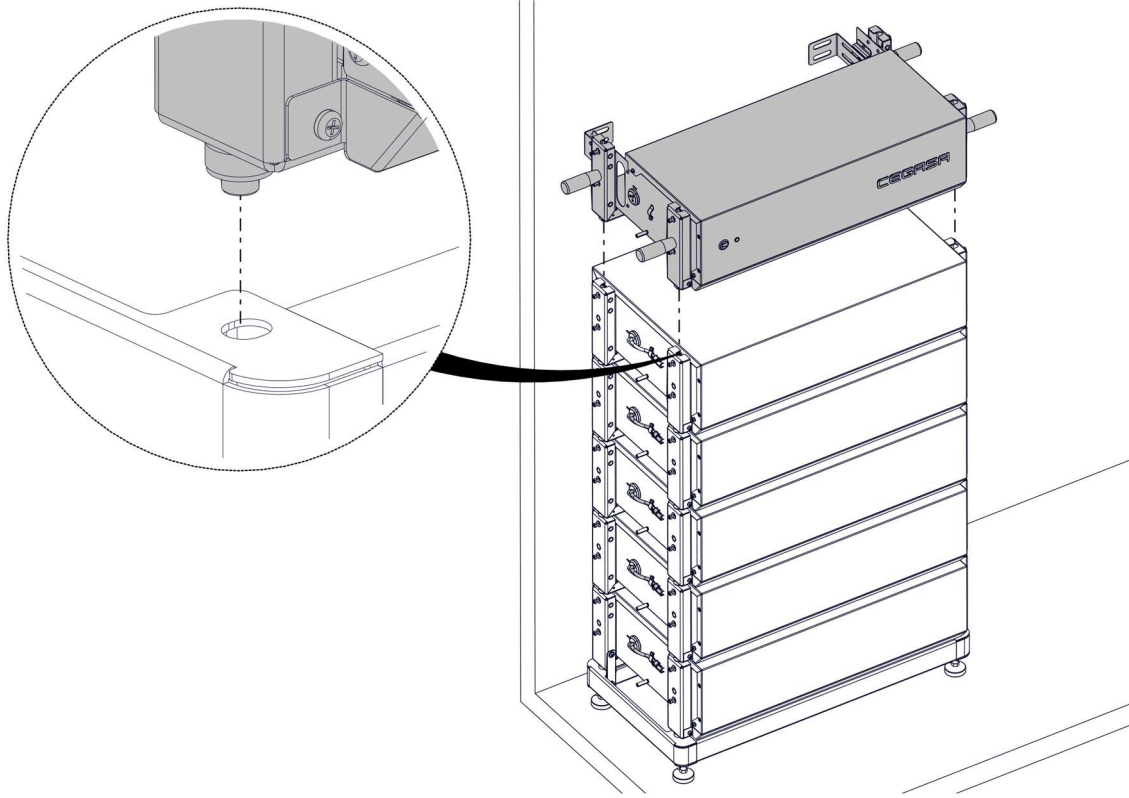
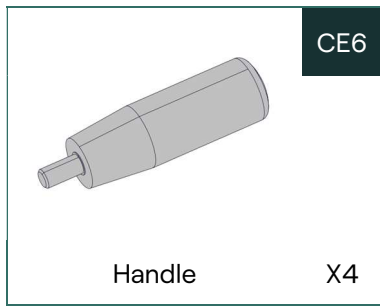
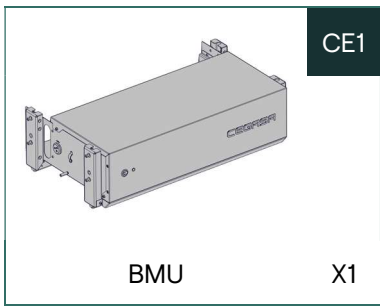

12



CM3

Connection plate 2XN



CM5

M6 Screw 4XN



T11

Torx T30 screwdriver



IMPORTANT: ALWAYS fit the plates. They act as a ground connection between the various modules.

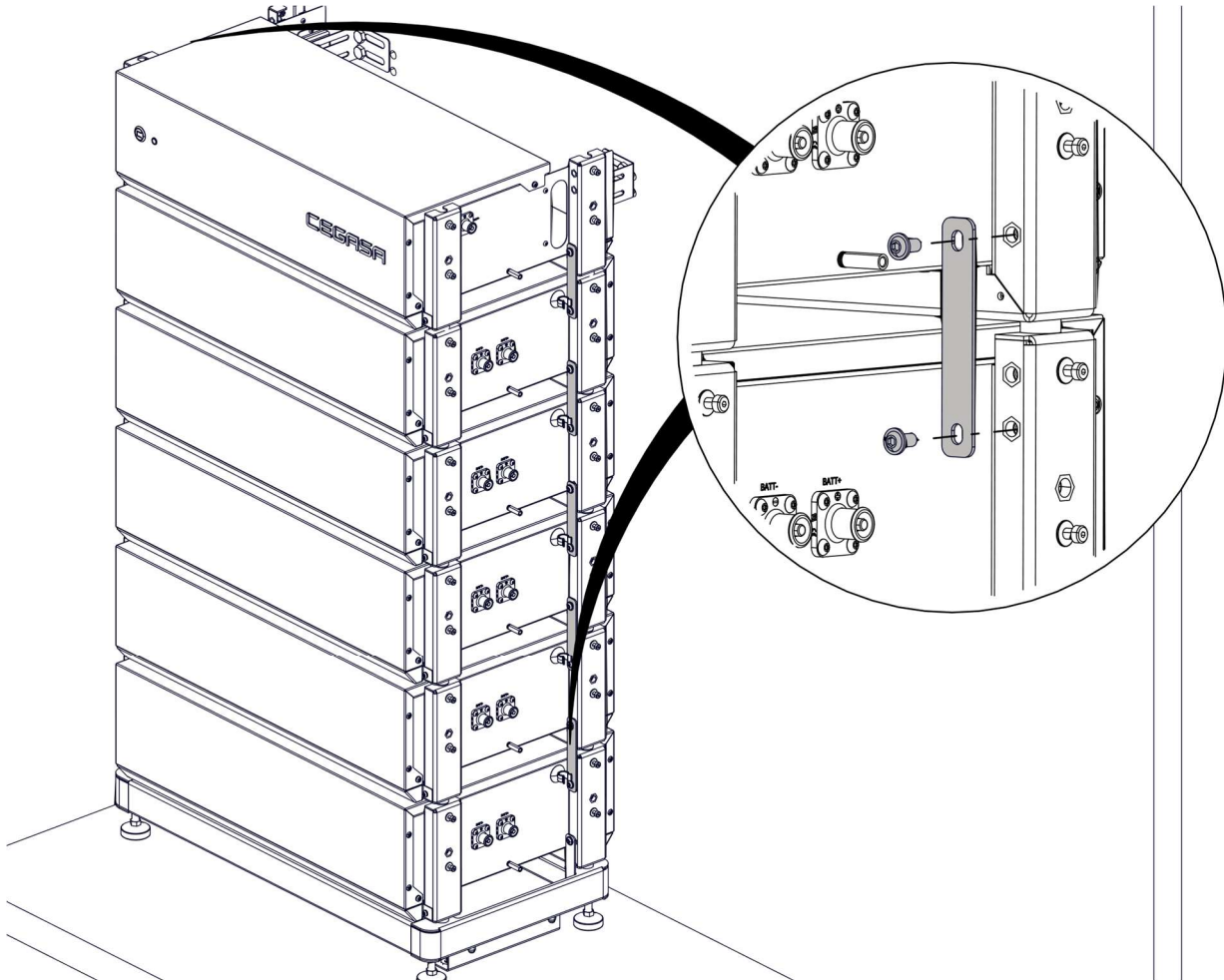

13



This step is only necessary if the tower has 5 Modules or



Use of M6x50 lag screws recommended. The plug is to be selected by the installer. Not provided by CEGASA.

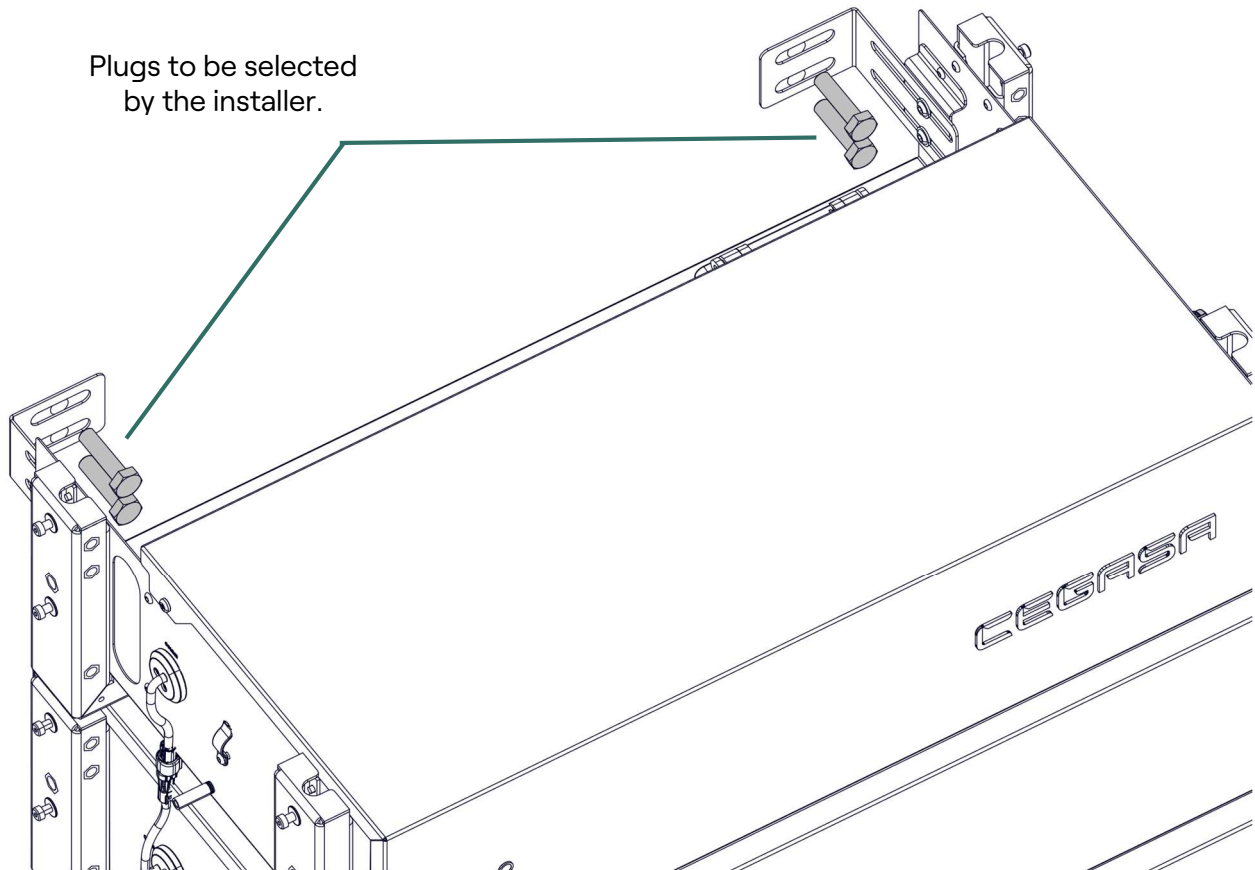

14

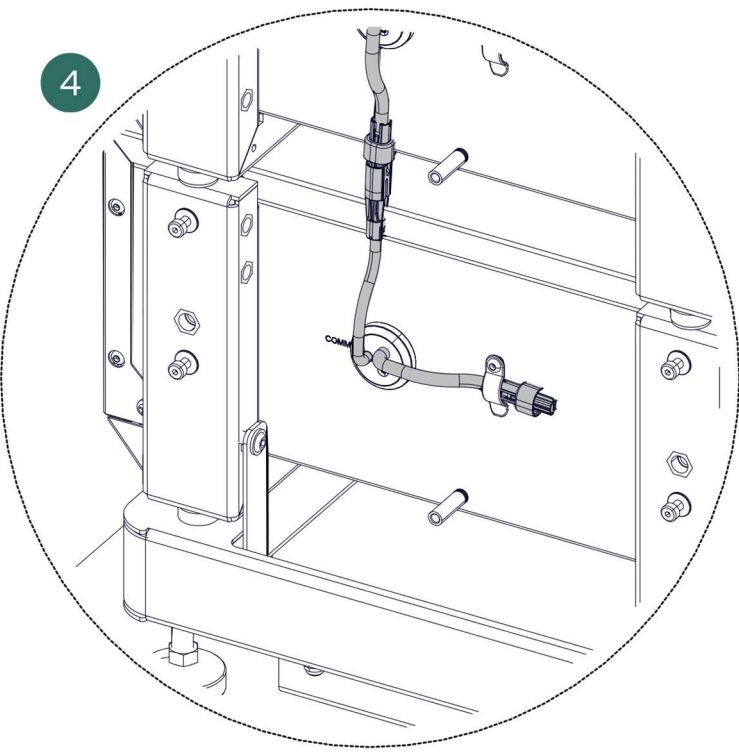
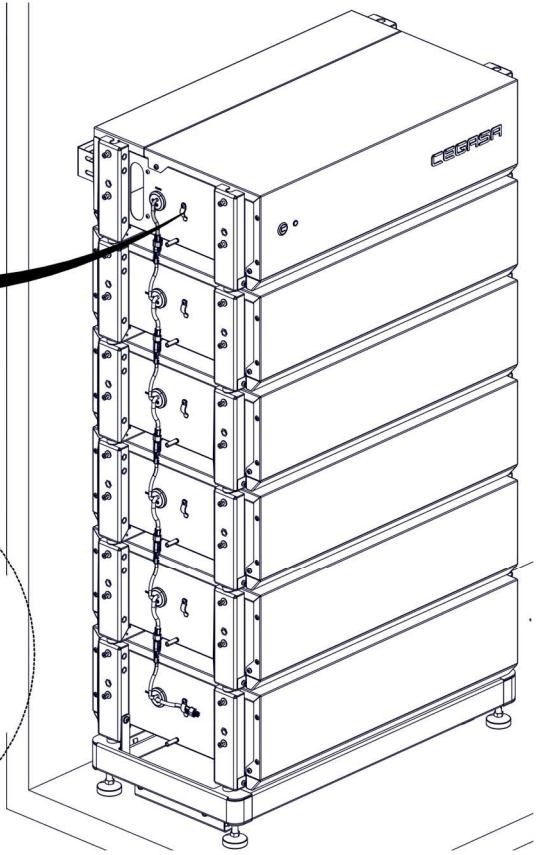
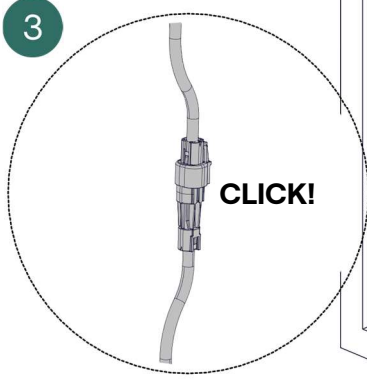
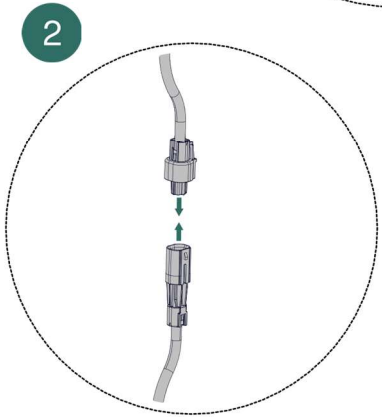
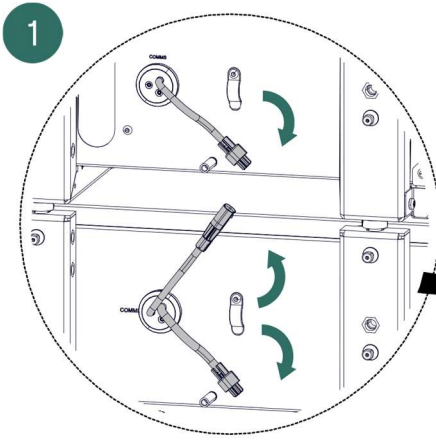

Work downwards on connections from the BMU and gather the cables together into the Module, ensuring they are in a vertical position.



The male COMMS cable from the last Module is not used. Leave it in the position shown in the figure.

15



CM4

Power cable X1



CE5

BMU power cable X1

Work downwards on connections from the BMU

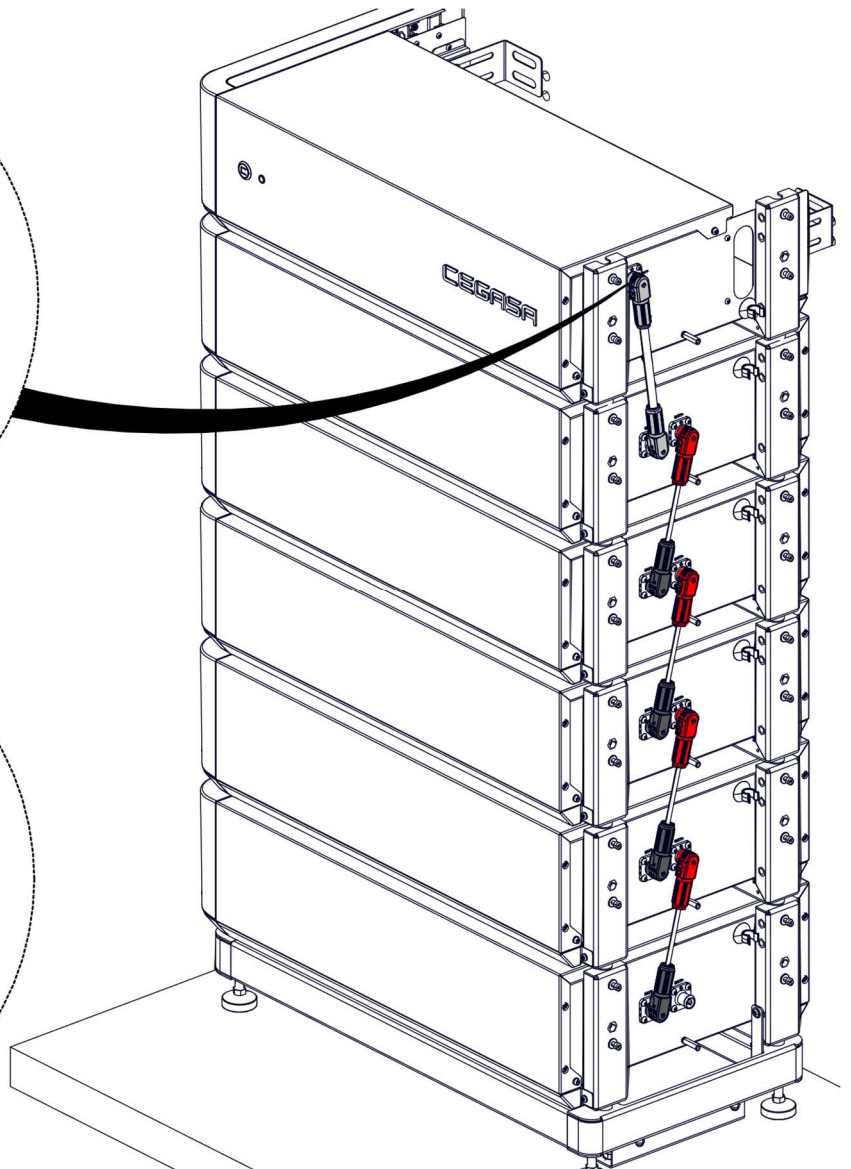
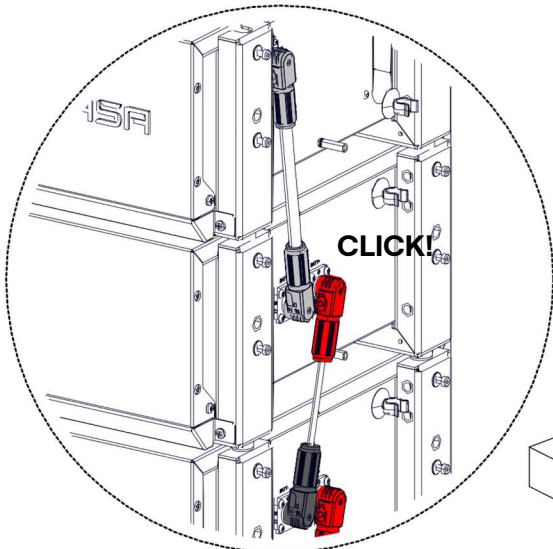
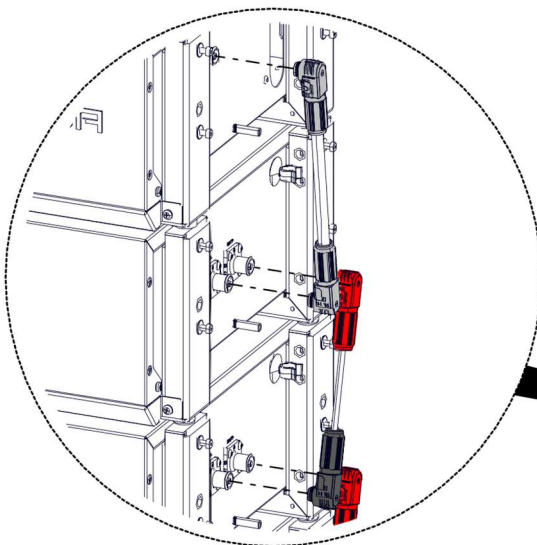

Place the heads with their corresponding connector:
Black = Negative
Red = Positive

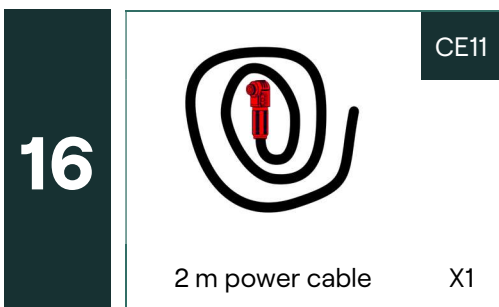

i The size of the cable will depend on the number of Modules that have been installed.

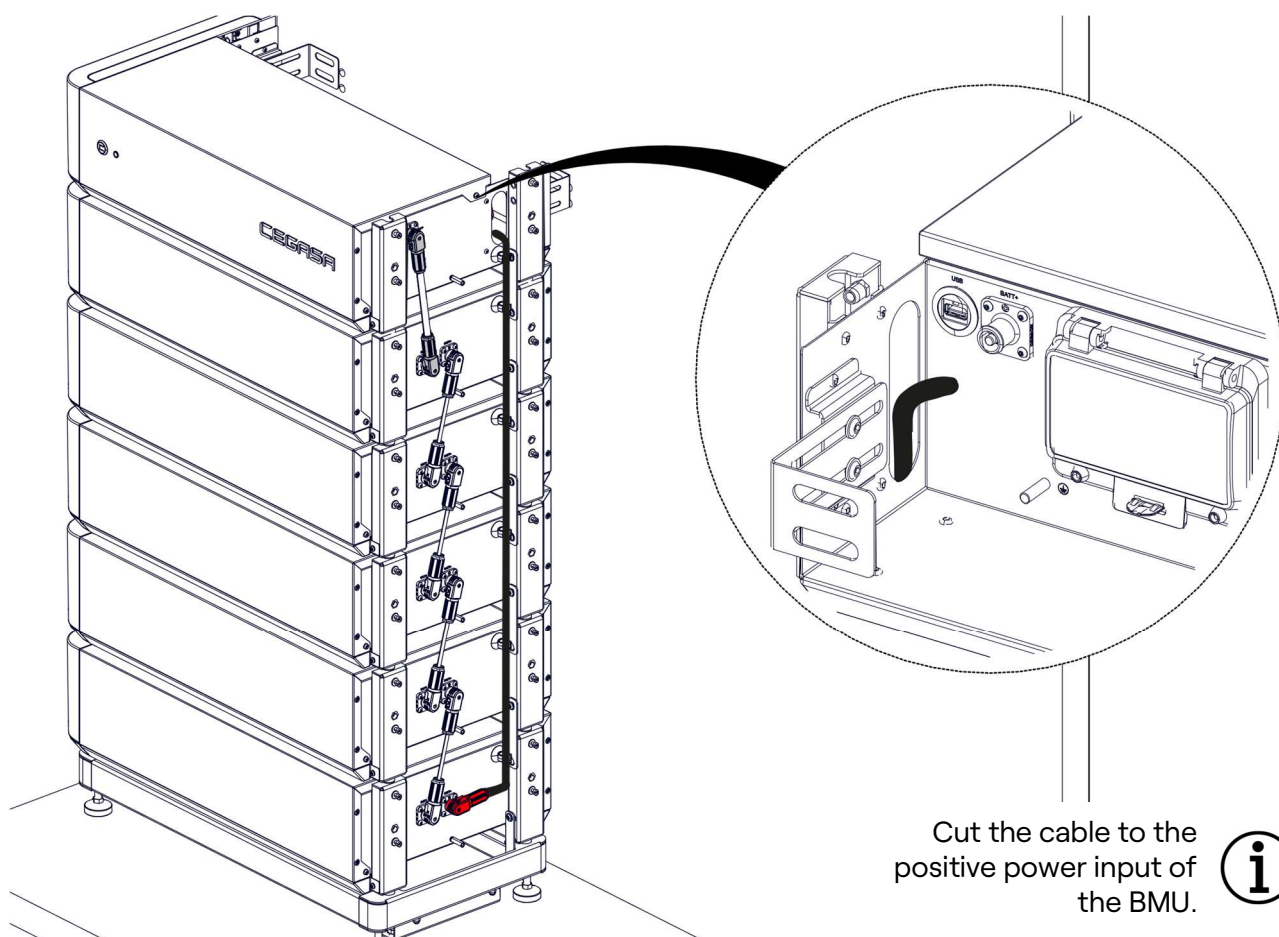

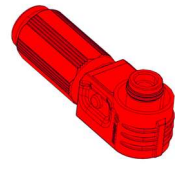
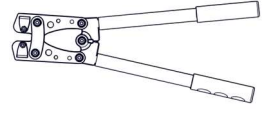

! Take the measurement when the cable is correctly placed in the clamps.

17	 2 m power cable X1	 Female positive power connector X1	 Crimper
	CE11	CE8	T6

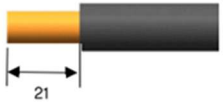

Ensure that the **2 m power cable** is not connected to the Module before carrying out the following actions.

1 
21

2 

3 

Check that the cable is well crimped. If in doubt, contact CEGASA.

Crimp the positive aerial connector 21 mm (± 1).

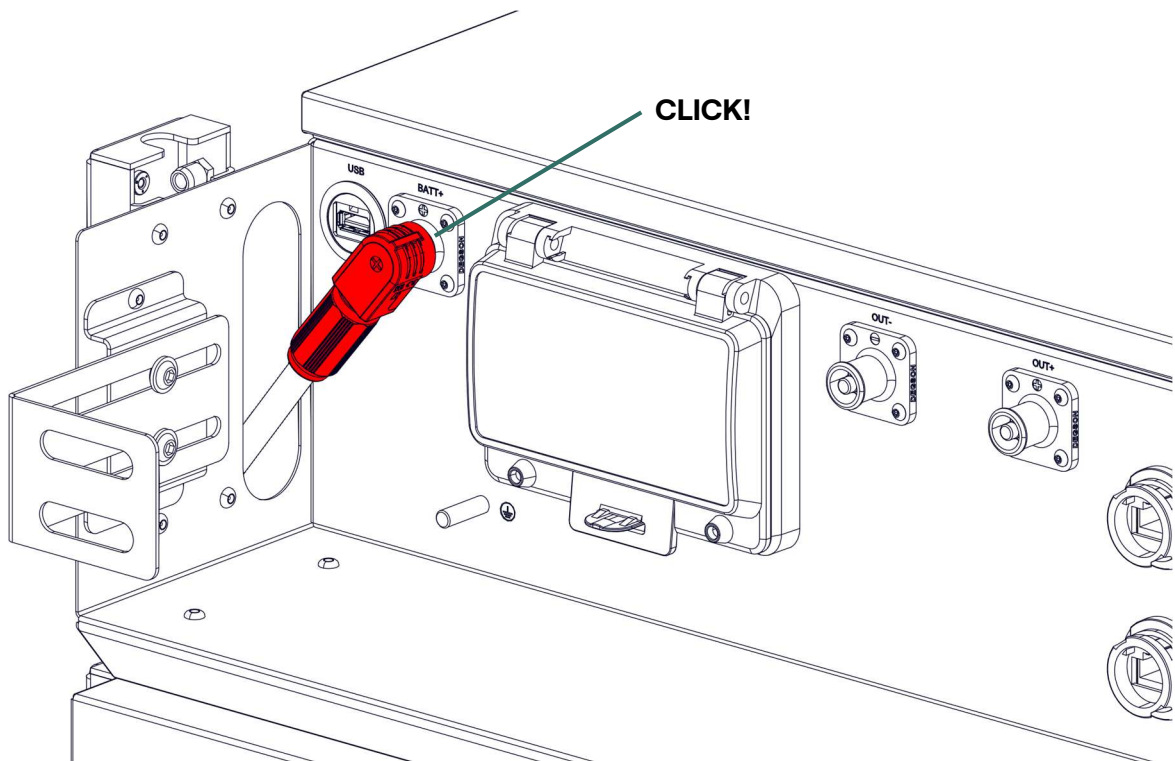

18

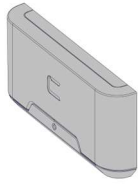

CE2

BMU side cover

X2

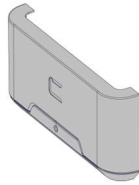

CM2

Module side cover

2XN



T4

2.5 Allen key



Before placing the cover, make sure the screw is out.

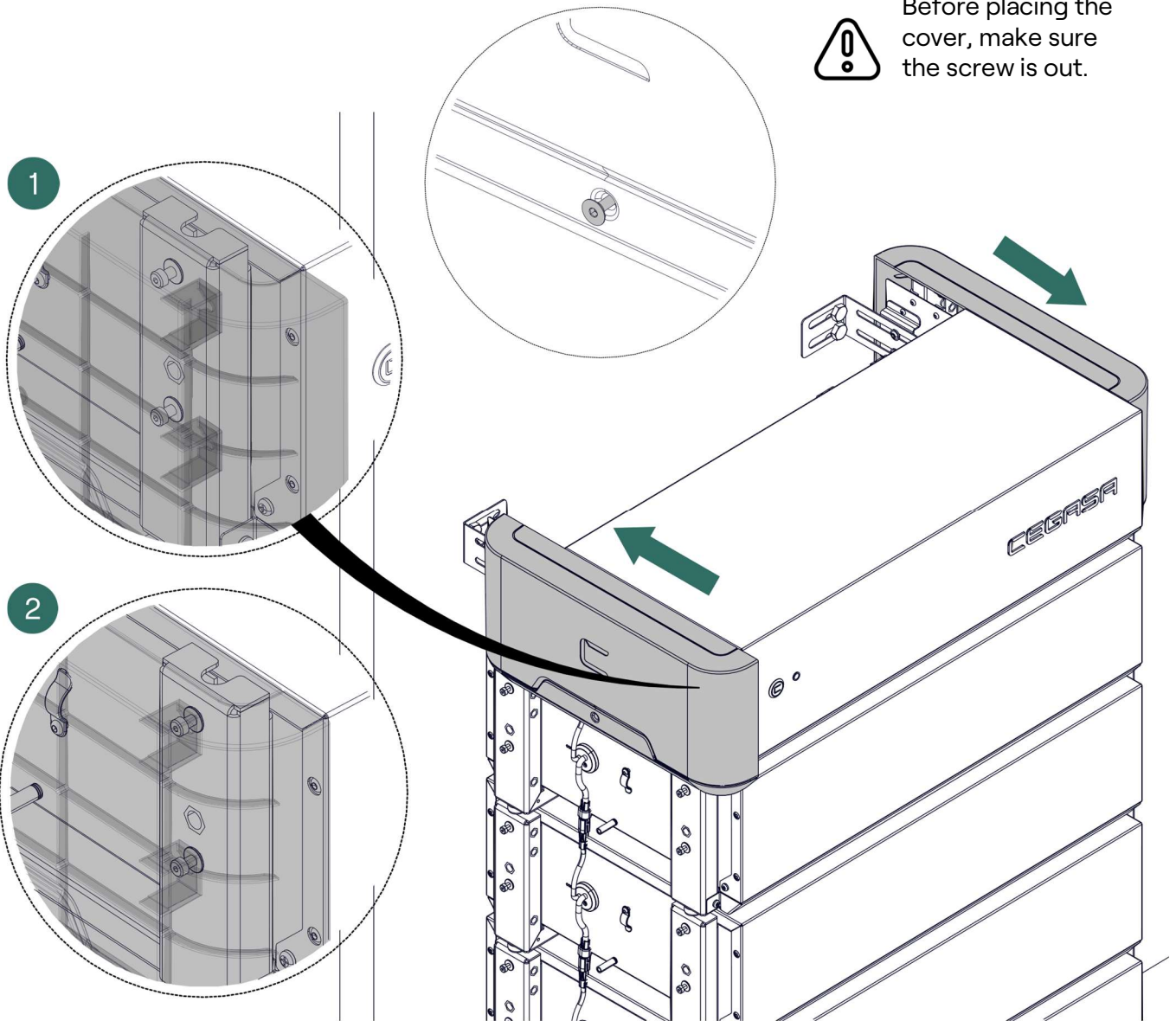

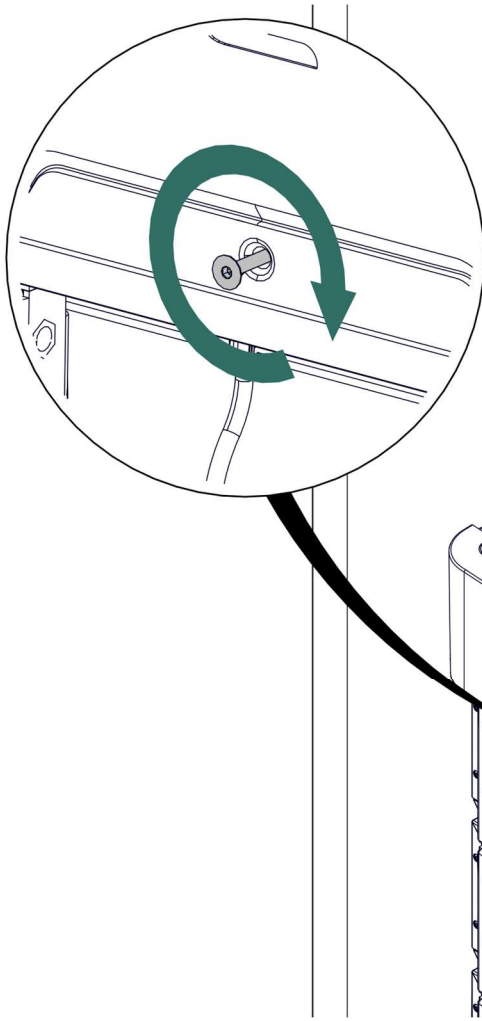

The cover and Module attachment screws are located inside the inner rails of the cover.

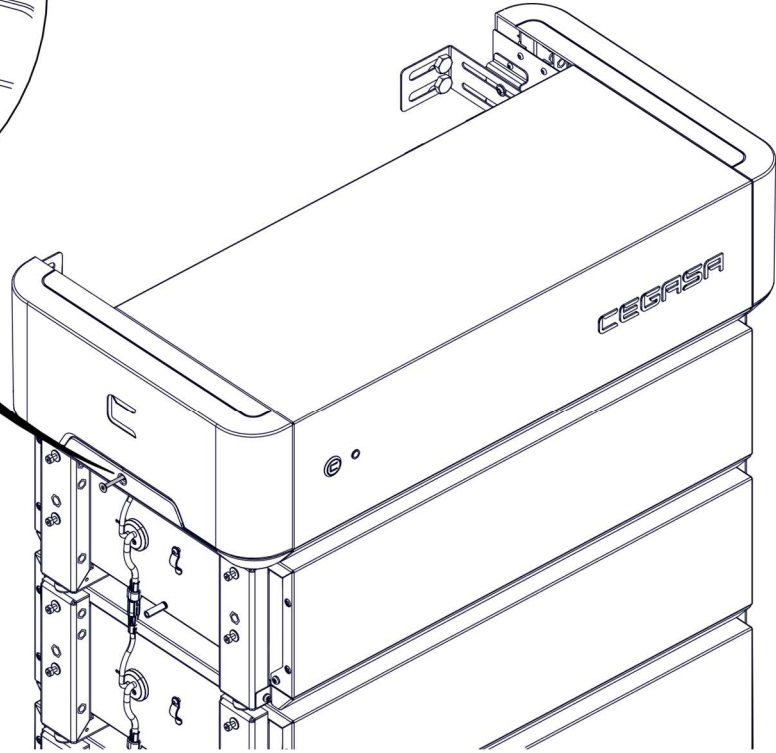

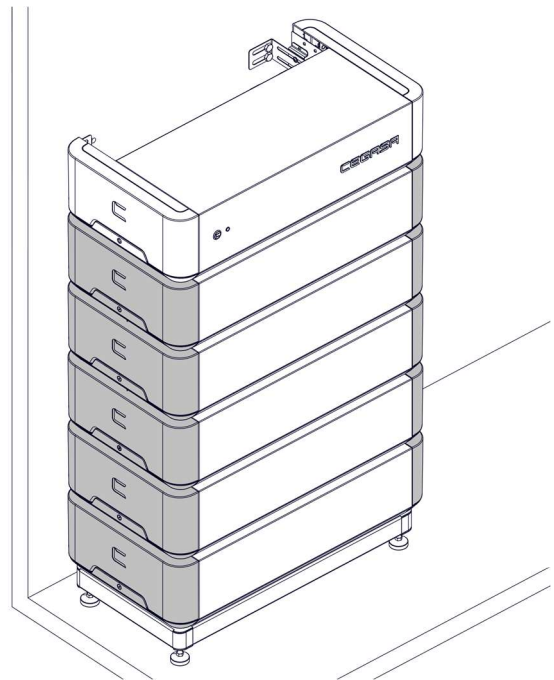

Place all the covers in the same way.

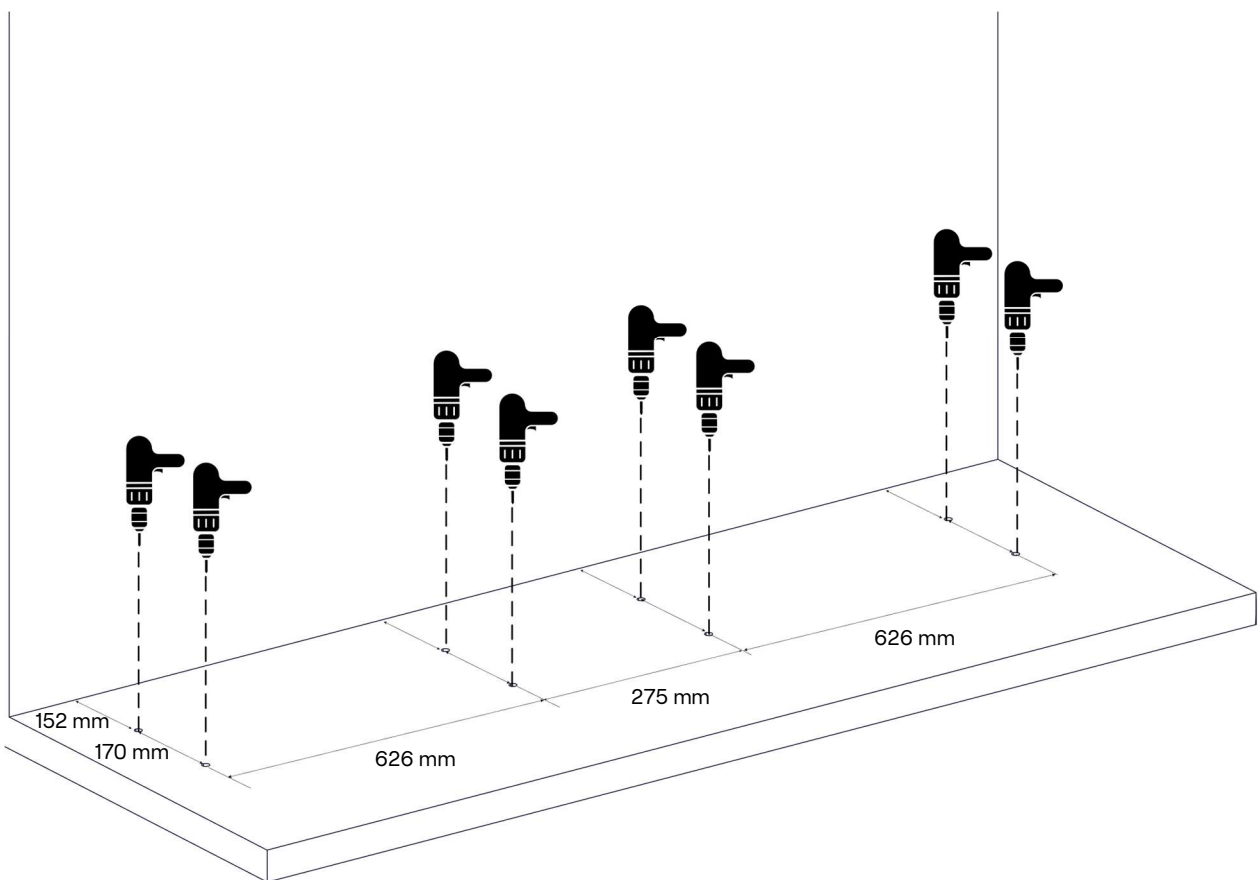
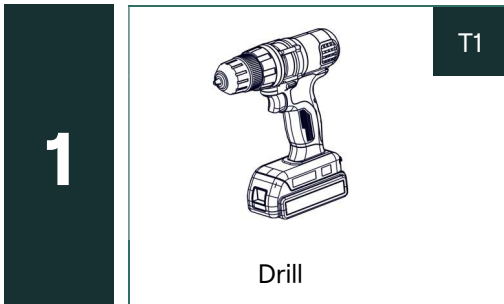

4.2 TWO TOWERS

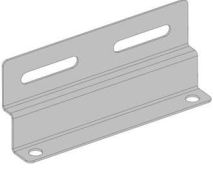

i Use of M12 metal expansion bolts is recommended. Not provided by CEGASA.

2	 Floor ties	CP2 X4	 Spanner	T7

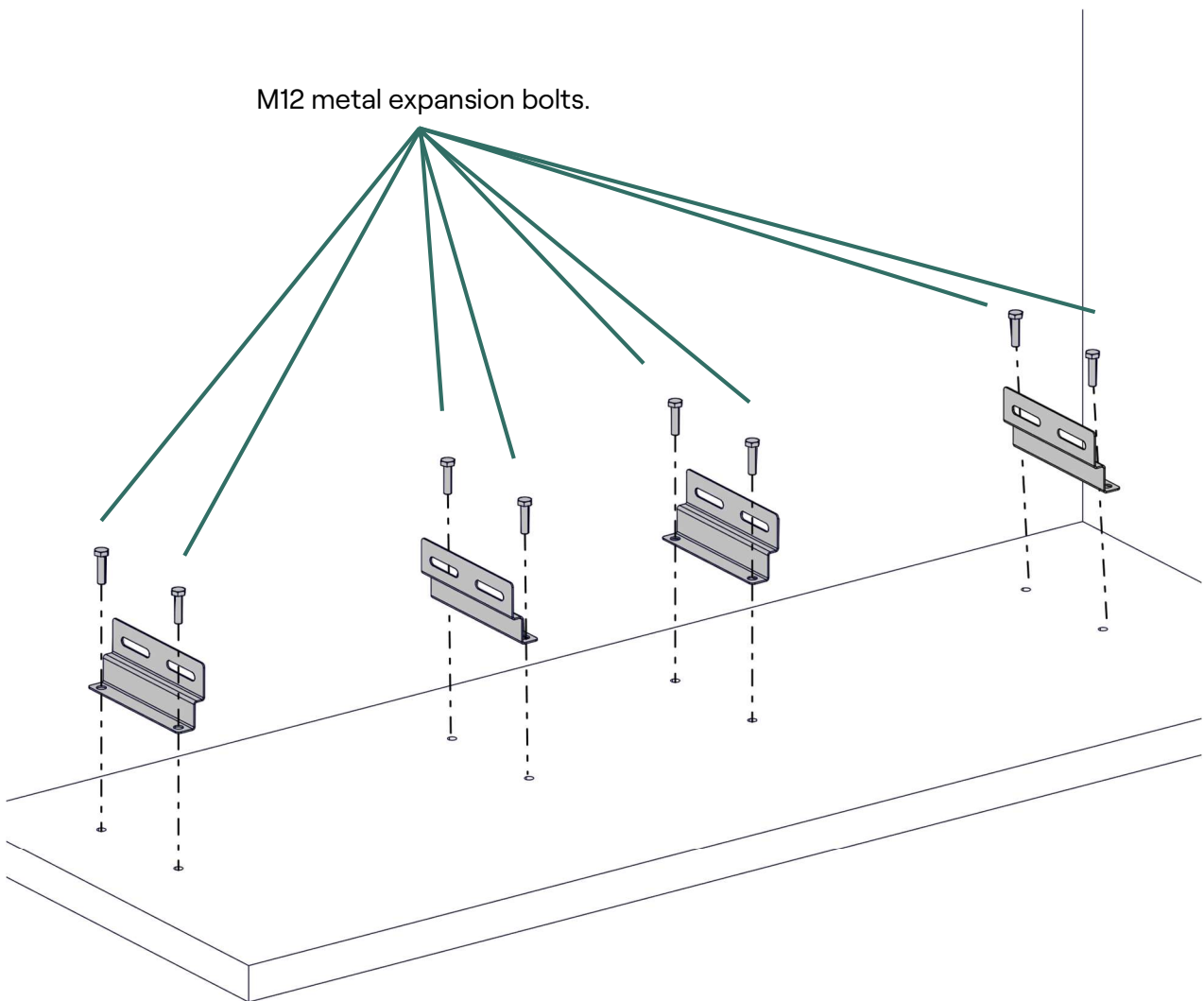

Use of M12 metal expansion bolts is recommended. Not provided by CEGASA.

3

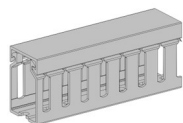

Wiring duct

X1





Placement of an approx. 1350 mm long wiring duct recommended.
Not provided by CEGASA.

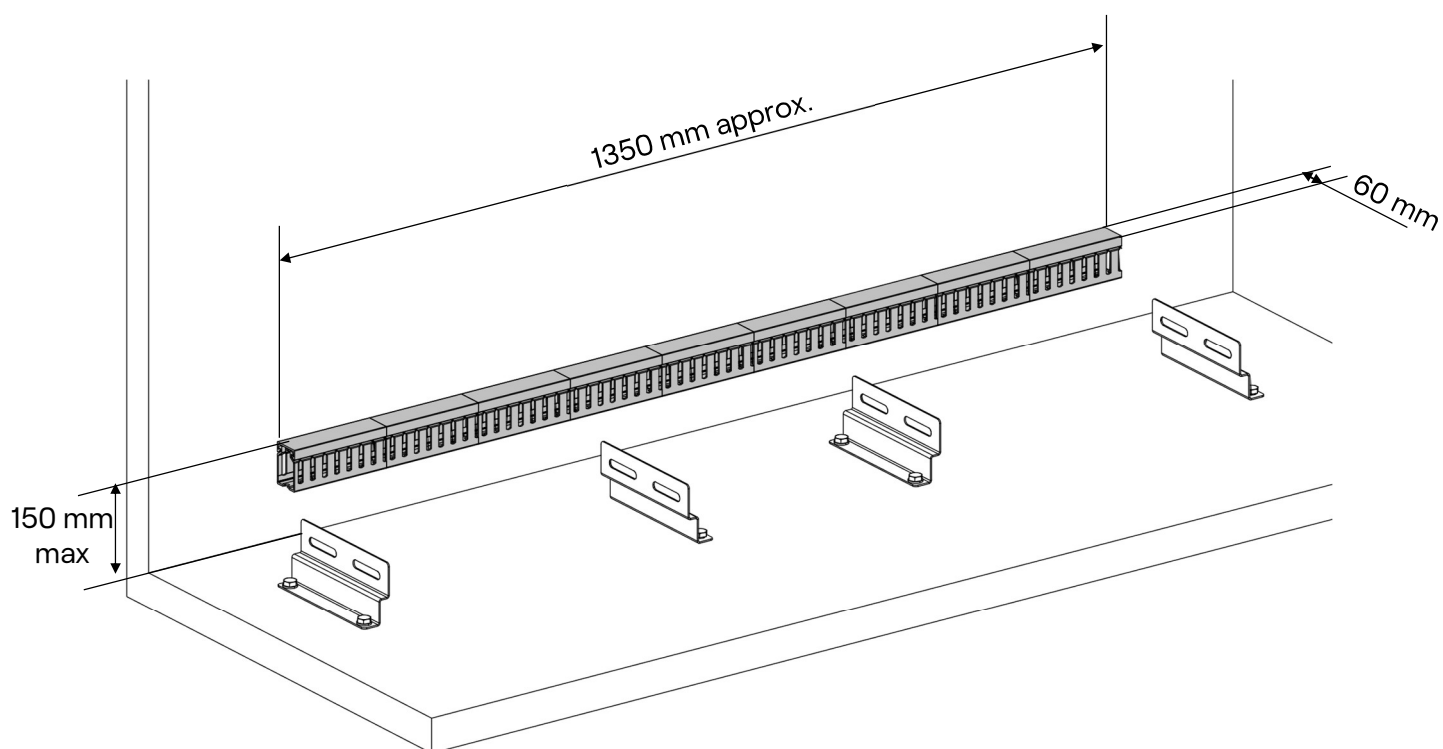

Do not use a wiring duct more than 60 mm wide.

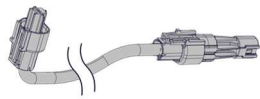

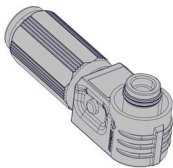
4	CT6		CE11		CT4	
	1.8 m COMMS cable	X1	2 m power cable	X1	Female negative power connector	X1

i Mind the position of connectors.

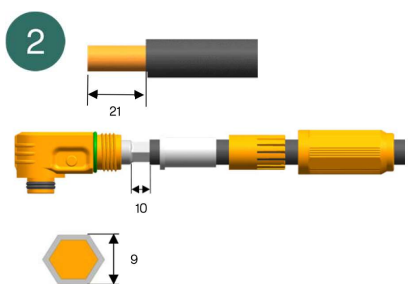
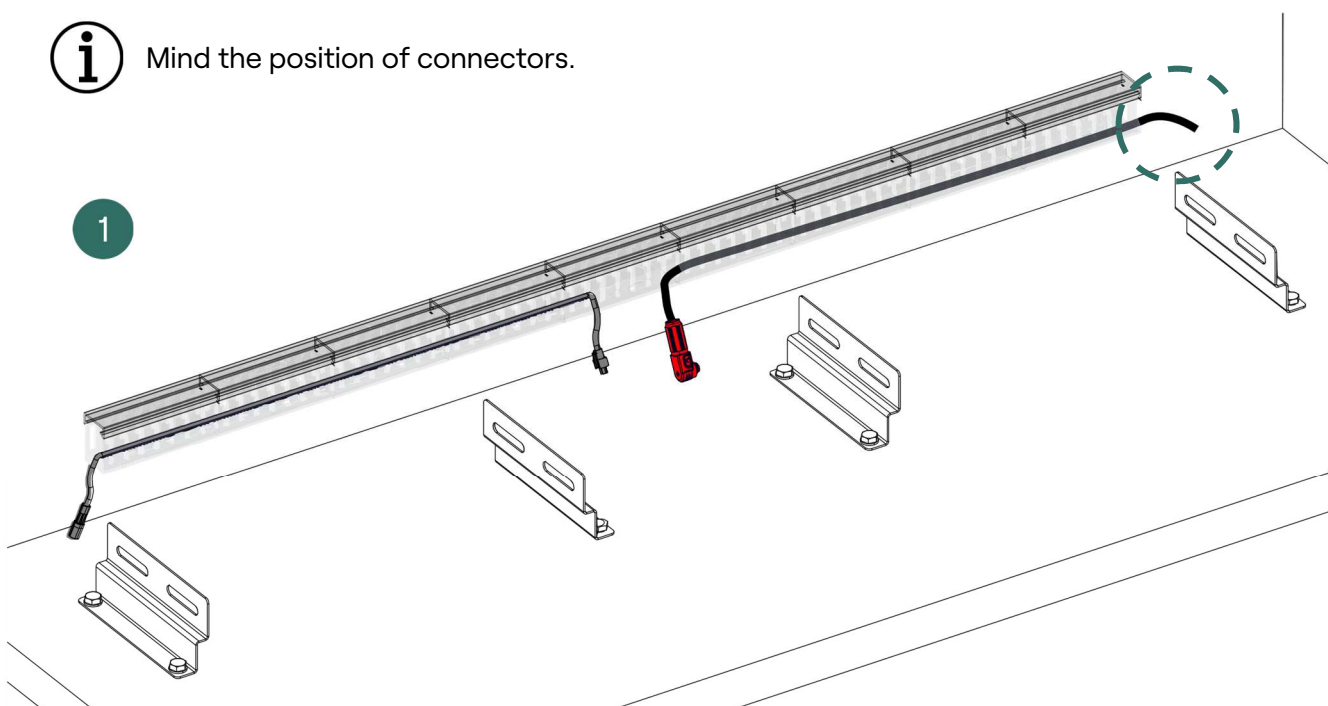

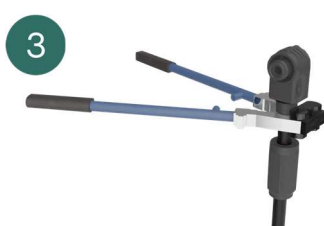

Crimp the negative aerial connector 21 mm (±1).

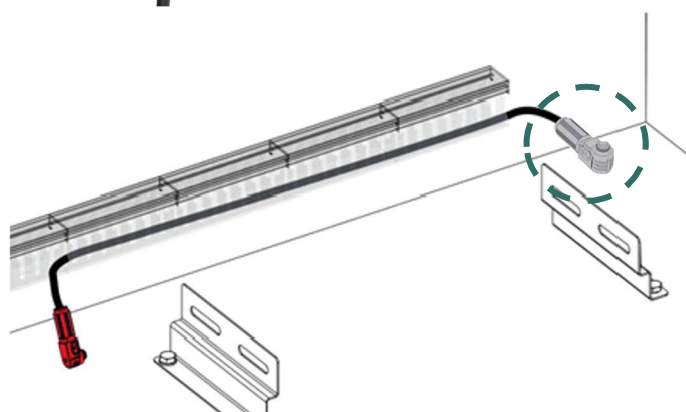

Check that the cable is well crimped. If in doubt, contact CEGASA.

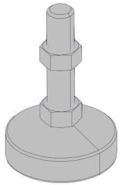
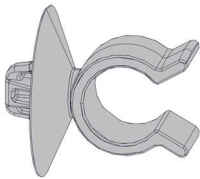

5		CP3
	Levelling foot	X4
		CP7
	Clamp	X1
		T7
	Spanner	

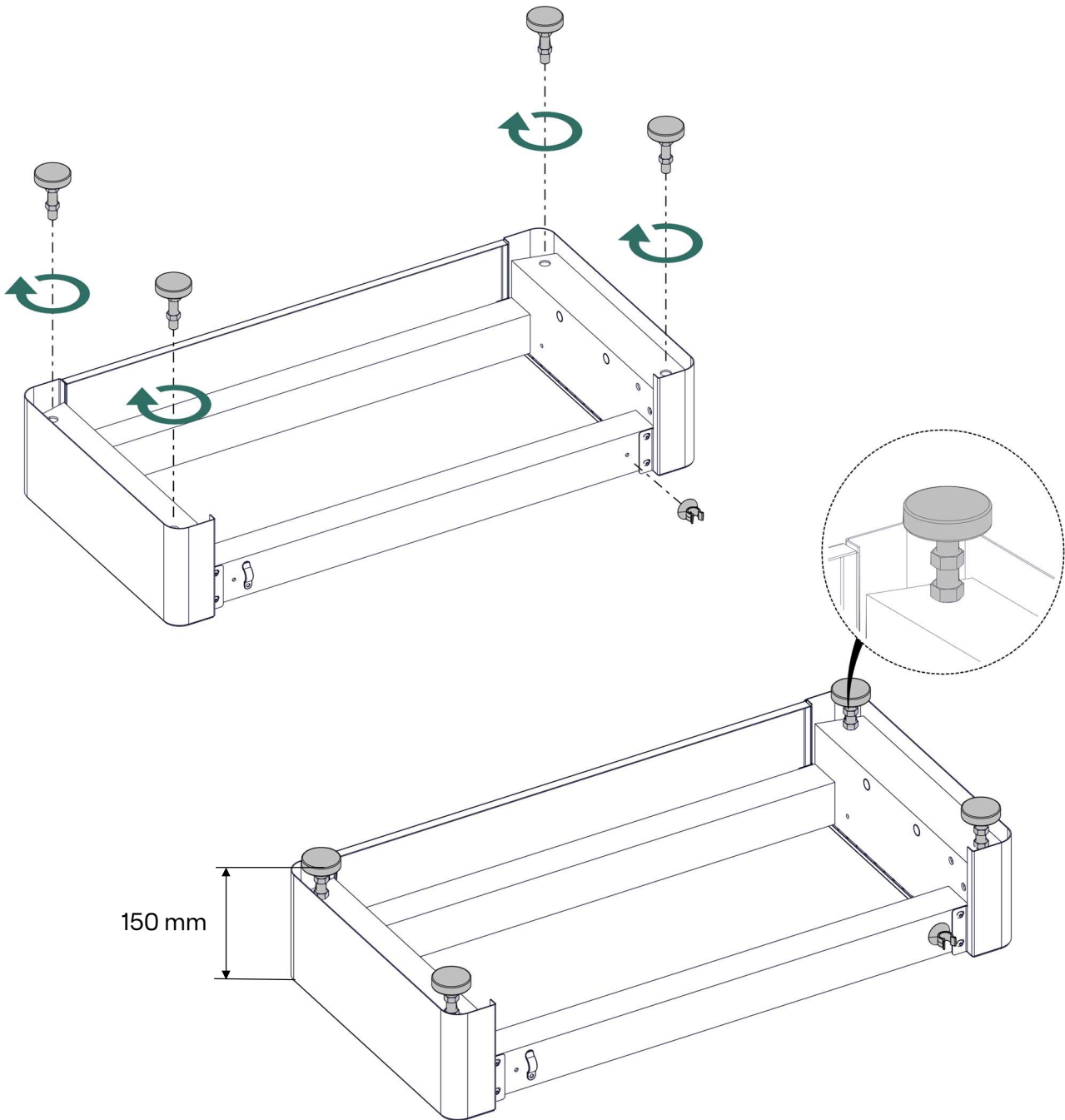

6

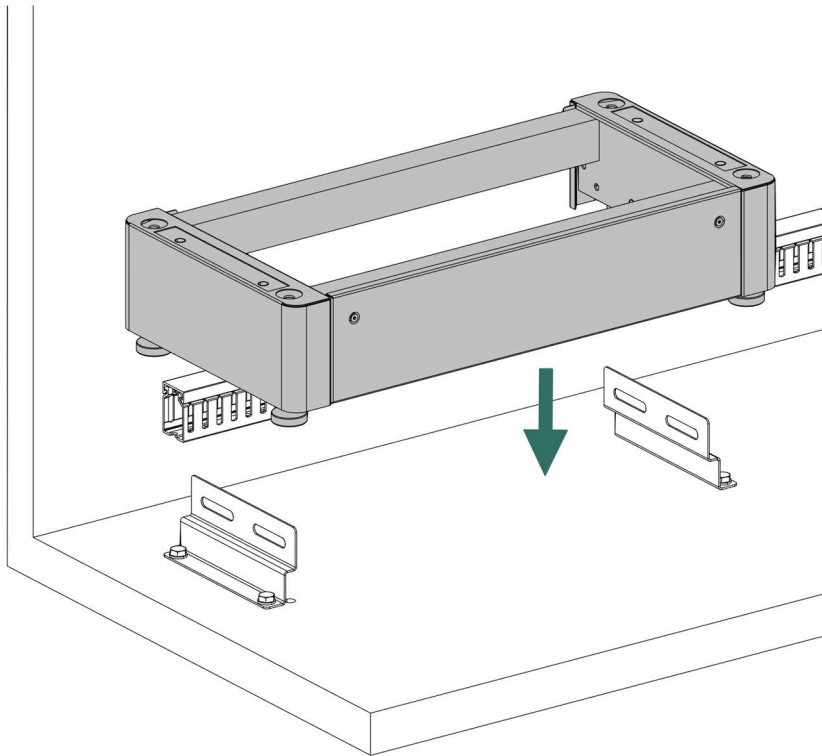
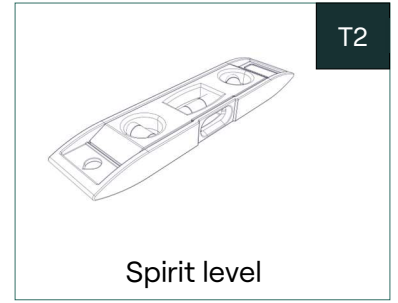
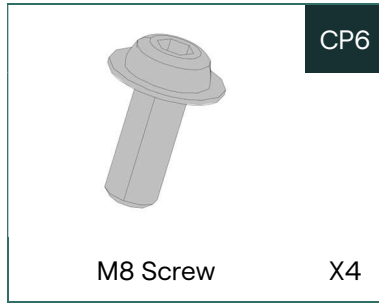
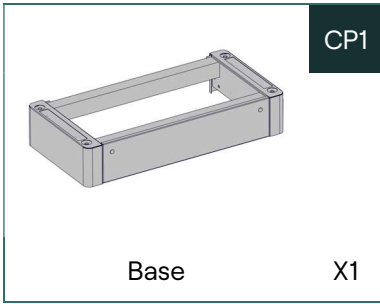

Check the levelling and adjust the feet if necessary.

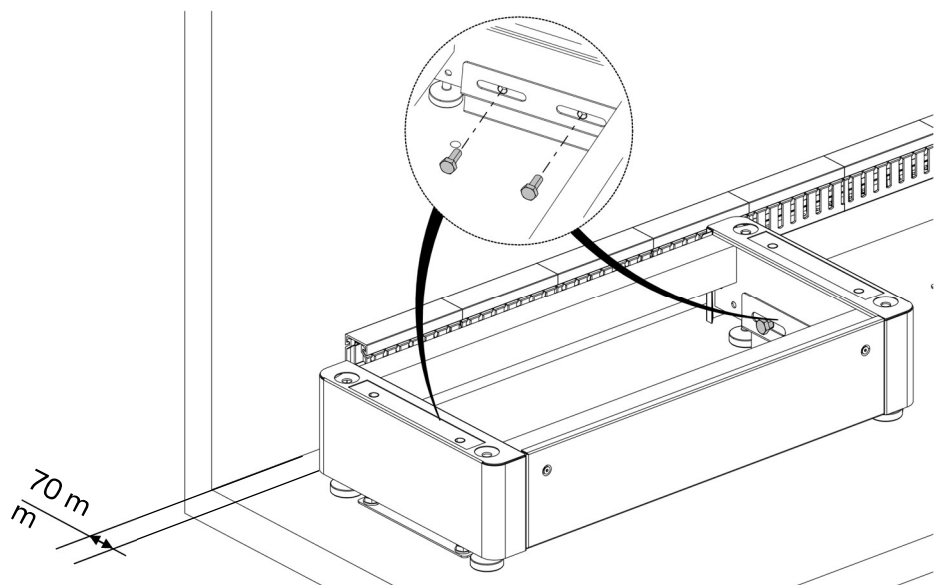

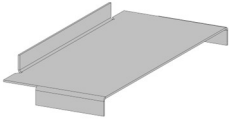
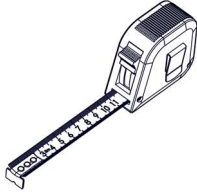
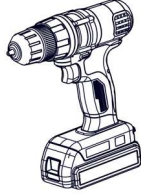
7	 Base fixture X1	 Tape measure	 Drill
	CE10	T3	T1

1



This step is only necessary if the tower has 5 Modules or

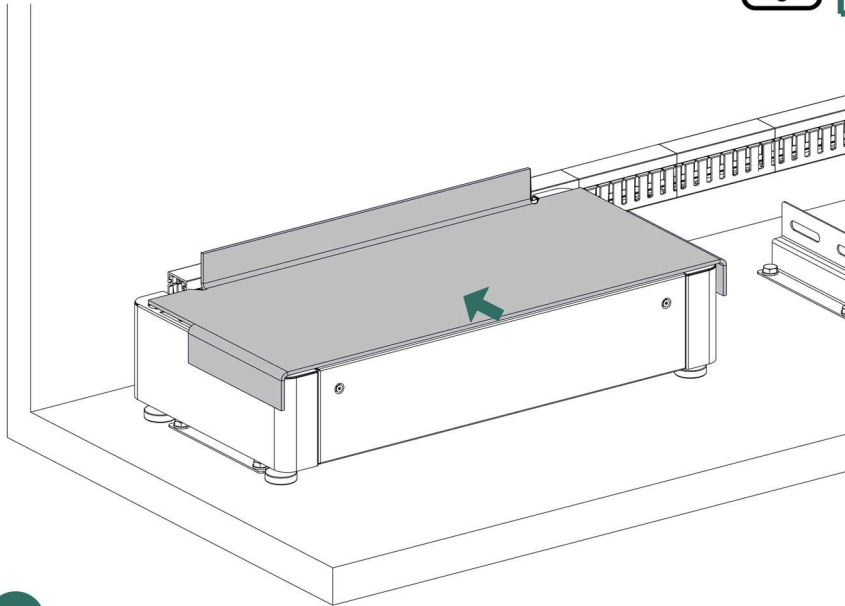

2

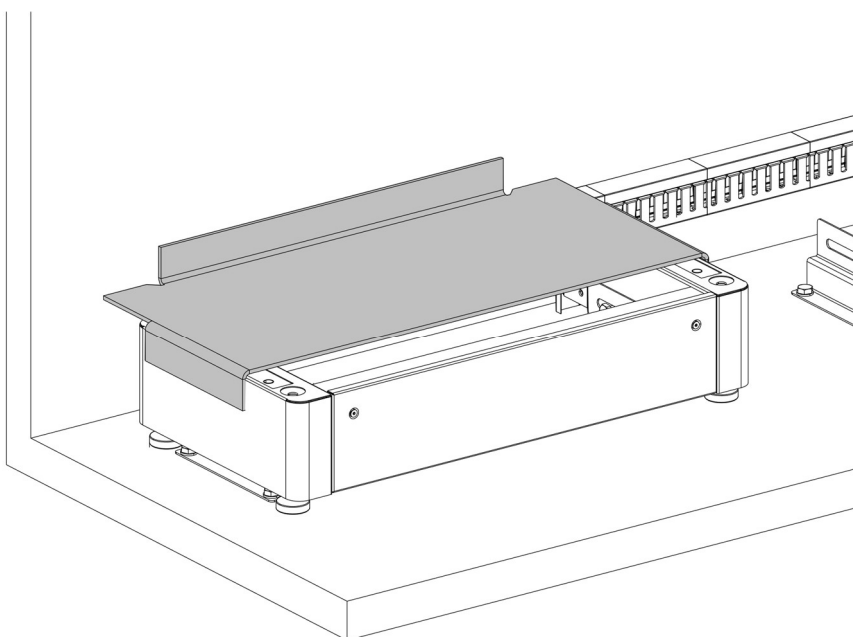

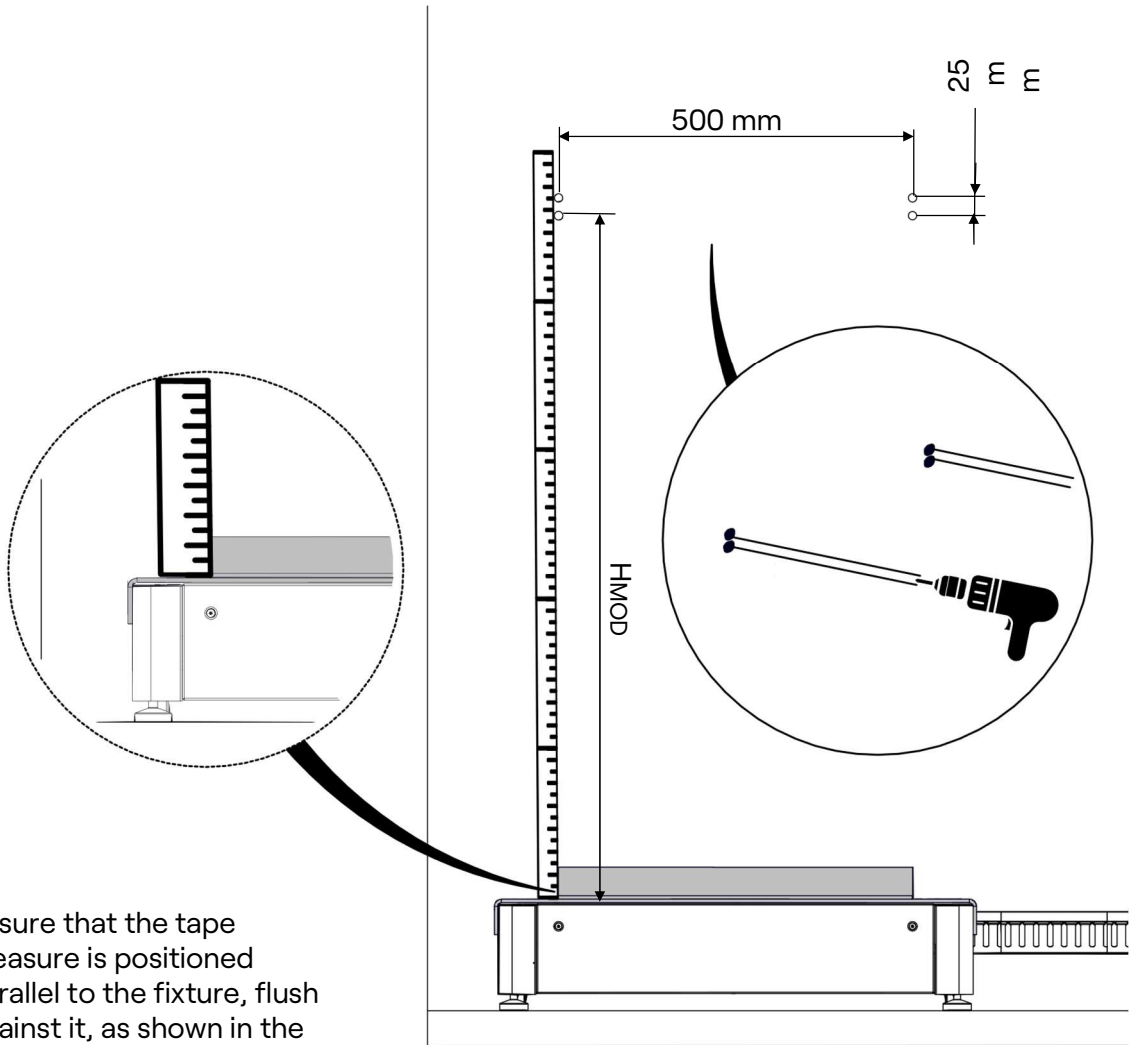

Ensure that the tape measure is positioned parallel to the fixture, flush against it, as shown in the image.

No. MODULES	HMOD
5	977 mm
6	1156 mm
7	1334 mm
8	1512 mm

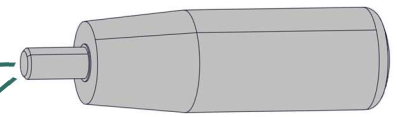
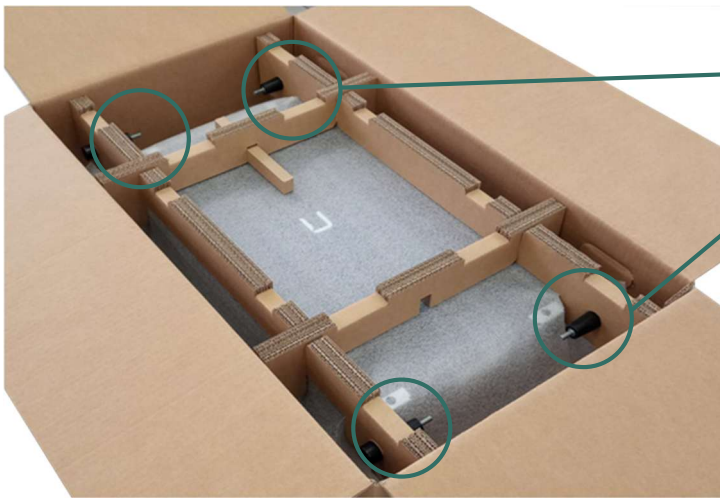
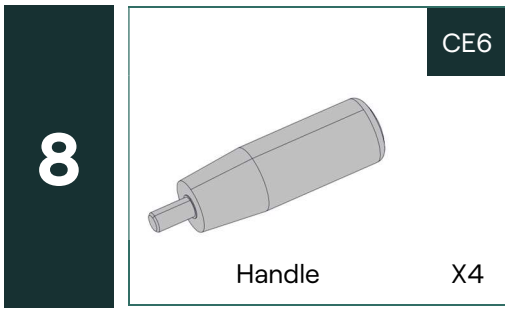

i The handles can be found inside the BMU.

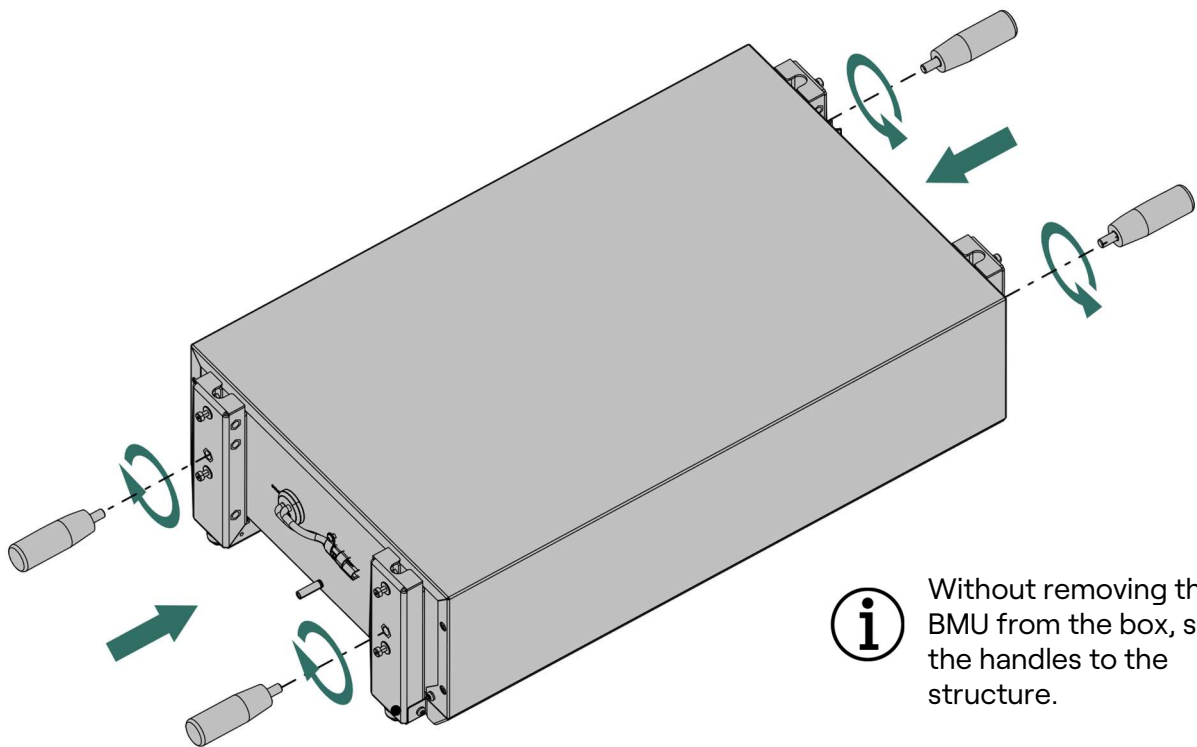

i Without removing the BMU from the box, screw the handles to the structure.

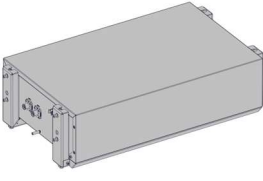
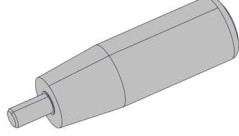
9	 Module X1	 Handle X4

Step to be performed by two 

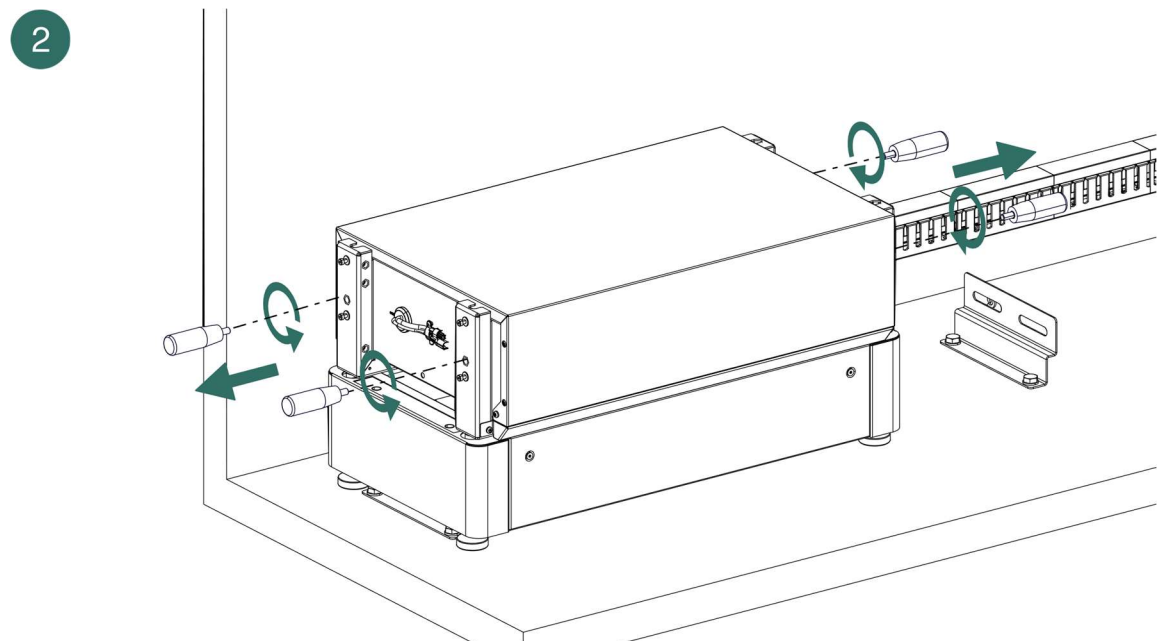
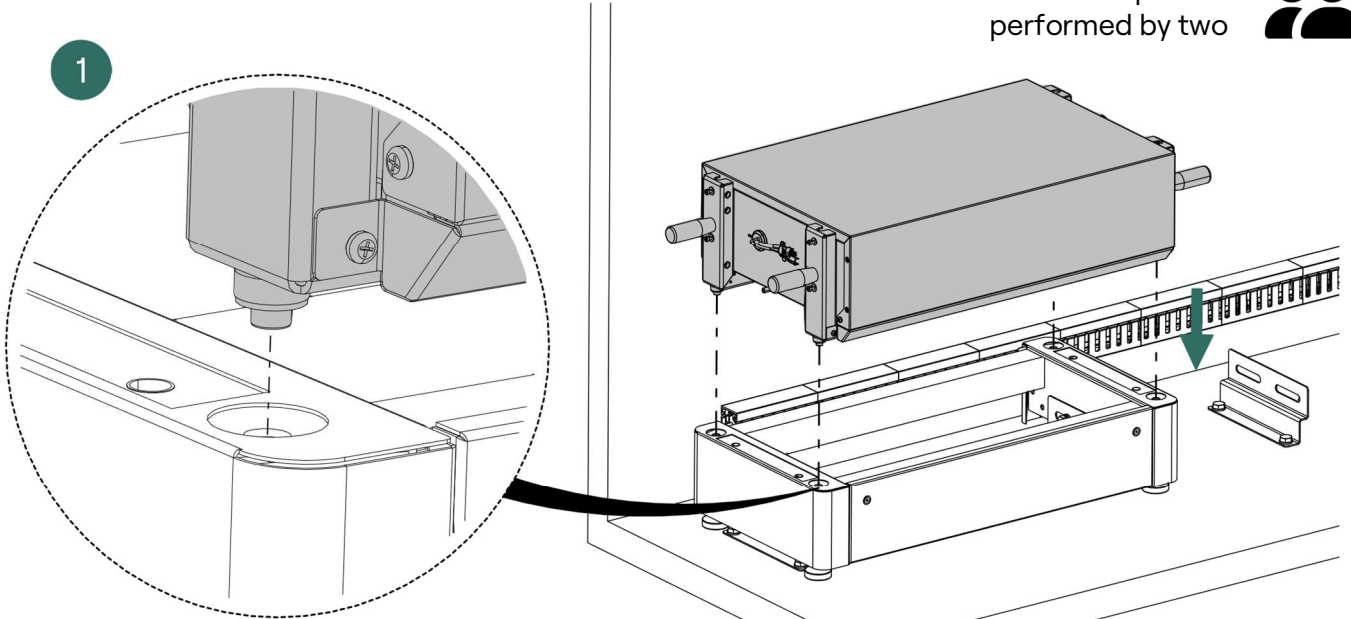

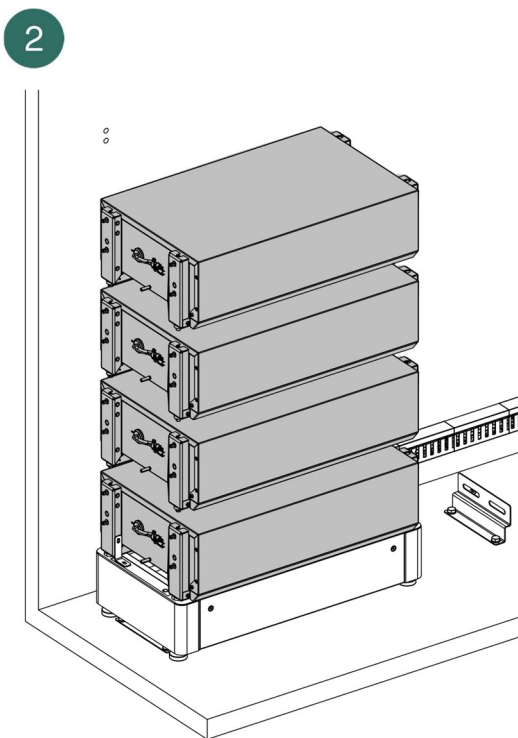
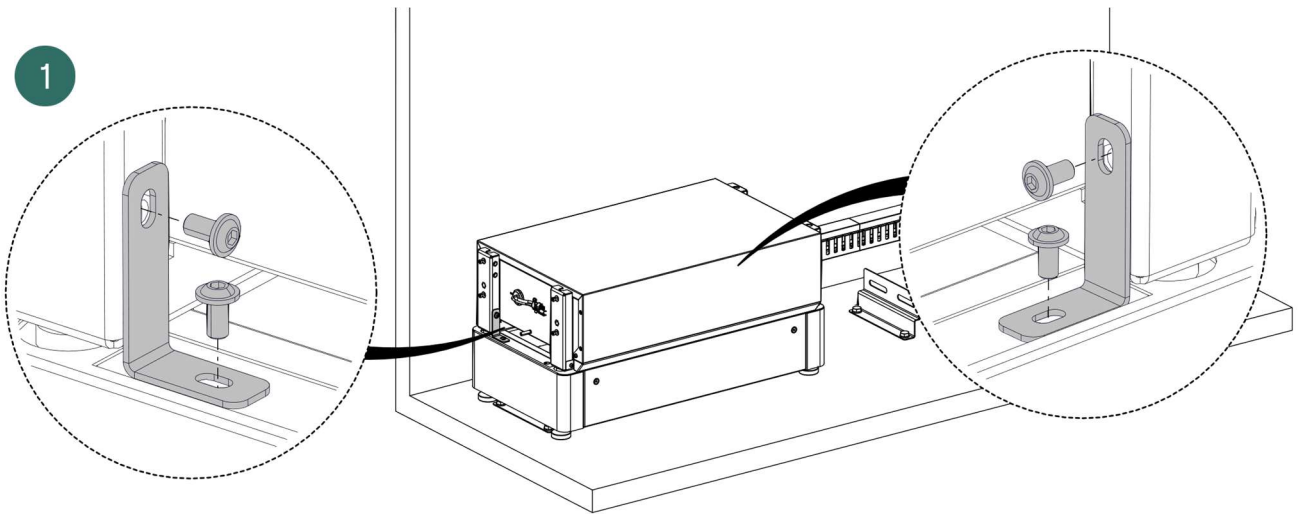

10	 CP4 Connection plate X2	 CP5 M6 Screw X4	 T11 Torx T30 screwdriver
-----------	---	---	--



Place the desired number of Modules, from 3 to 8 batteries. The installation is the same as that of the lower Module.

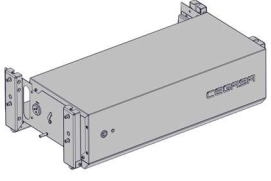
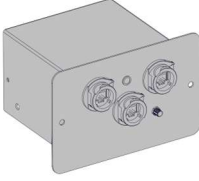

11	 BMU X1	 Master x1	 Torx T20 screwdriver
	CE1	CC1	T10

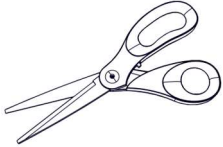
 Scissors	T8
---	-----------

1

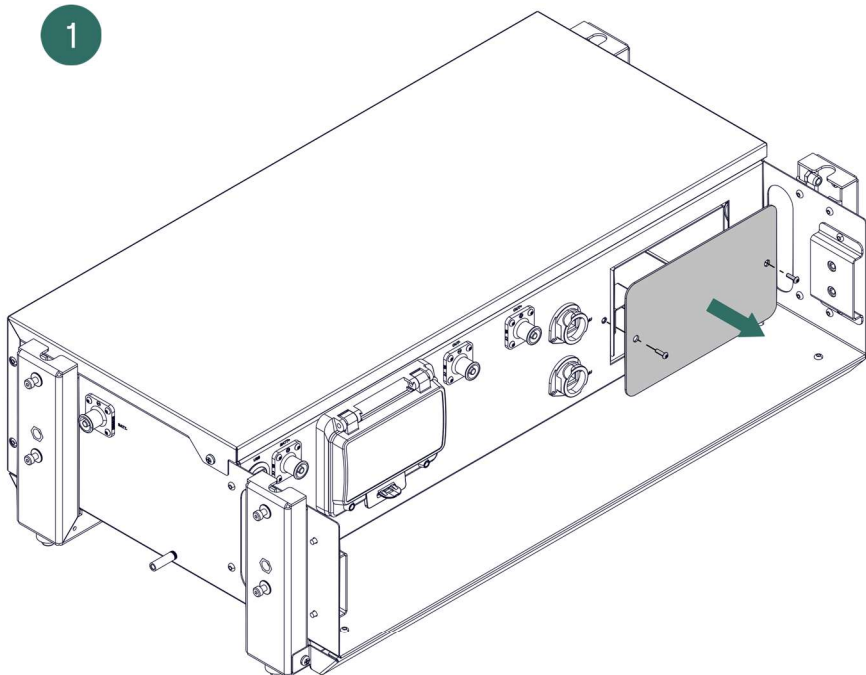

Be sure not to damage the cable when cutting the tie with scissors.

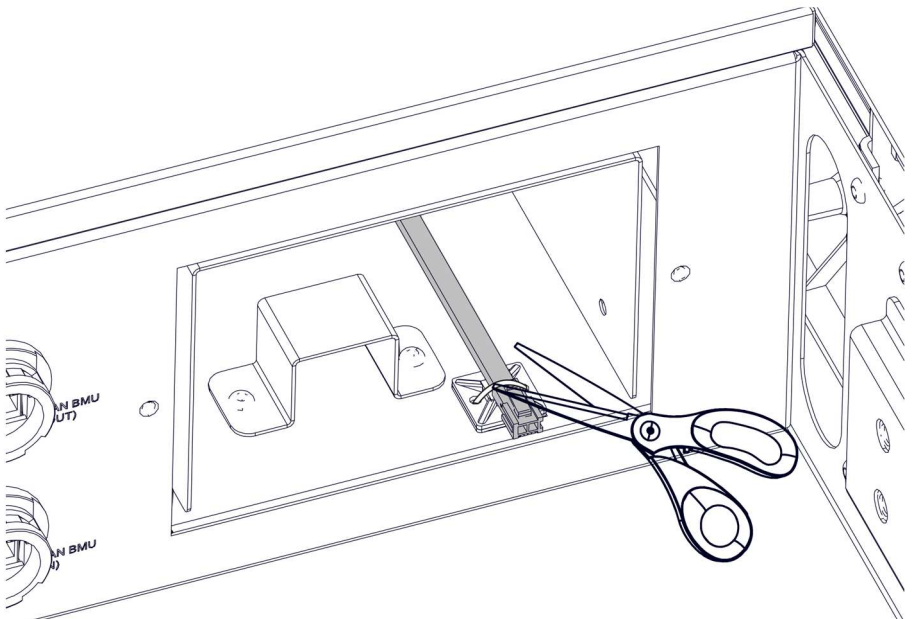



Before installing the Master, check its configuration (see Section 6/page 73).

2

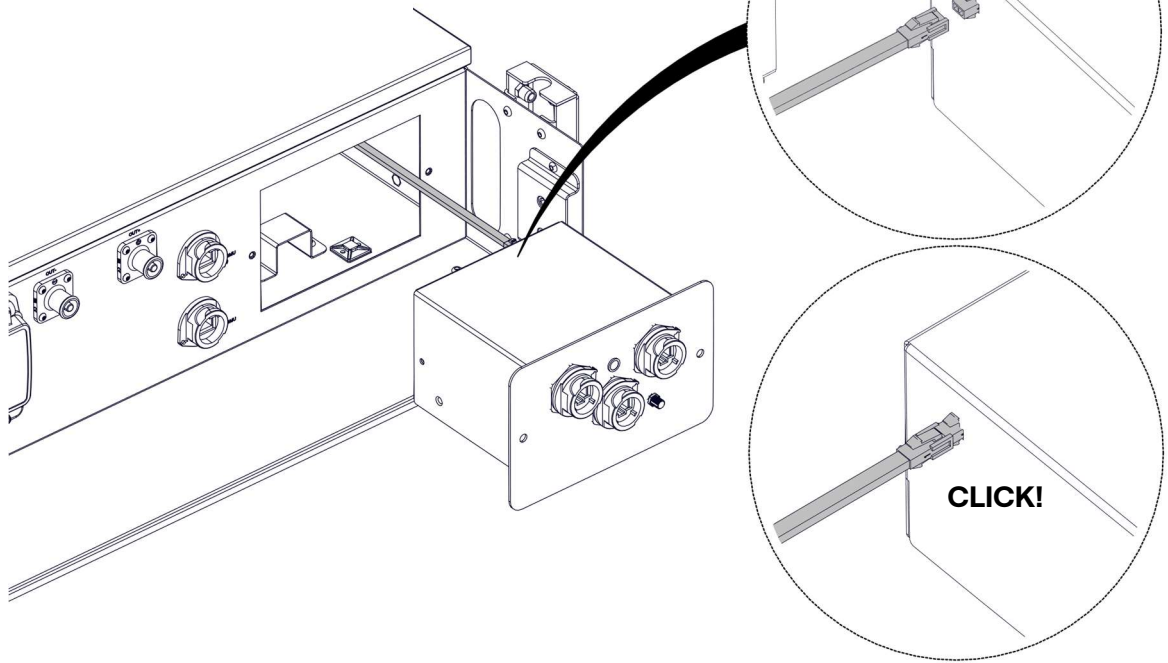

3

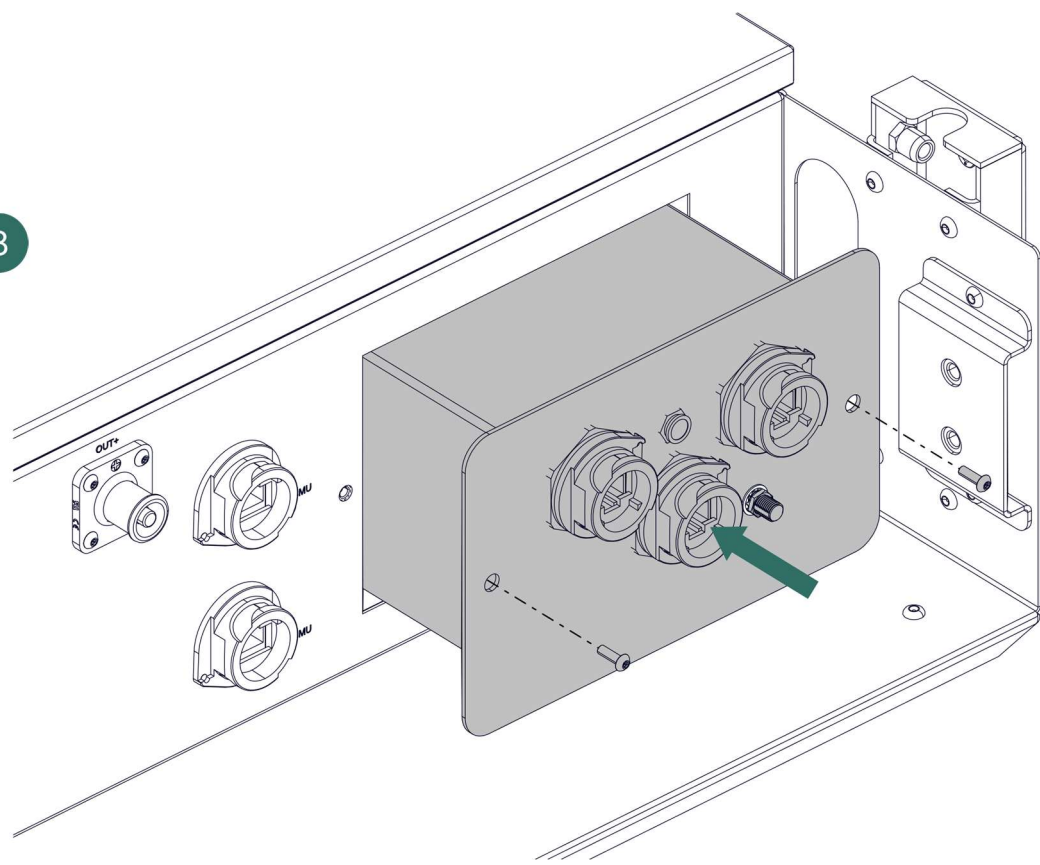

12

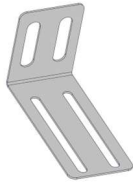

CE7

Wall tie X2



CE4

M6 Screw X4



T11

Torx T30 screwdriver



This step is only necessary if the tower has 5 Modules or more.

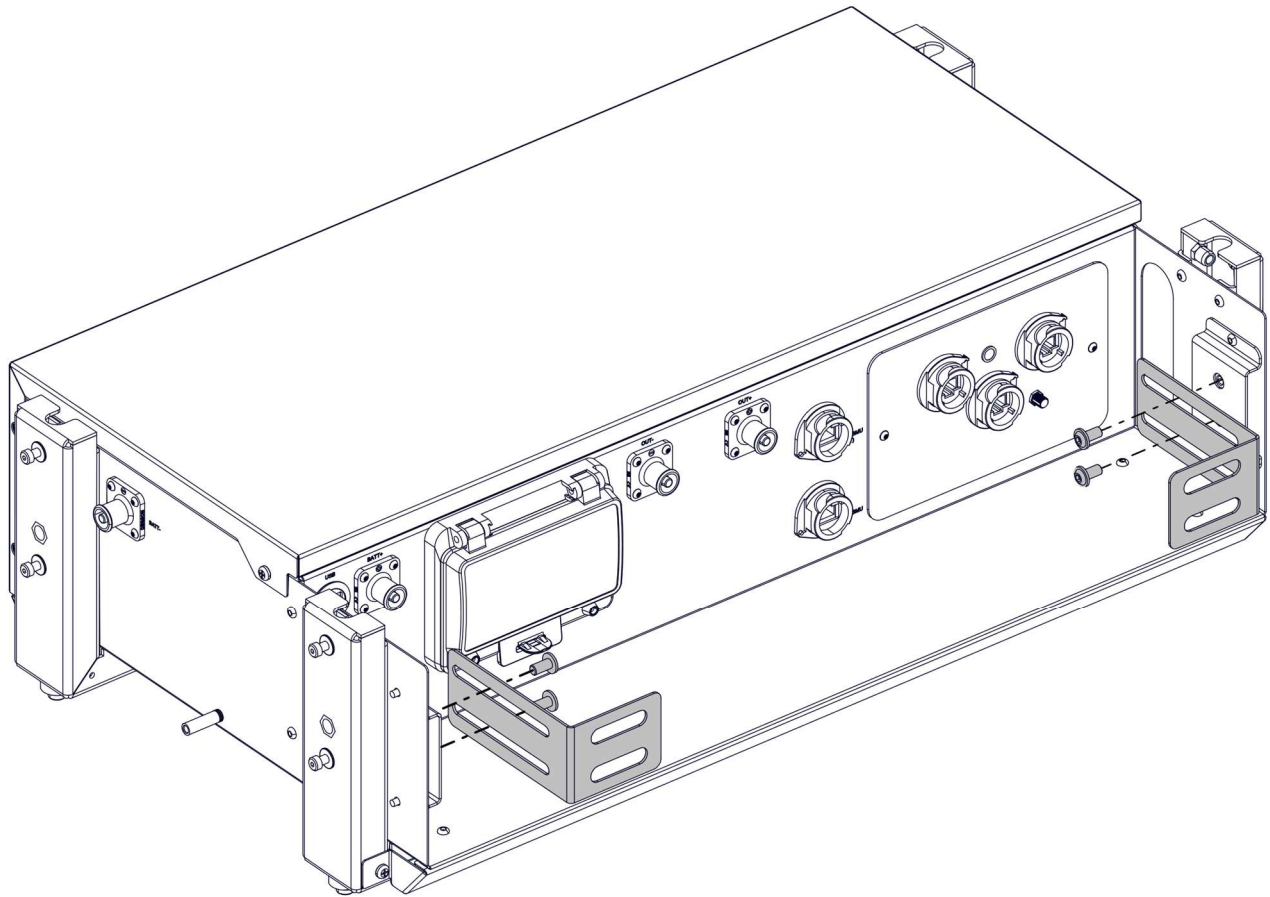

13

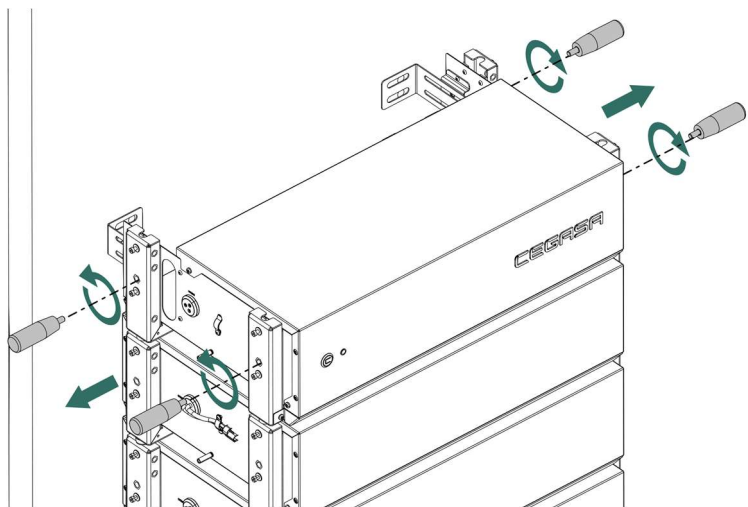
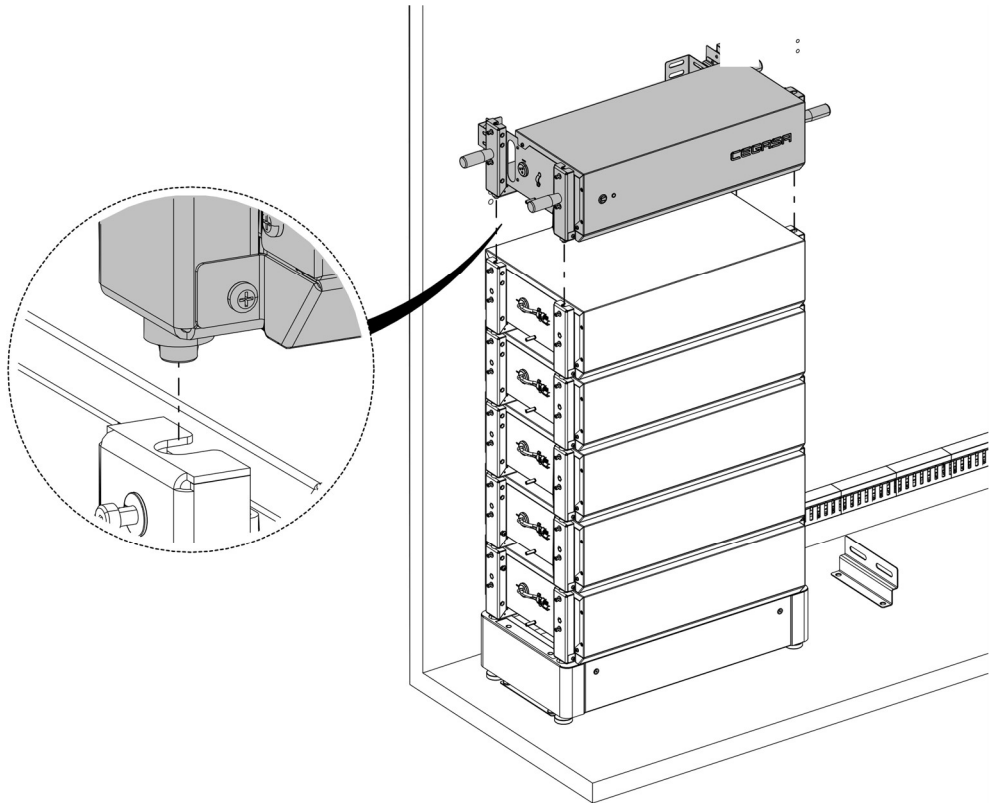
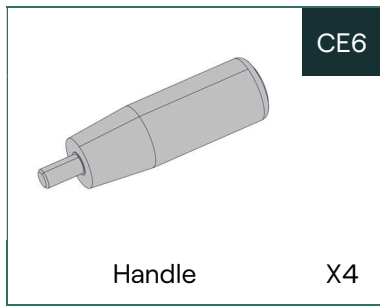
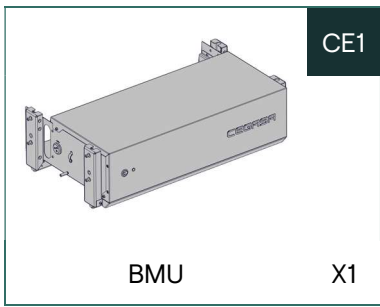

14



This step is only necessary if the tower has 5 Modules or more.



Use of M6x50 lag screws recommended. The plug is to be selected by the installer. Not provided by CEGASA.

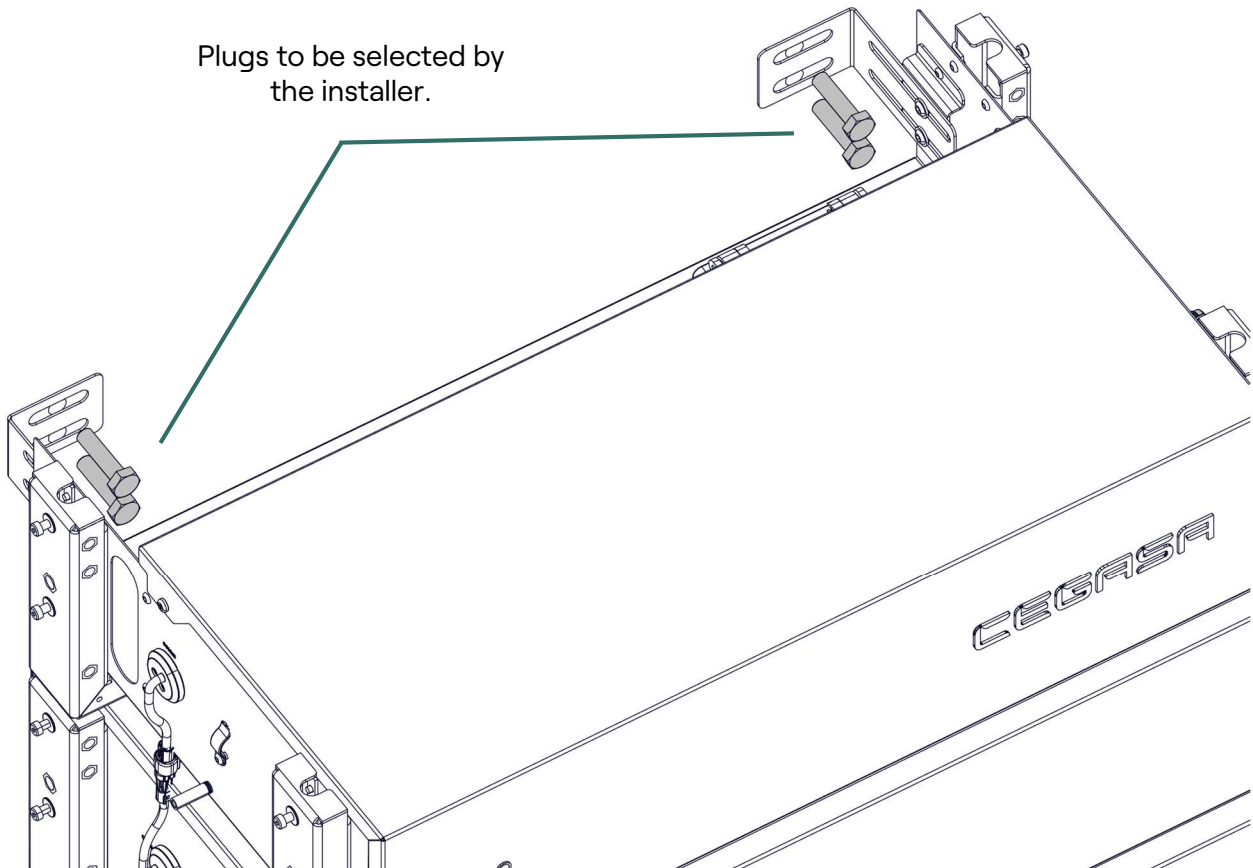

15



CM3

Connection plate

2XN



CM5

M6 Screw

4XN



T11

Torx T30 screwdriver



IMPORTANT: ALWAYS fit the plates. They act as a ground connection between the various modules.

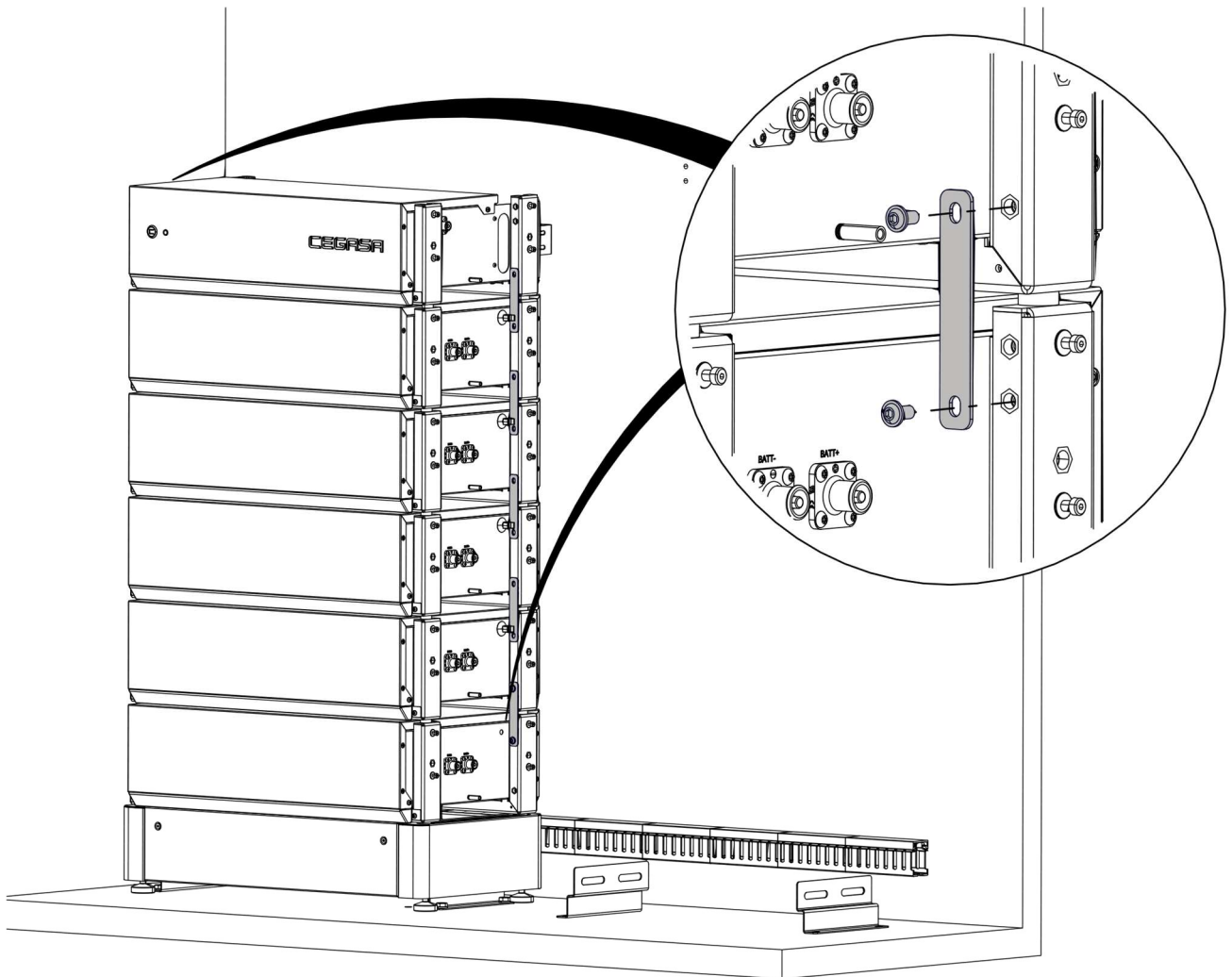

16

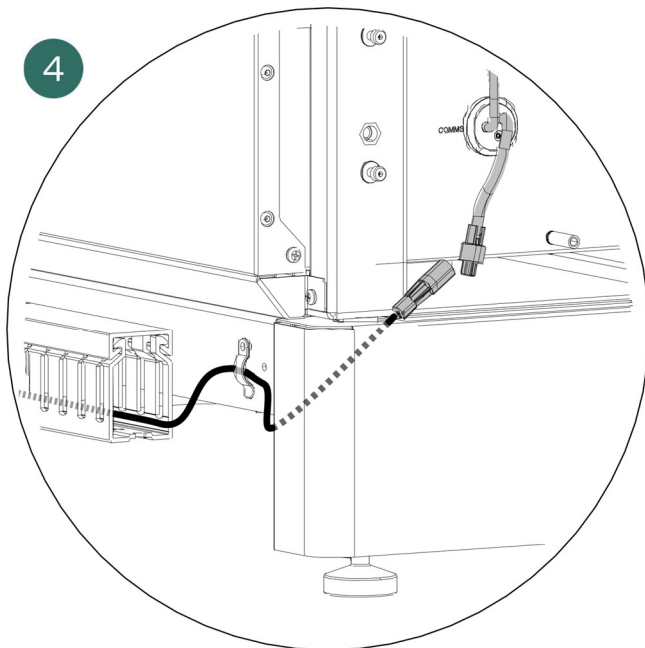
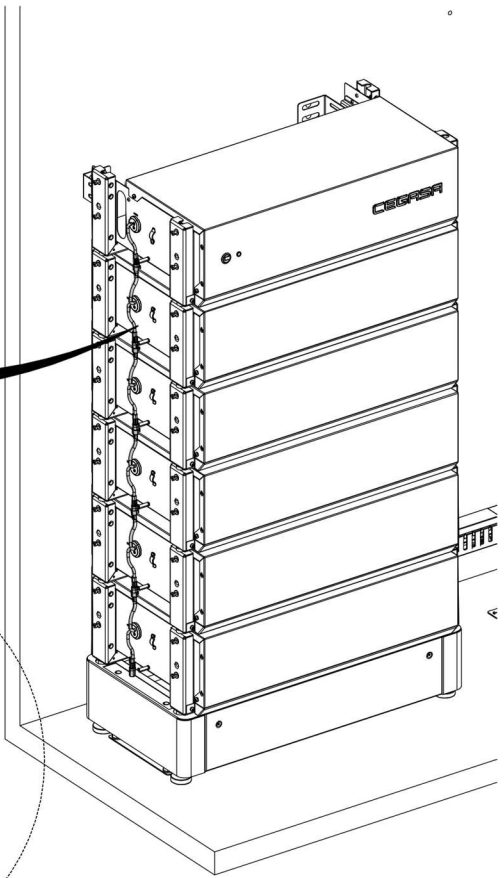
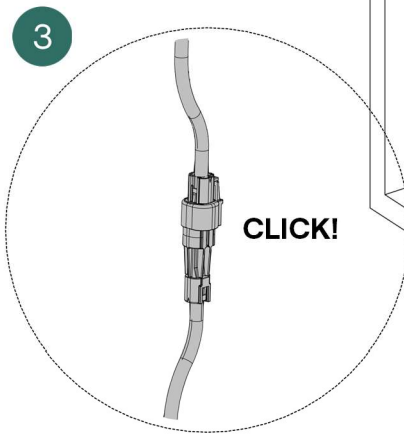
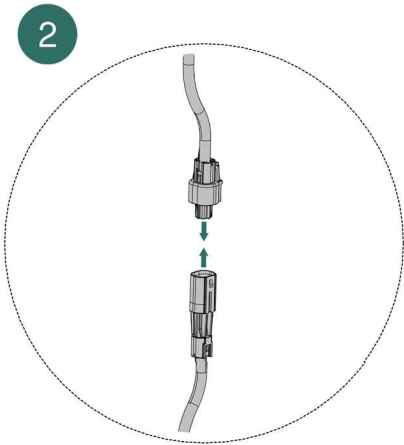
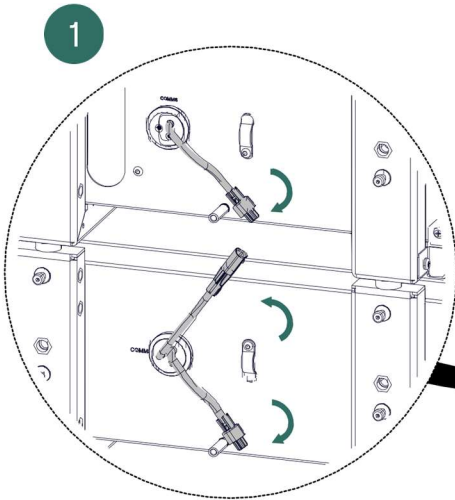

Work downwards on connections from the BMU and gather the cables together into the Module, ensuring they are in a vertical position.



Connect the male COMMS cable of the last Module to the COMMS cable that comes out of the wiring duct inside the base.

17

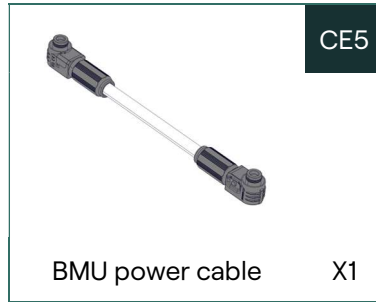
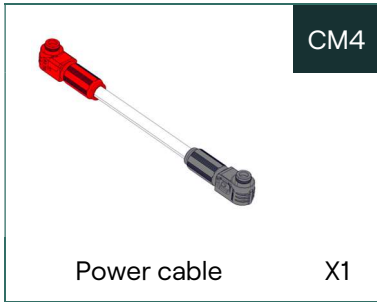

Start the connections from the BMU.



Place the heads with their corresponding connector:

Black = Negative

Red = Positive

1

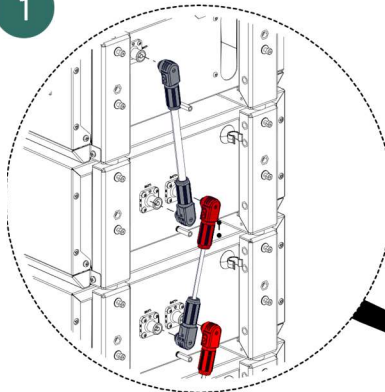

CLICK!

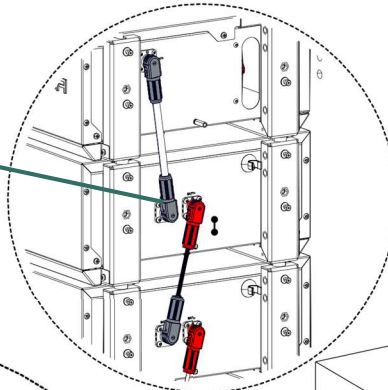

2

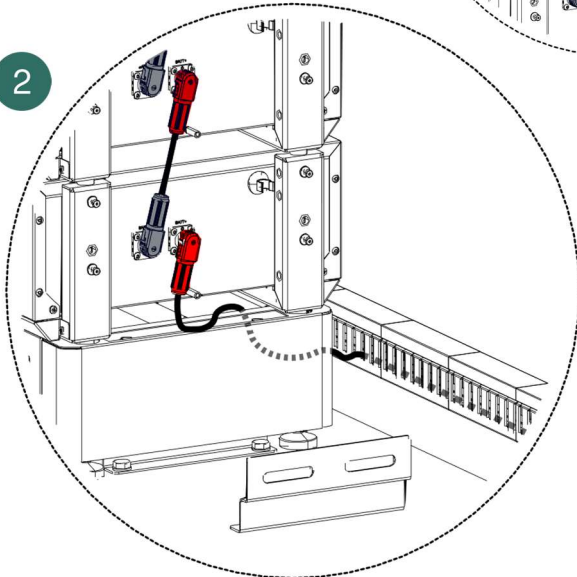

Connect the power cable that comes out of the wiring duct to the positive connector of the last Module inside the base.

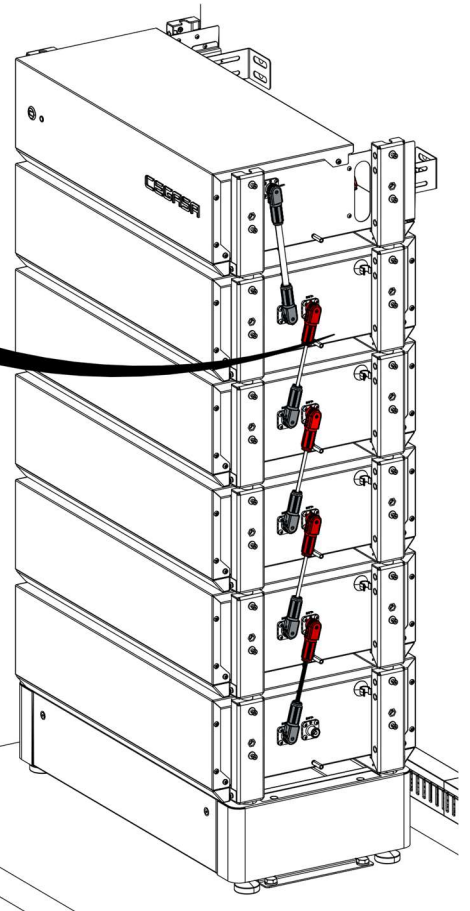

18



CT7

5 m power cable X1

i Pass the cable through the tower guides and wiring duct.

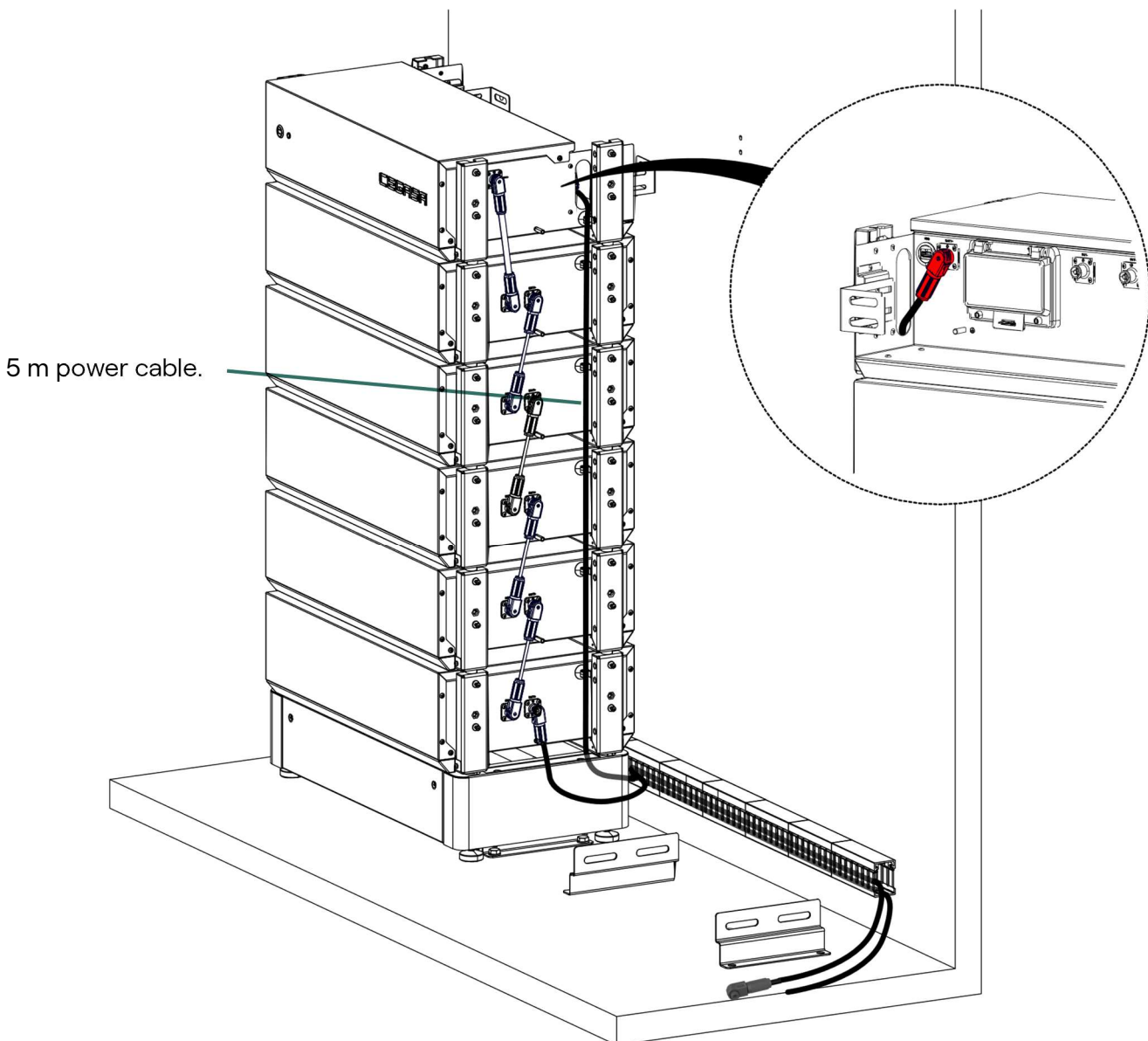

19

- i** Assemble the second Tower outside its final position. Repeat steps 5, 8, 9, 10 and 15.

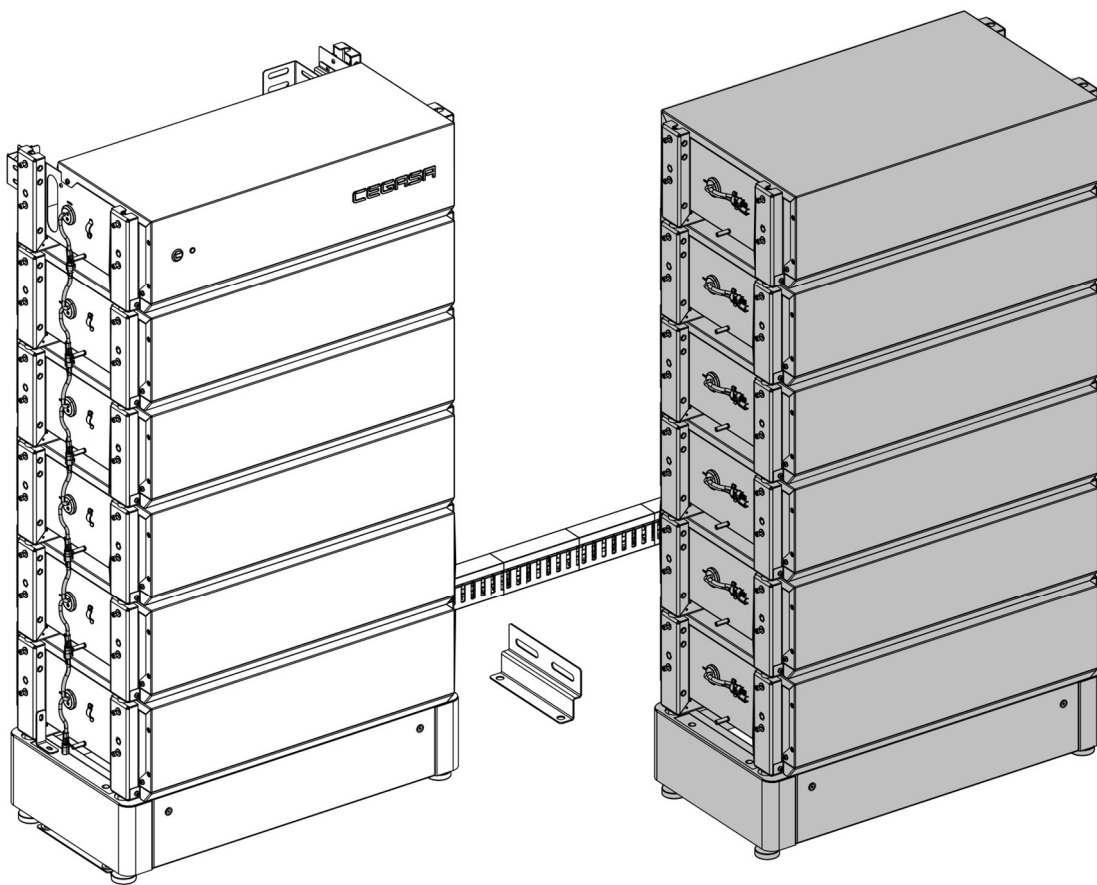

IMPORTANT: ALWAYS fit the plates.
They act as a ground connection
between the various modules.

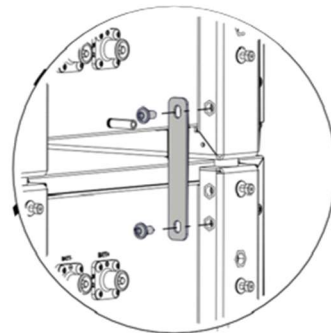

20



Clamp the female connector on the upper unit and the male connector on the lower unit to the clip.



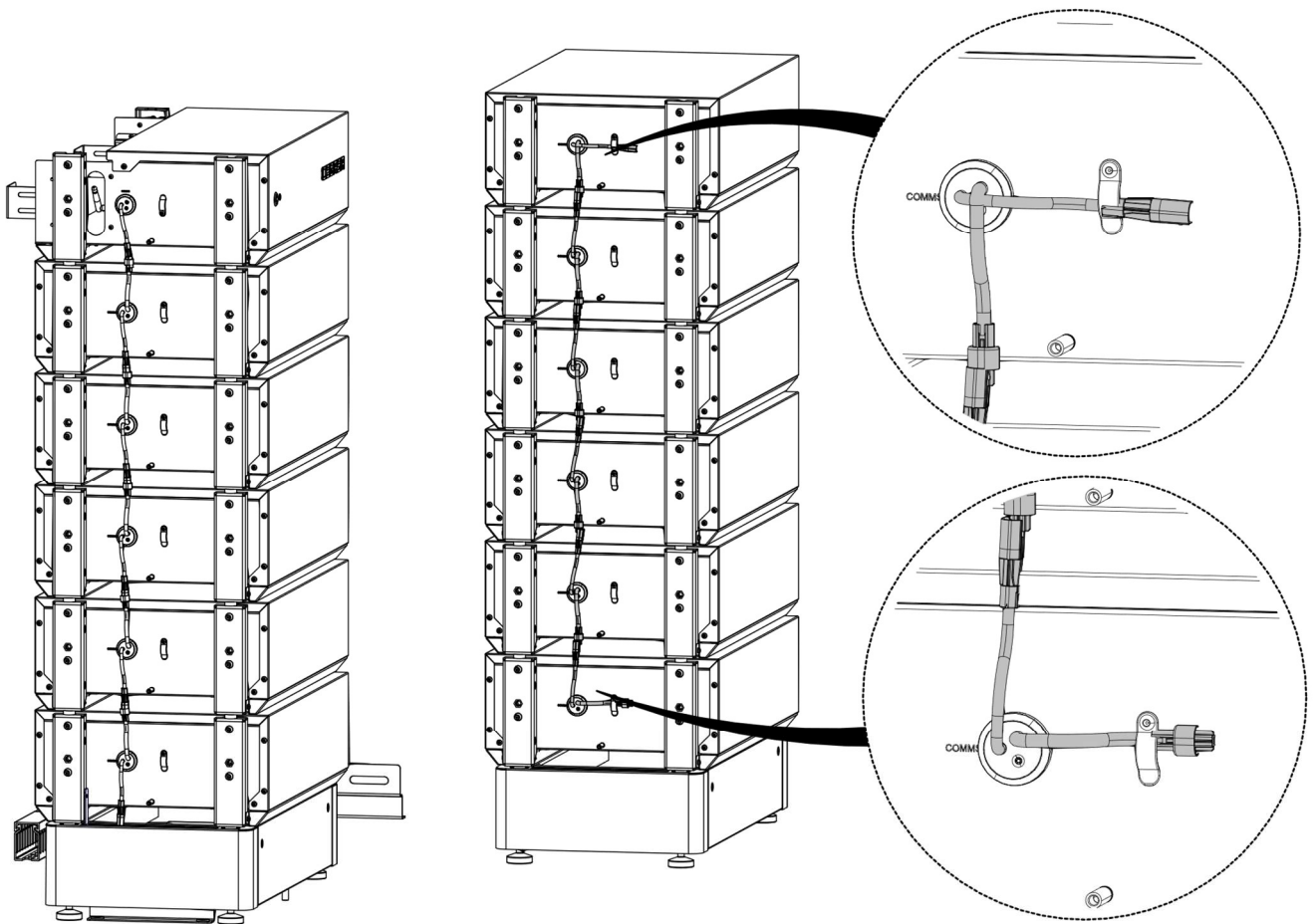

Gather the cables into the Module to ensure that they are in a vertical position.

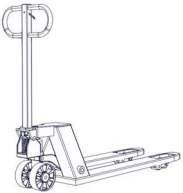

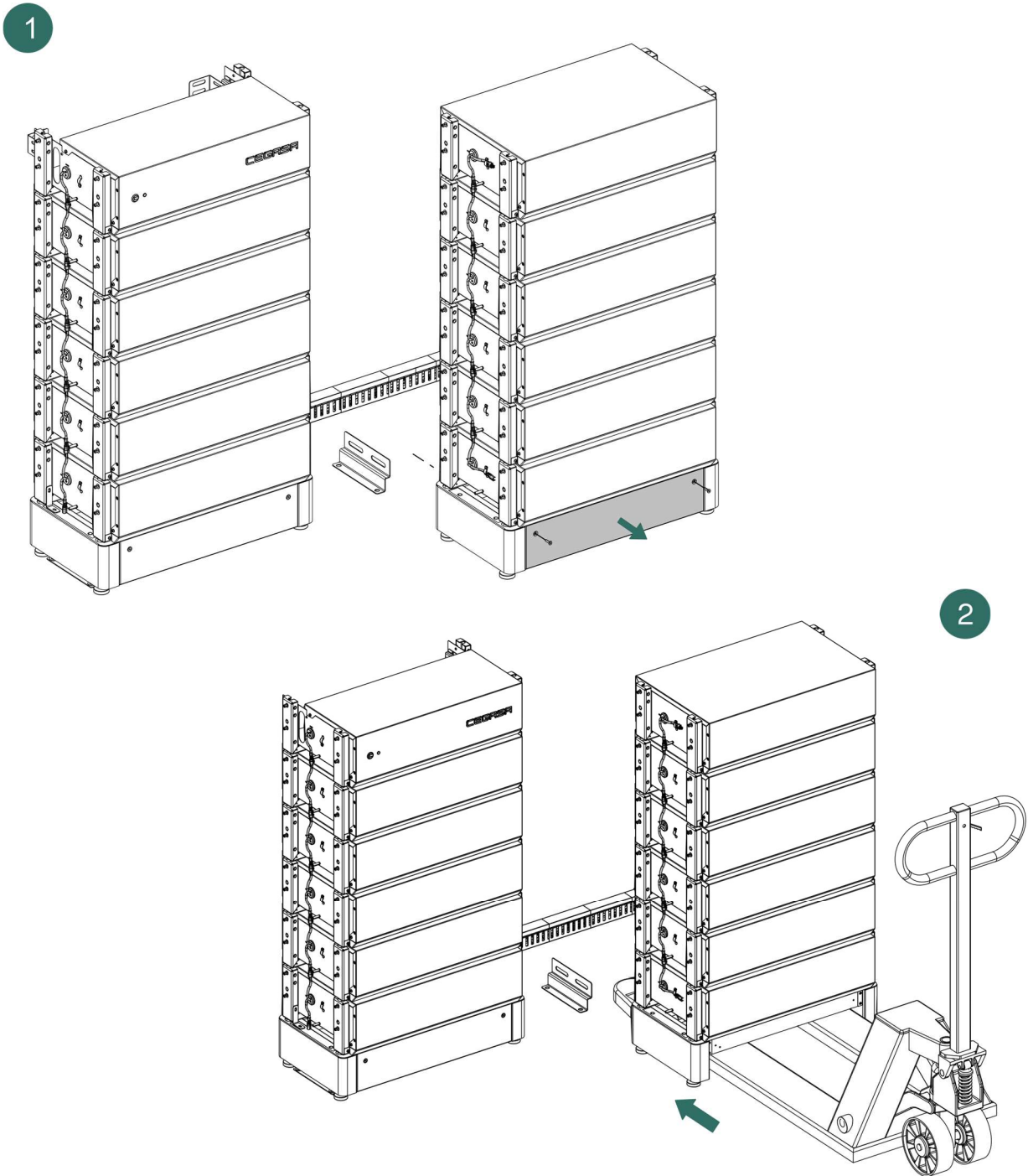
21	 3 Allen key	T5	 Pallet jack	T9
-----------	--	-----------	--	-----------



22	 <p>CP6</p>	 <p>T12</p>
	M8 Screw X2	Torx T35 screwdriver

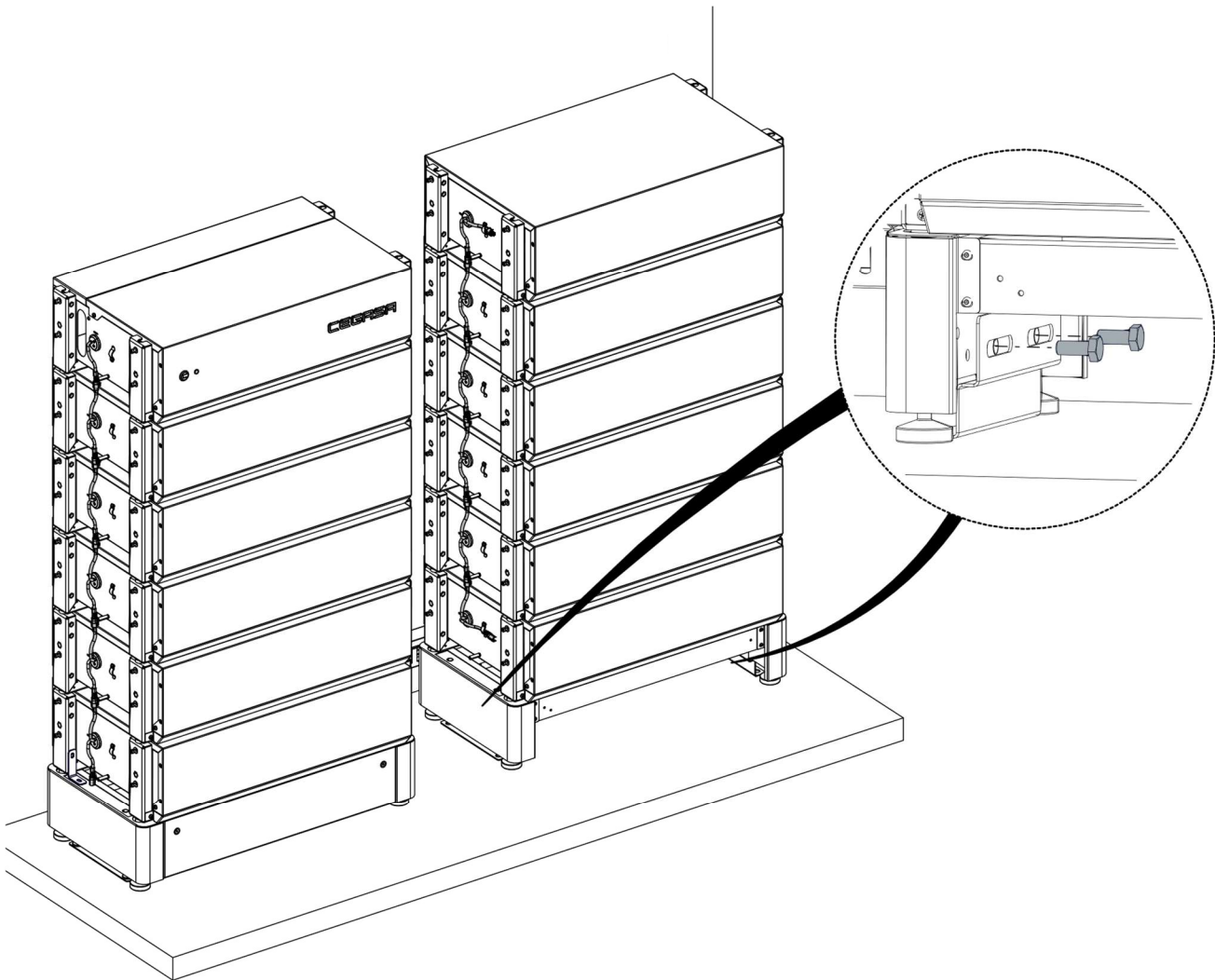

23



CT1

Wall-battery tie

X2

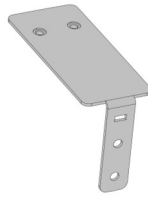

CT2

Wall-battery tie

X2



CT5

M6 Screw

X8



T11

Torx T30 screwdriver

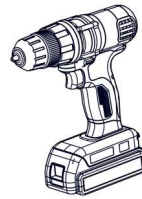

T1

Drill



This step is only necessary if the tower has 5 Modules or more.

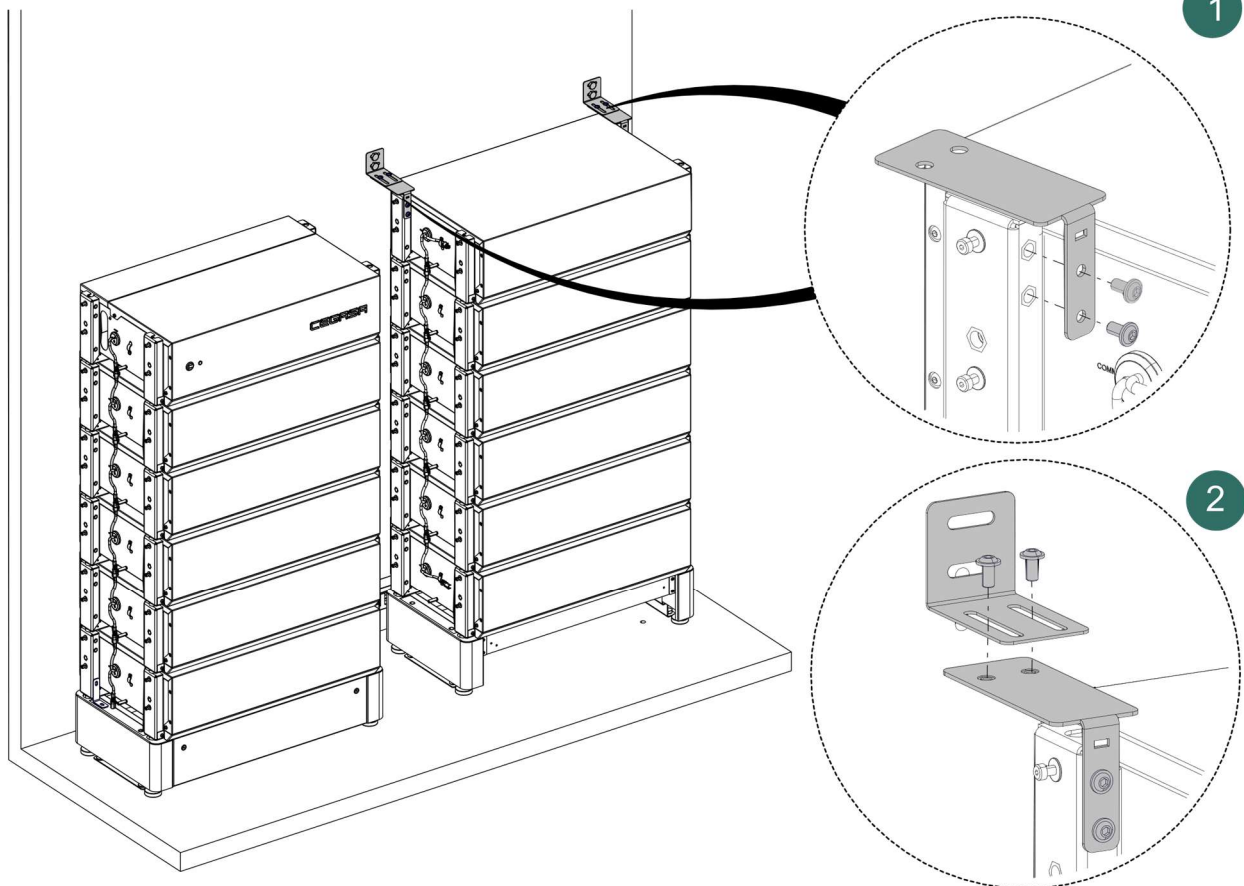

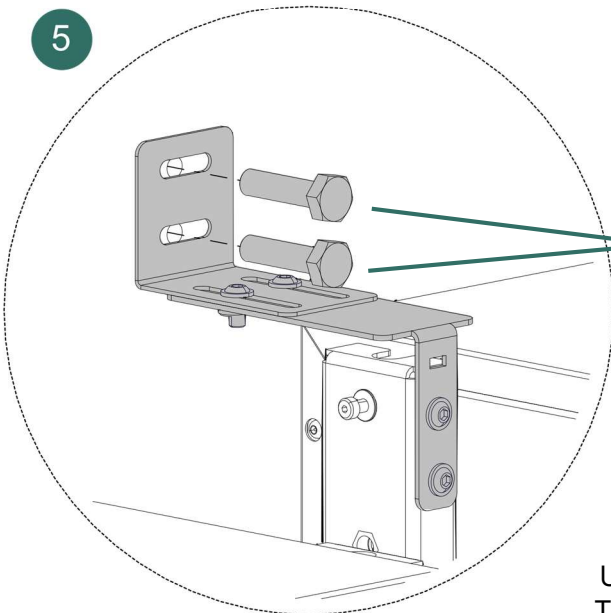
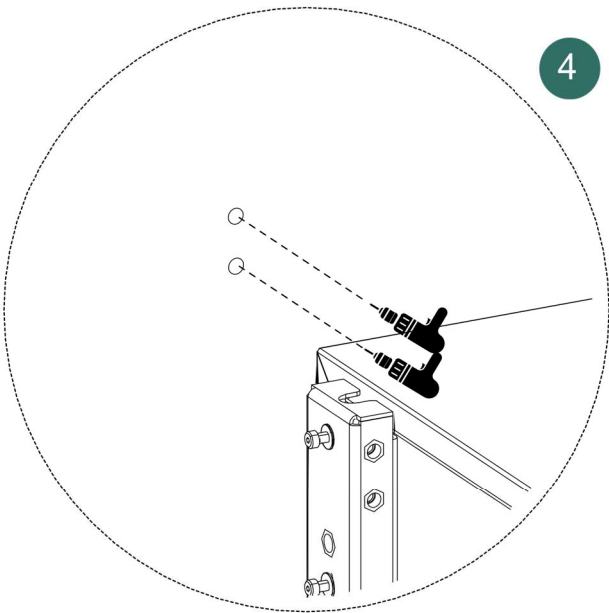
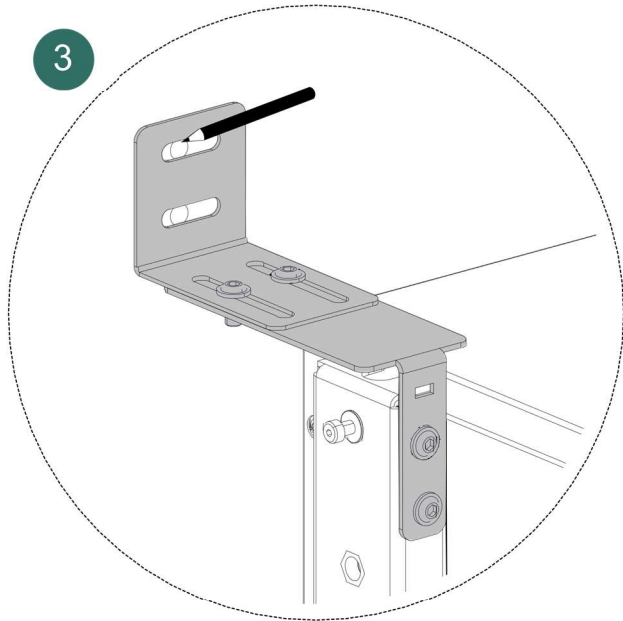

Plugs to be selected by the installer.

Use of M6x50 lag screws recommended.
The plug is to be selected by the installer.
Not provided by CEGASA.



24

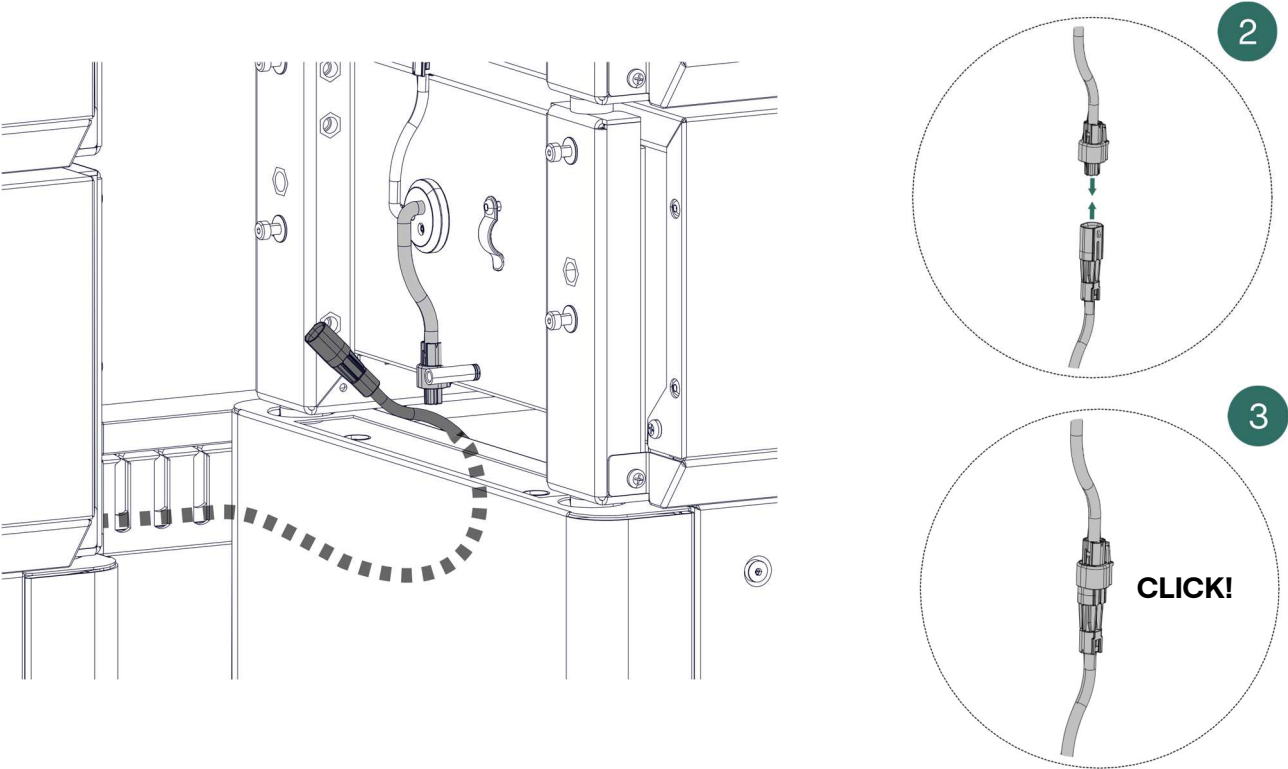
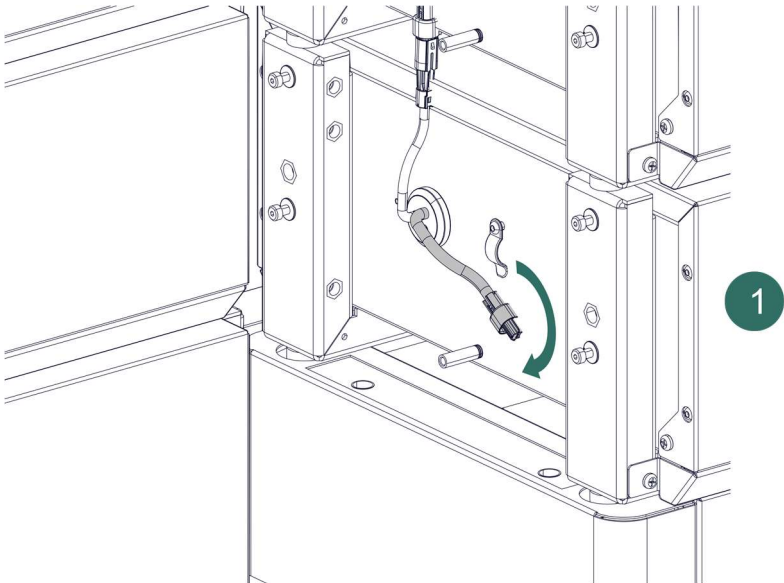

25

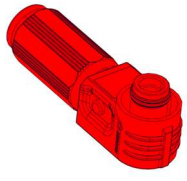

CE8

Female positive power connector X1

T6

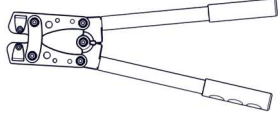

Crimper X1



Ensure that the **2 m power cable** is not connected to the Module before carrying out the following actions.



Take the measurement when the cable is correctly placed.

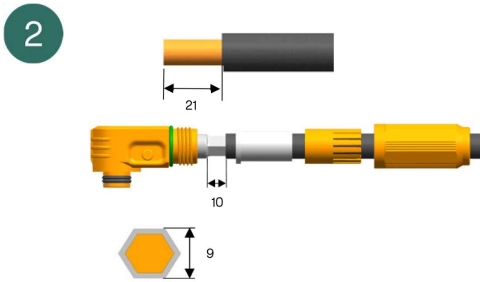

Crimp the positive aerial connector 21 mm (± 1).



Check that the cable is well crimped. If in doubt, contact CEGASA.

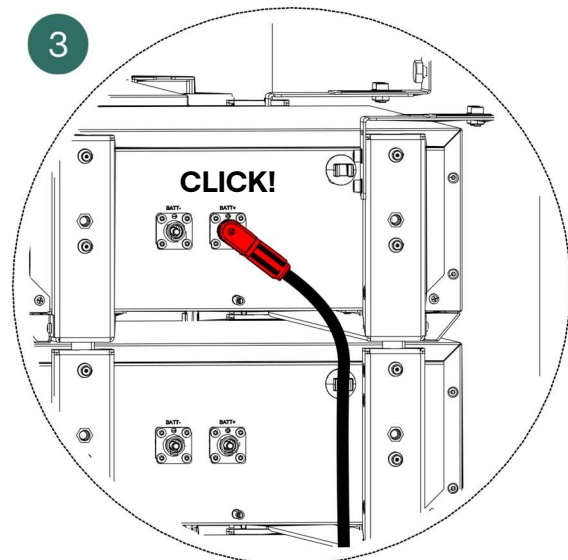
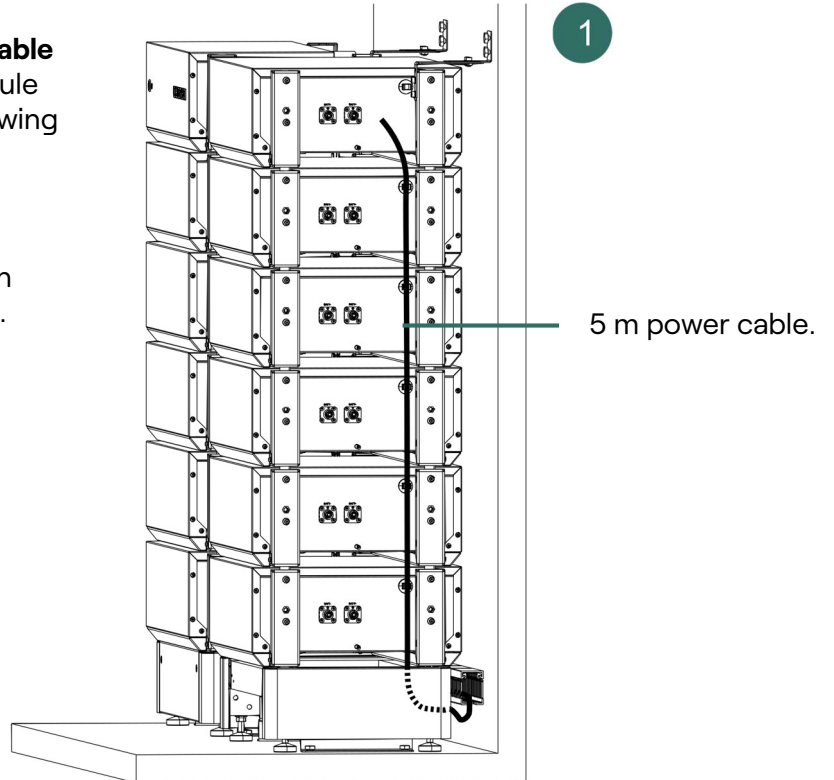

26

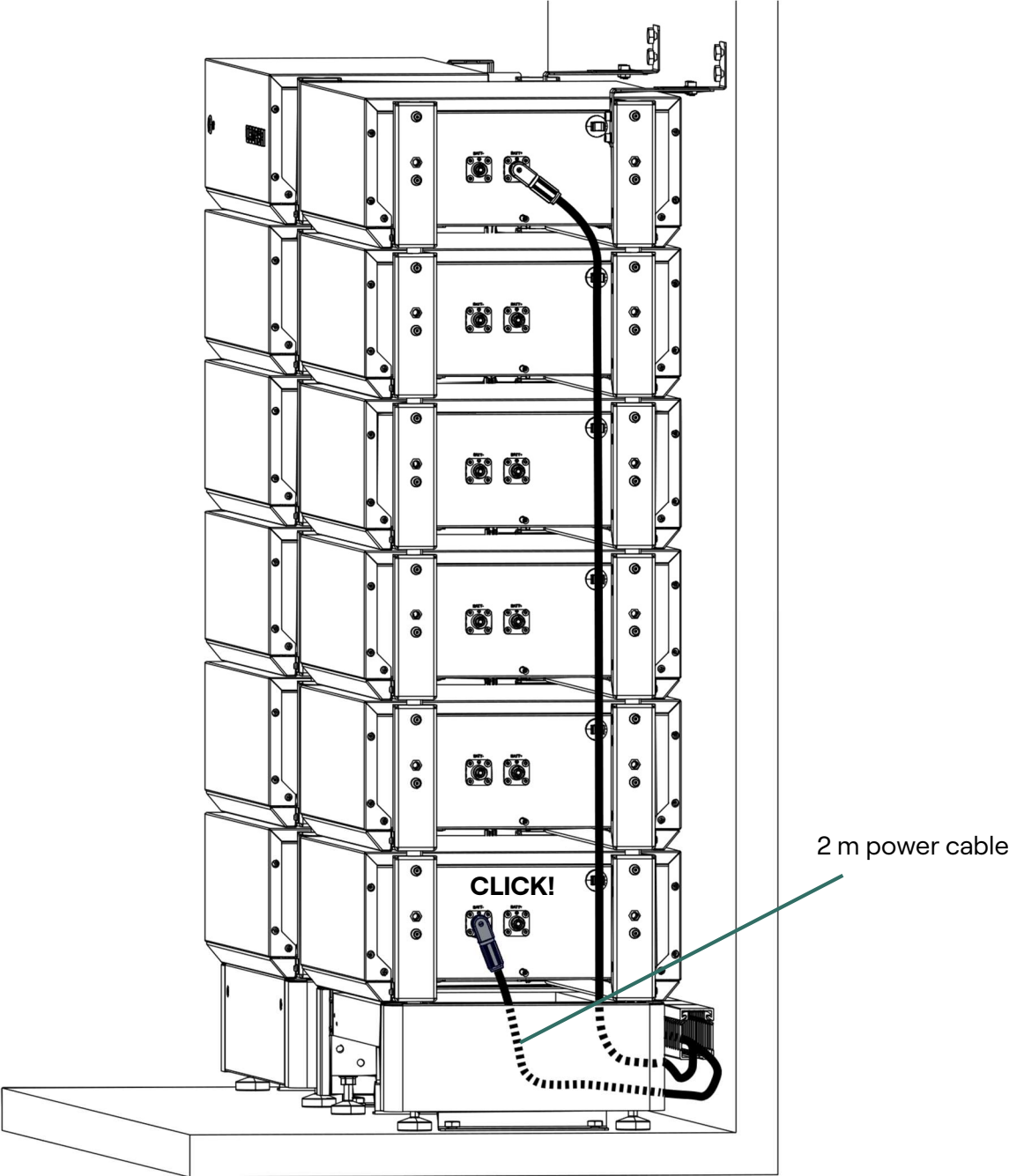

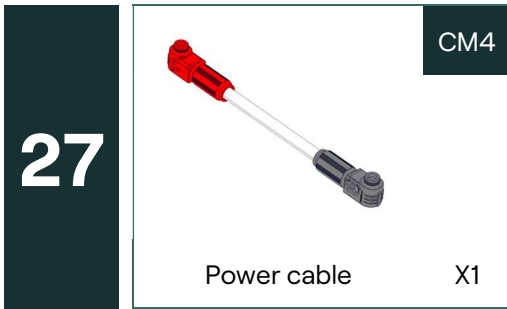

i Place the heads with their corresponding connector.
Black = Negative
Red = Positive

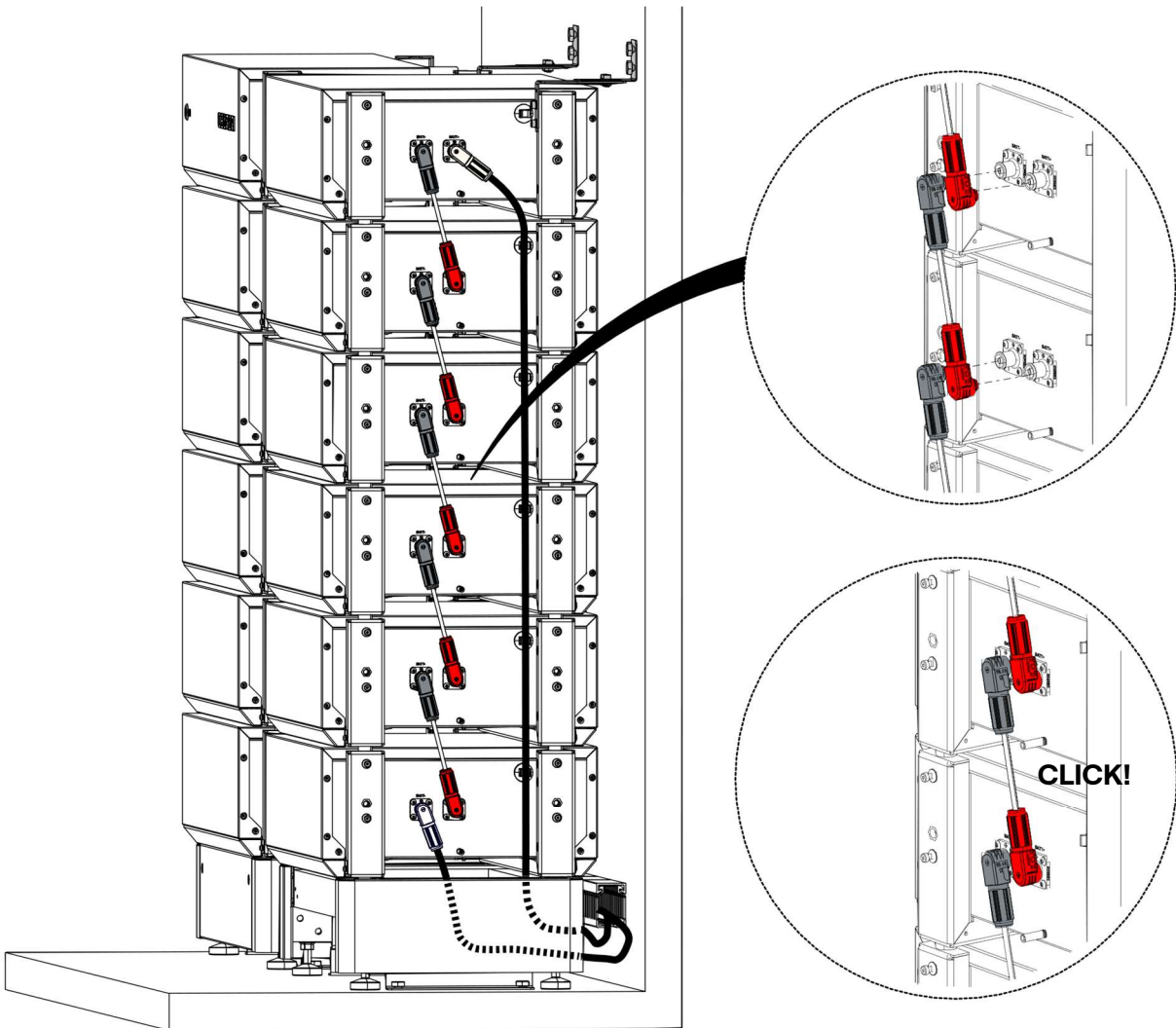

28

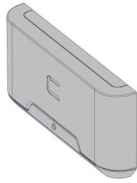

CE2

BMU side cover

X2

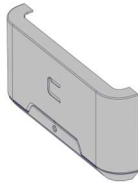

CM2

Module side cover

2xN



T3

2.5 Allen key

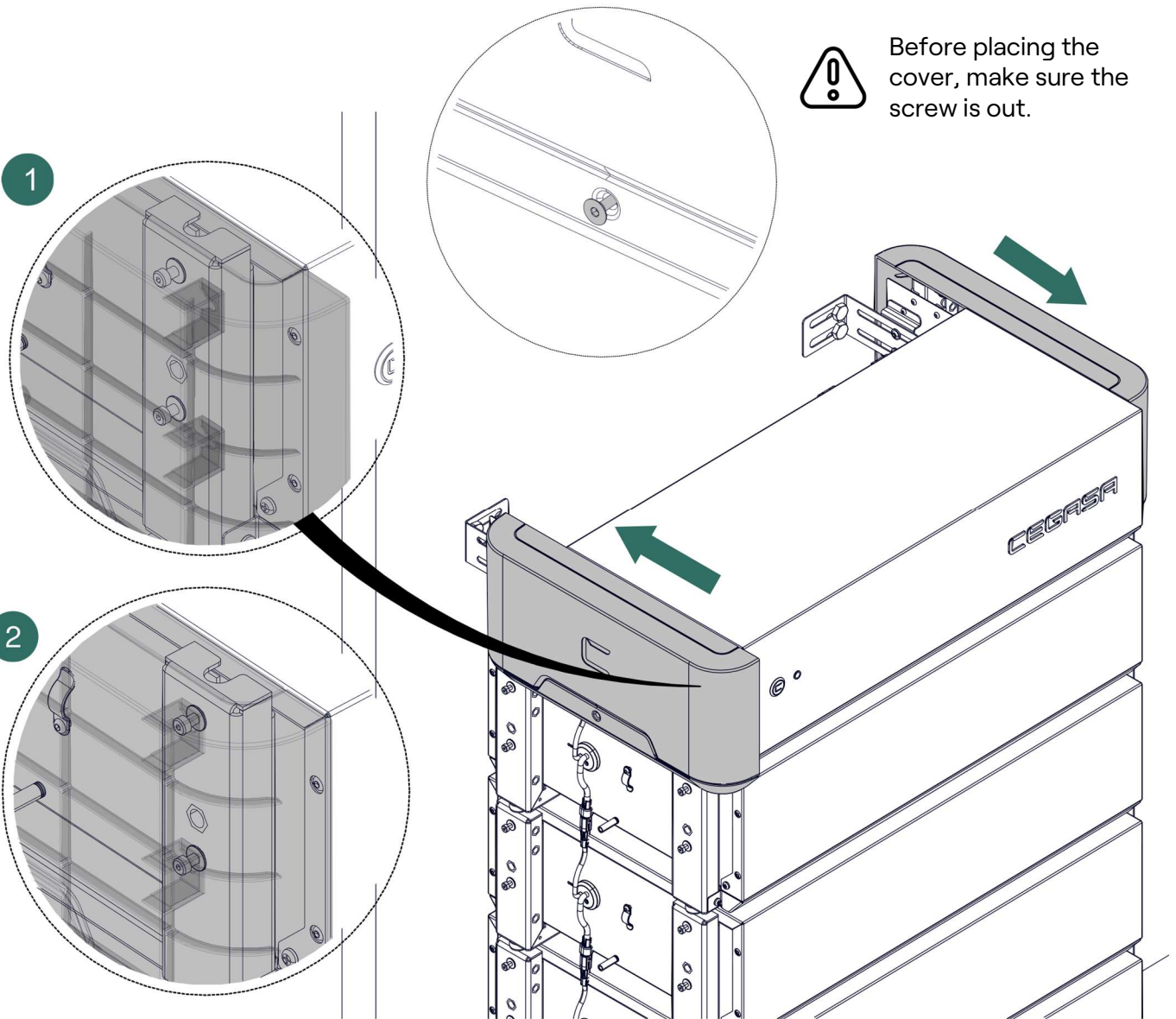

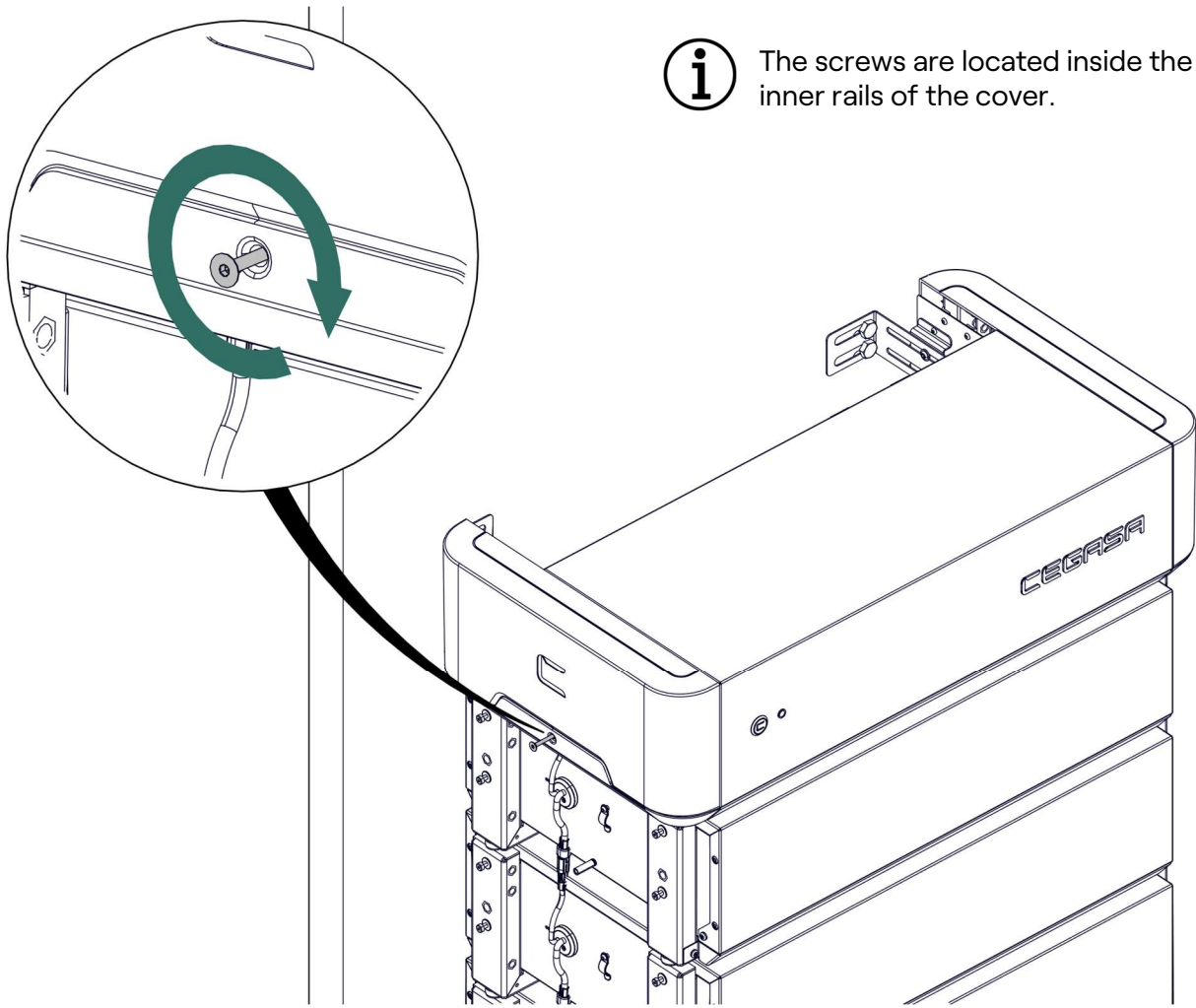

i The screws are located inside the inner rails of the cover.

Set the remaining covers in the same way.

i

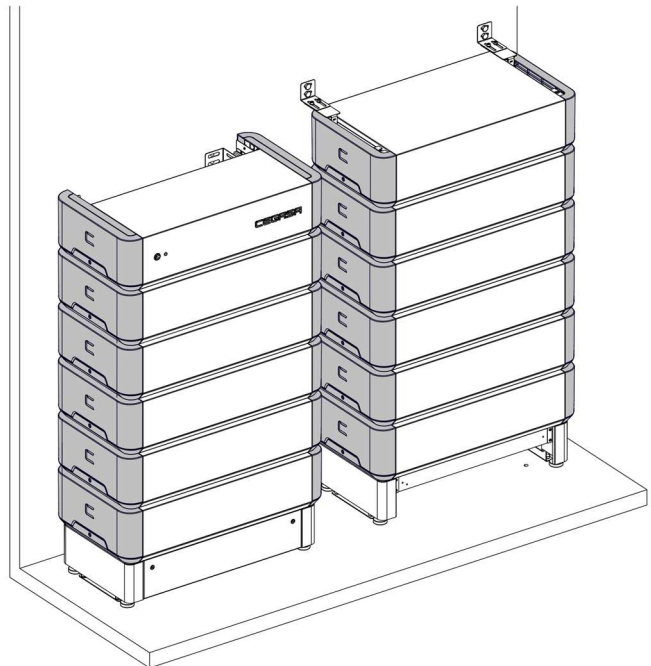

29

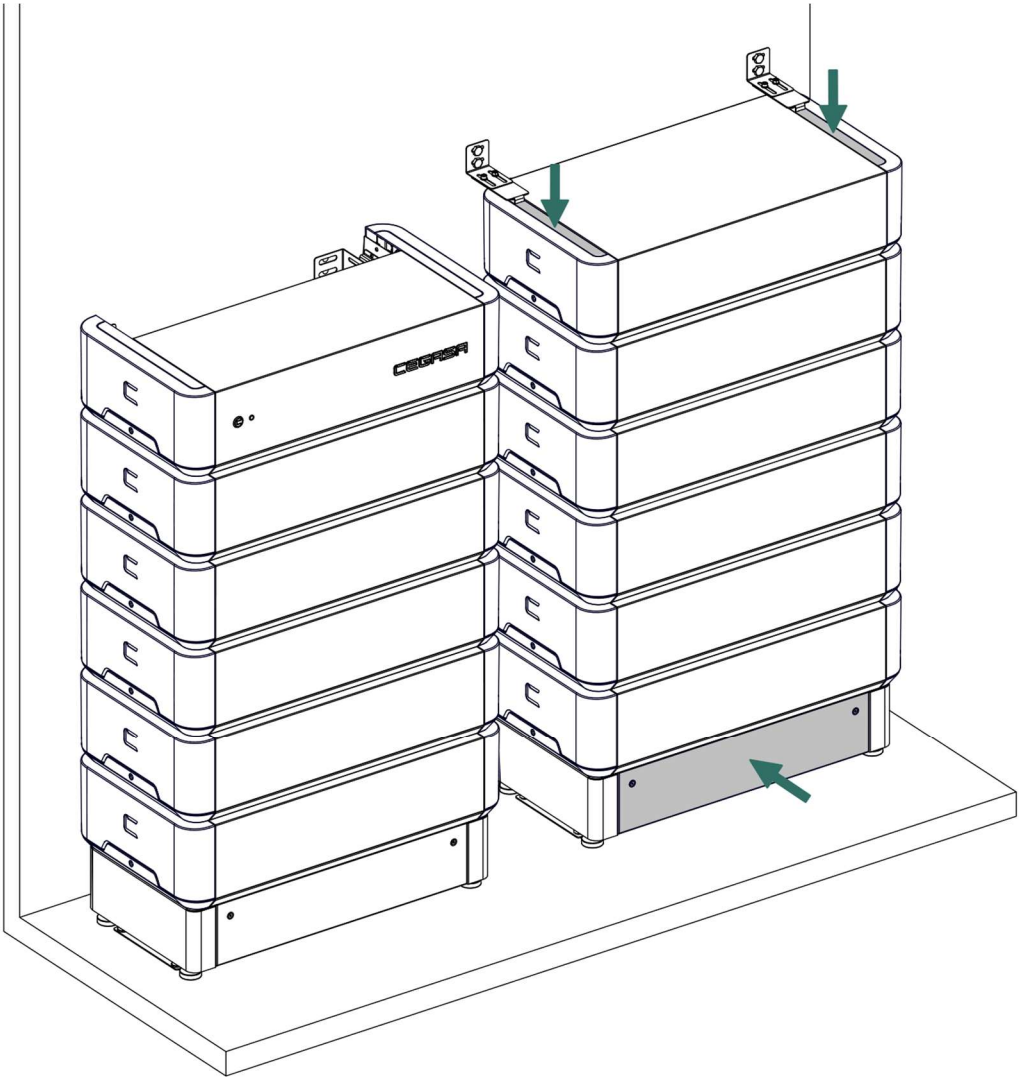
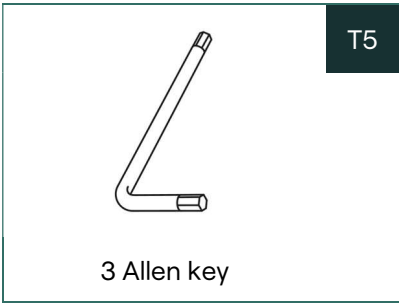

5 CONNECTIONS

5.1 CONNECTING A STRING

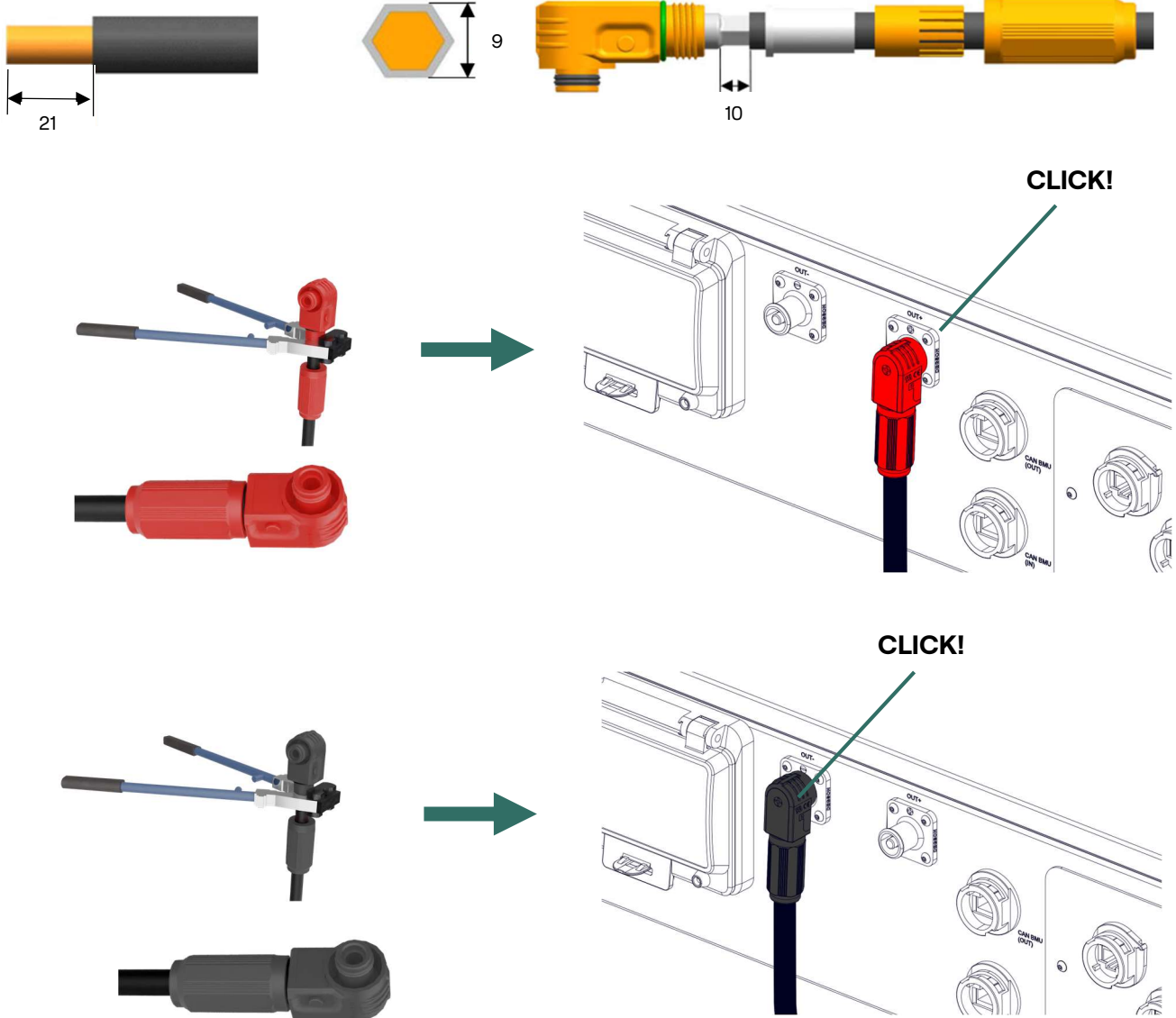

ITEM	TYPE OF CABLE	FEATURES
1	Inverter positive cable	1000 Vdc cable with 25 mm ² section (not included).
2	Inverter negative cable	1000 Vdc cable with 25 mm ² section (not included).
3	Inverter COMMS cable	Cat5e (min.) UTP cable, standard parallel (not included).
4	Earth cables	Earth cable with 10 mm ² section (not included).

Before connecting, ensure that the main switch is down.

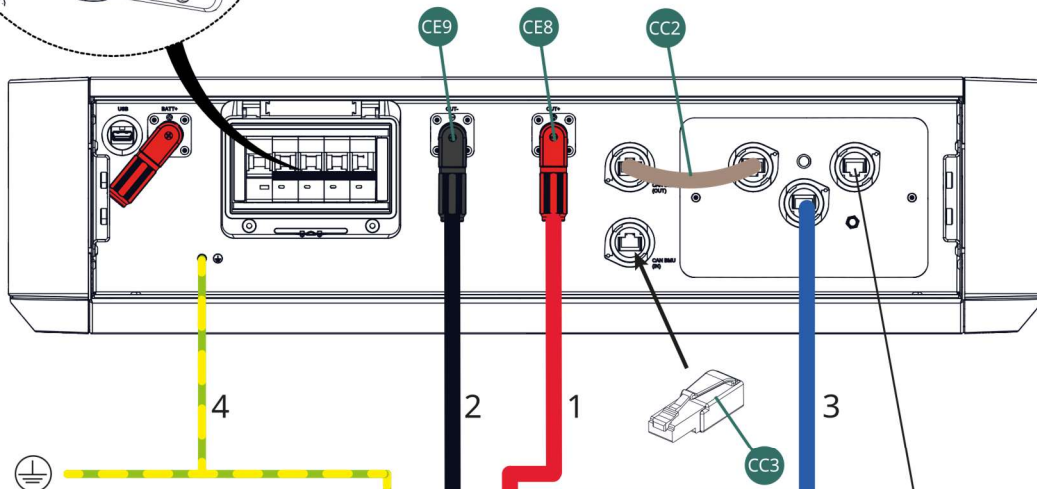
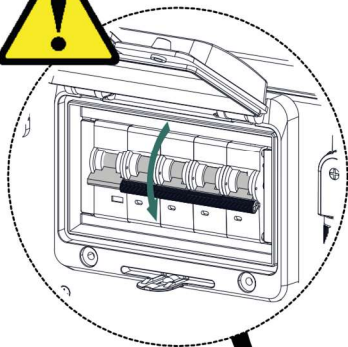

Make sure to always have the BMU connected to the earth.

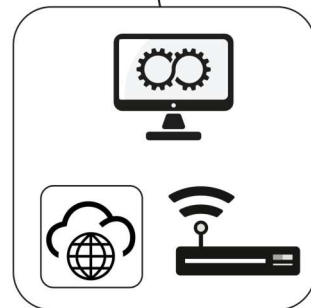

The second tower must be connected to earth from the indicated point, as the last screw does not have a bolt for this terminal.

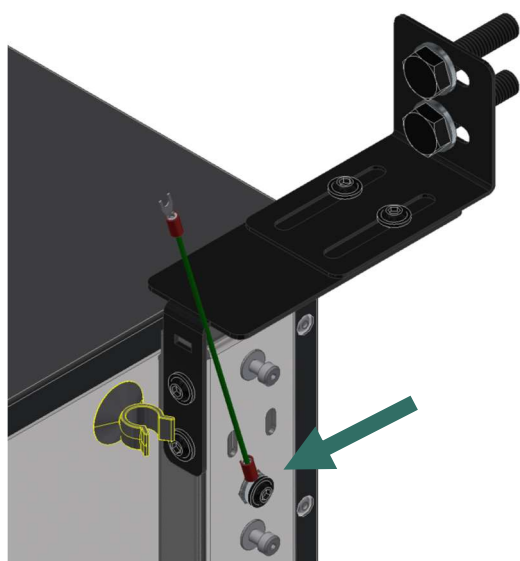
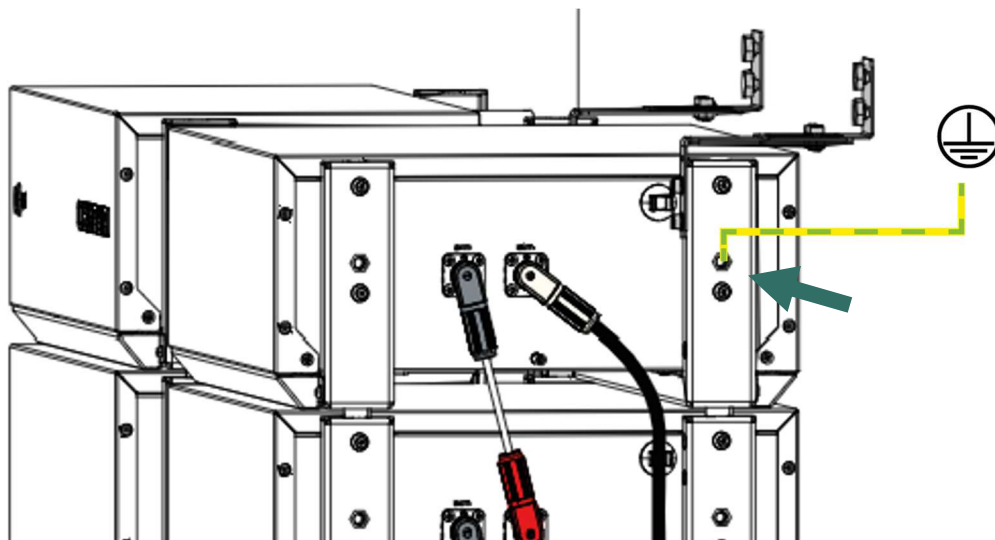

Attach to the riveted nut used to fit the handles.
*Screws not provided by CEGASA

5.2 CONNECTING SEVERAL STRINGS (UP TO 4)

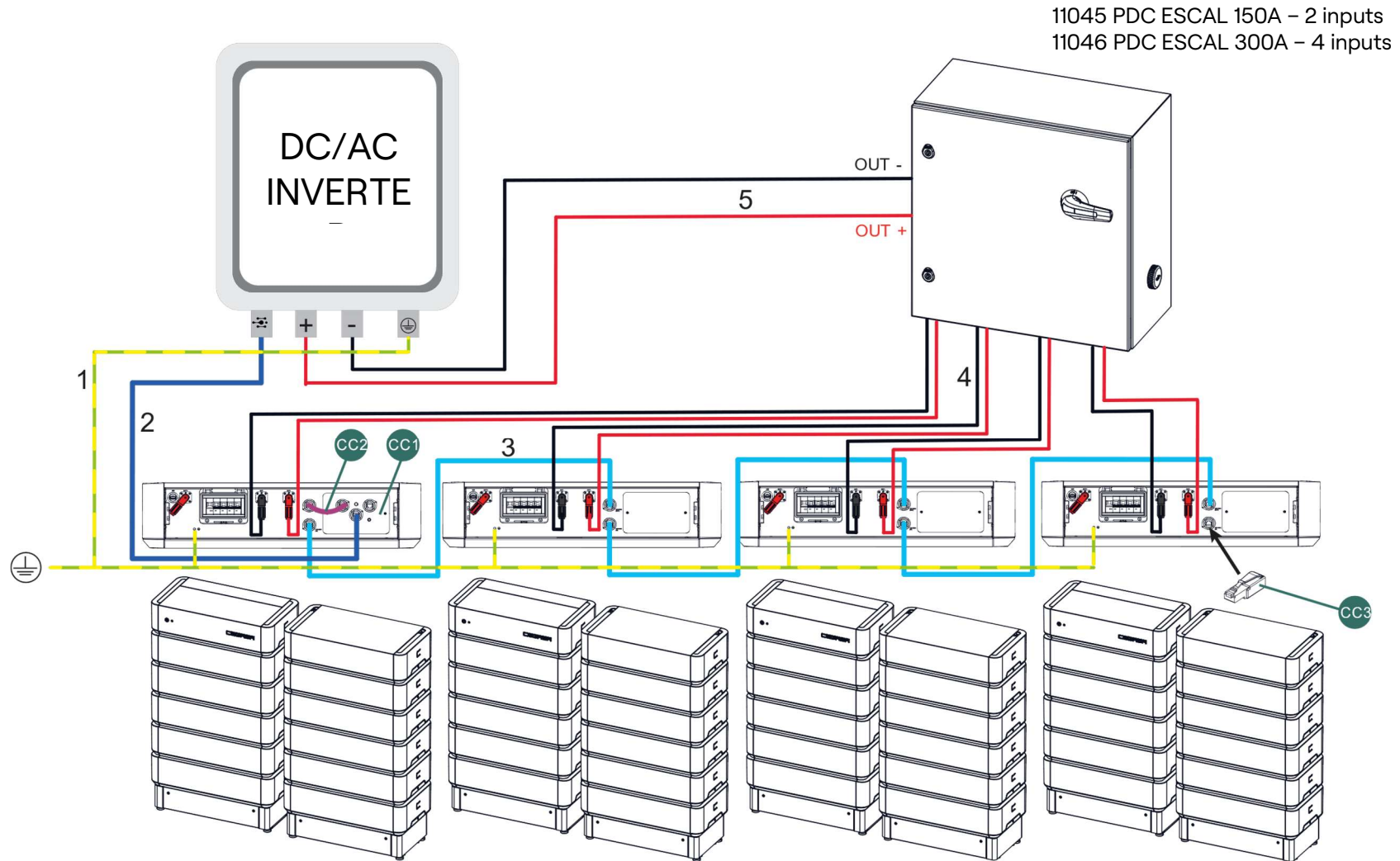

5.3 CONFIGURATION OF MASTER MCS COMMUNICATIONS

ITEM	TYPE OF CABLE	FEATURES
1	Earth cable	Earth cable with 10 mm ² section (not included).
2	COMMS cable to the inverter	Cat5e (min.) UTP network cable, standard parallel (not included).
3	COMMS cable between EScal BMU	Cat5e (min.) UTP network cable, standard parallel (not included).
4	EScal BMU output power cables	1000 Vdc cable with 25 mm ² section (not included).
5	Power cables to the inverter	Consult the number of inputs of the inverter system and the characteristics of the cable in its manual.

6 CONFIGURATION OF THE MASTER MCS UNIT

The unit must be configured according to the communication protocol with the inverter it is going to work with. There are two possibilities depending on the communication protocol with the inverter.

6.1 MODBUS TCP/IP COMMUNICATION PROTOCOL

The factory settings of the unit are valid. No action is required.

6.2 CAN BUS COMMUNICATION PROTOCOL

The unit is configured at CEGASA to work using this communication protocol with the following inverters:

- ✓ **Solis S6-EH3P**
- ✓ **Solinteg-MHT**
- ✓ **Ingeteam Sun Storage 3Play 100TL**

SIGNAL	PIN
CAN_H	4
CAN_L	5

With any other inverter in which the communication protocol is via CAN bus, it will be necessary to modify the "pinout" of the card as follows:

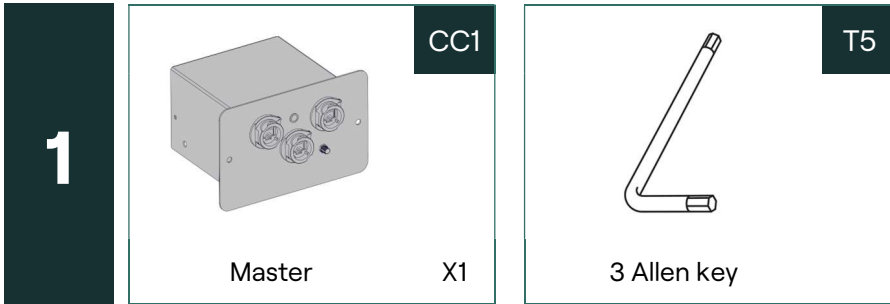

i Open the unit by loosening the four screws on the sides and carefully separating the cover. Remember that the card is connected to the cover.

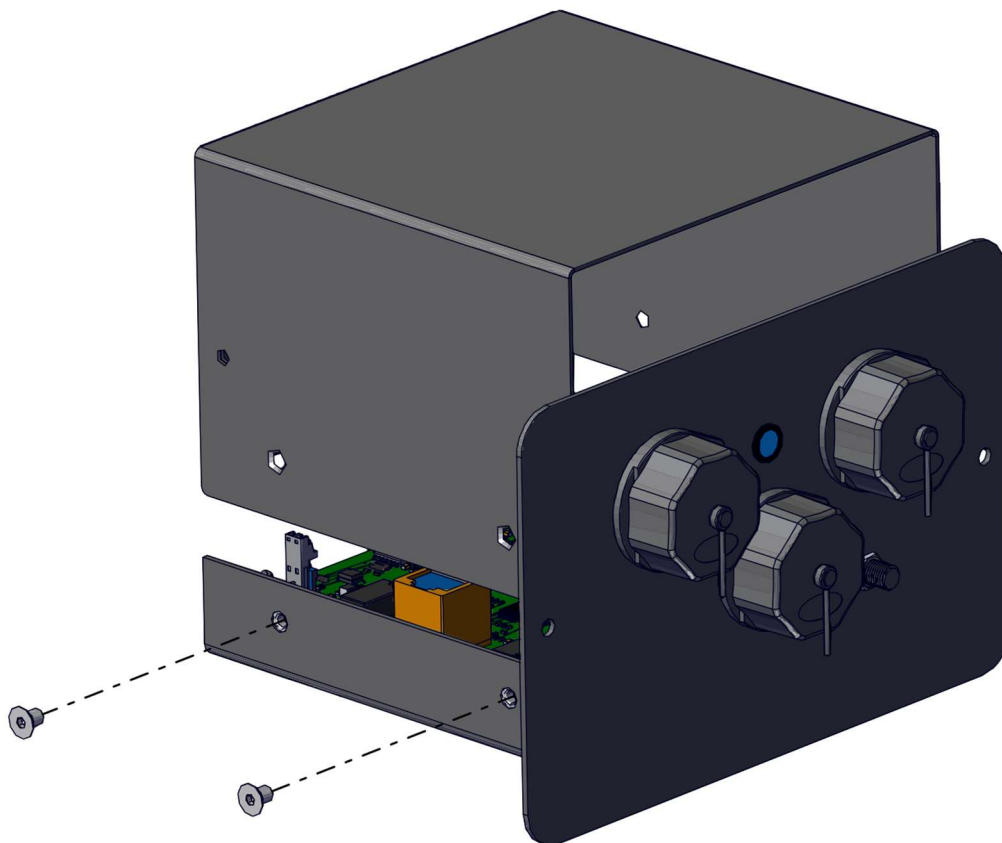

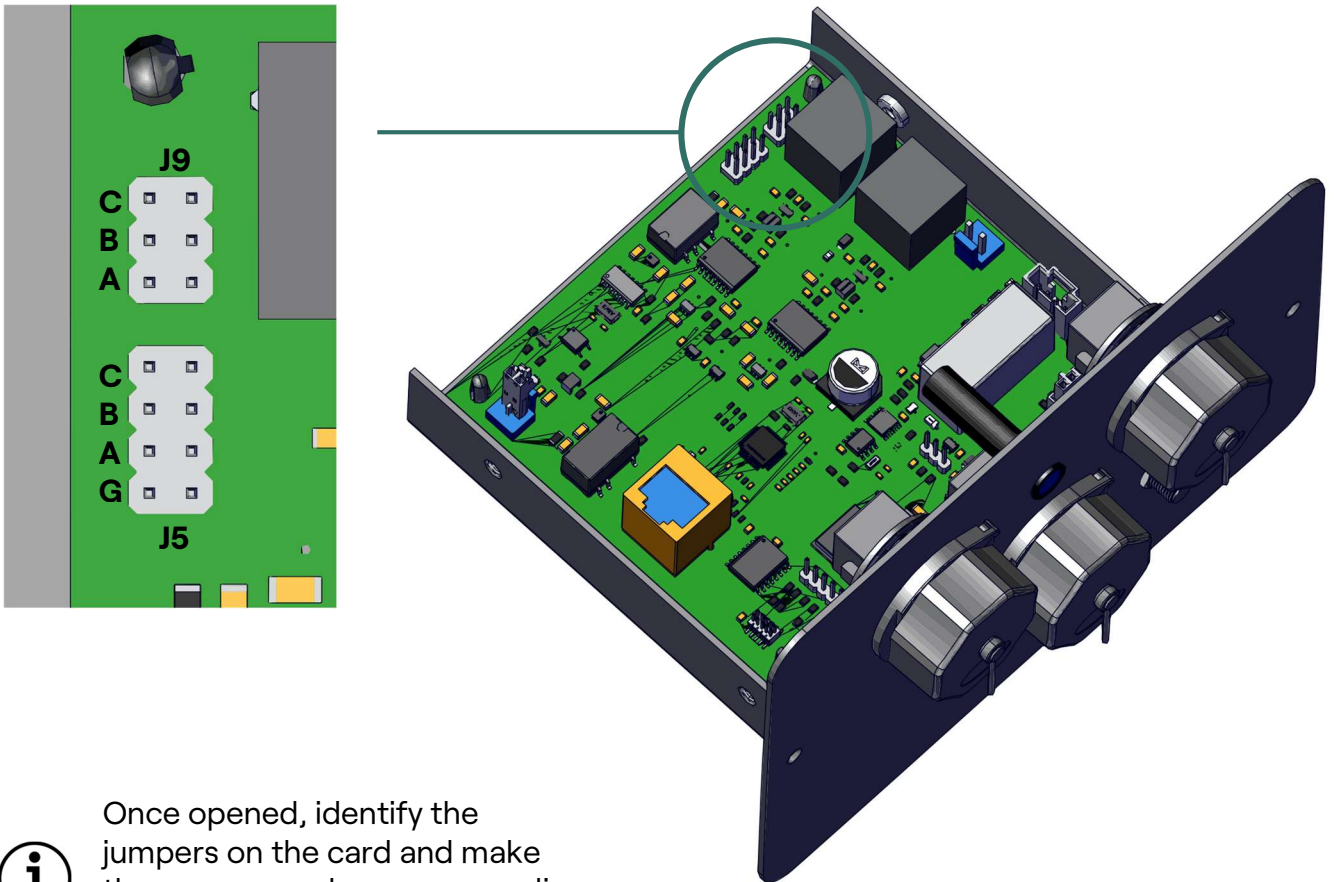

Once opened, identify the jumpers on the card and make the necessary changes according to the inverter to be used.

Inverter	J5	J9
Victron	CG	C
SMA	BG	B
Solis	BG	B
Solinteg	BG	B
Goodwe	BG	B

Inverter	J5	J9
Ingeteam*	BG	B
Sofar*	BG	B
Studer**	-	-
Selectronic	A	A

*Custom cable required (CAN_H PIN4, CAN_L PIN5)
 **Ask CEGASA

Finally, close the unit again doing the first step in this section in reverse.

Next, continue with the installation of the single tower in Step 9 (page 22) and two towers in Step 1 (page 45).



Energy you can trust

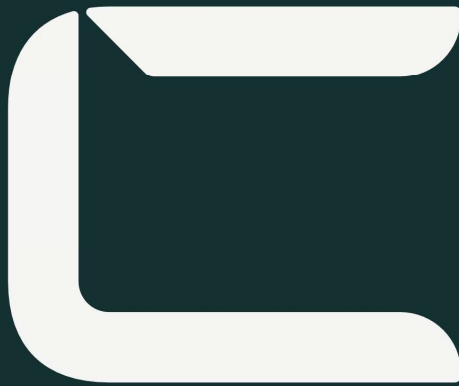

CEGASA

Spain. Production Centre
Cegasa Energía S.L.U.
Parque Tecnológico de Álava, Calle Marie Curie 1
01510 Miñano, Vitoria-Gasteiz (Álava, Spain)

www.cegasa.com
hello@cegasa.com

+34 945 31 37 38