

CEGASA

Energy you can trust



E/Xpand HV

User Manual

Original manual
September 2025

Control of revisions

DATE	DESCRIPTION
April 2025	Document created
Sept. 2025	Content update

Table of Contents

1	<u>Introduction</u>	<u>7</u>
1.1	<u>Purpose.....</u>	<u>7</u>
1.2	<u>Target.....</u>	<u>7</u>
1.3	<u>Page format.....</u>	<u>8</u>
1.4	<u>Symbols used.....</u>	<u>9</u>
1.5	<u>Acronyms.....</u>	<u>10</u>
1.6	<u>Language.....</u>	<u>10</u>
1.7	<u>Declaration of conformity.....</u>	<u>10</u>
1.8	<u>Limitation of warranties and liability.....</u>	<u>11</u>
1.9	<u>Confidentiality</u>	<u>11</u>
1.10	<u>Manufacturer information</u>	<u>11</u>
2	<u>Safety</u>	<u>12</u>
2.1	<u>Intended use</u>	<u>12</u>
2.2	<u>Rating plates</u>	<u>13</u>
2.3	<u>General information.....</u>	<u>14</u>
2.4	<u>Safety instructions.....</u>	<u>14</u>
2.4.1	<u>General.....</u>	<u>16</u>
2.4.2	<u>Mechanical.....</u>	<u>17</u>
2.4.3	<u>Fire prevention measures</u>	<u>17</u>
2.4.4	<u>Anti-electrolyte measures.....</u>	<u>17</u>
3	<u>Description of the system</u>	<u>18</u>
3.1	<u>Description.....</u>	<u>18</u>
3.2	<u>Line architecture</u>	<u>21</u>
3.3	<u>Main features</u>	<u>22</u>

3.4	Control architecture	23
3.4.1	BMS – Module	25
3.4.2	BMU – String.....	25
3.4.3	EXpand MASTER MCS – Battery System	25
3.5	Interface - BMU.....	26
3.5.1	Front face.....	26
3.5.2	Rear face.....	26
3.5.3	EXpand Master MCS	28
3.6	Distribution and protection cabinets (PDC).....	29
3.6.1	110217 PDC 600 A 3E.....	29
3.6.2	110218 PDC 1000 A 5E	29
3.6.3	110219 PDC 2000 A 10E.....	30
4	Processes and modes of operation.....	31
4.1	State machine description	31
4.1.1	State of operation	31
4.1.1.1	Single string system	31
4.1.1.2	Multi-string system	32
4.1.2	States of protection.....	33
4.1.3	Operating modes	34
4.2	Equalisation.....	34
5	System configuration and start-up.....	35
5.1	Web app connection	35
5.2	Powering the system	35
6	System operation.....	38
6.1	System start-up.....	38
6.2	System shutdown.....	39
6.3	Recommendations for use (charging and discharging)	41

7	<u>System scalability</u>	42
7.1	<u>Increase number of strings</u>	42
7.2	<u>Increase number of Modules per string</u>	43
8	<u>Troubleshooting</u>	44
9	<u>System disassembly</u>	47
10	<u>Disposal system</u>	49
11	<u>Transport and storage requirements</u>	50
11.1	<u>Shipment</u>	50
11.2	<u>Environmental requirements for use</u>	50
11.2.1	<u>Storage recommendations:</u>	51
11.2.2	<u>Deviations:</u>	51
12	<u>Maintenance plan</u>	52
12.1	<u>Maintenance plan</u>	52
12.1.1	<u>Training and Safety</u>	52
12.1.2	<u>Cleaning</u>	52
12.1.3	<u>Storage</u>	52
12.1.4	<u>Temperature</u>	52
12.1.5	<u>Regular Visual Inspection</u>	52
12.1.6	<u>Voltage control</u>	52
12.1.7	<u>Full charge</u>	53
12.1.8	<u>Deep discharges</u>	53
12.1.9	<u>Checking notices and alarms</u>	53
12.1.10	<u>Log and documentation</u>	53
12.1.11	<u>Updating firmware</u>	53
12.2	<u>Corrective maintenance plan</u>	53

13	<u>Technical data sheet (TDS)</u>	54
14	<u>Specific inverter annexes</u>	56
	<u>A1 Warranty document</u>	<u>56</u>
	<u>A2 CAN bus communications protocol</u>	<u>56</u>
	<u>A3 MOD bus communications protocol</u>	<u>56</u>
	<u>A4 System configuration with the EViewer web app</u>	<u>56</u>
	<u>A5 IP configuration of PC devices</u>	<u>56</u>

1 INTRODUCTION

1.1 PURPOSE

This complete manual provides the description, configuration, operation and maintenance of the energy storage system made up of the following products.

Table 1-1. Glossary.

Term	Definition
Module	HV EXpand Module.
BMU	HV EXpand BMU control unit.
Master	Master MCS unit.
PDC	Distribution and protection cabinets.
Inverter	Hybrid inverter.
Frame	Metal cabinet for housing Modules and BMUs
Rack	Group of modules assembled on a frame.
String	Group of modules connected in series, assembled on one or more racks and controlled by an HV EXpand BMU control unit.
Battery System	Energy storage battery system.
EViewer web app	Battery system monitoring platform.
CEGASA Cloud	Cloud platform.

1.2 TARGET

The instructions contained in this document can only be carried out by qualified people with the following skills:

- Knowledge of how Battery Systems work.
- Knowledge of how an inverter works and is operated.
- Knowledge of and compliance with applicable requirements, standards and connection requirements.
- Knowledge of and compliance with this document and associated system documentation, including all safety instructions.
- Training to address the risks associated with the installation and operation of electrical equipment and batteries.
- Training in installation and commissioning of electrical equipment.

If this is not observed, the manufacturer's warranty and/or liability will be null and void unless it can be proven that the damage is not related to failure to comply with this requirement.

1.3 PAGE FORMAT

Each page of this manual has the following information.

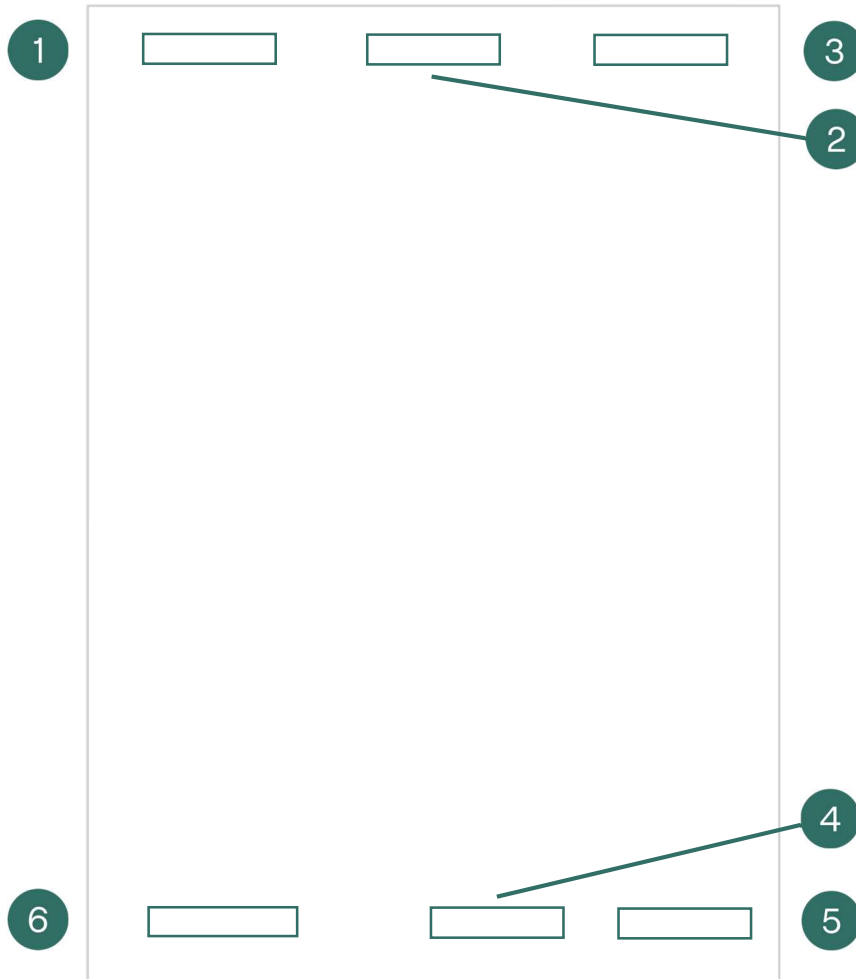

Figure 1-1. Page format.

Table 1-2. Page format.

Item	Description
1	Product name.
2	Manual name.
3	Revision of the manual.
4	Brand slogan.
5	Page number.
6	CEGASA logo.

1.4 SYMBOLS USED

The following information tables are used throughout this manual:

 DANGER!

Indicates a hazardous situation which, if not avoided, will result in death or serious injury.

 WARNING!

Indicates a hazardous situation which, if not avoided, may result in death or serious injury.

 CAUTION!

Indicates a hazardous situation which, if not avoided, may result in moderate or minor injuries.

 NOTICE

Information related to conditions, practices or procedures that may pose a risk to machine integrity.

 INFORMATION

Information to bear in mind.

 ENVIRONMENTAL

Information related to conditions, practices or procedures that may pose a risk to the environment.

The following short notes can also be used to replace full-size notes:

 **Danger: Information related to conditions, practices or procedures that pose a risk to individual safety.**

 **Warning: Information related to conditions, practices or procedures that pose a risk to machine integrity.**

 **Caution: Information related to conditions, practices or procedures that pose a risk to machine integrity.**

 **Notice: Information related to conditions, practices or procedures that may pose a risk to machine integrity.**



Information: Information to bear in mind.



Environmental: Information related to conditions, practices or procedures that may pose a risk to the environment.

1.5 ACRONYMS

Table 1-3. Acronyms.

	Meaning
LFP	LiFePo4
BMS	Battery management system
SCS	String control system
SoC	State of charge
SoH	State of health
SoP	State of power
EMS	Energy Management System
CB	Circuit breaker

1.6 LANGUAGE

The original language of the equipment manufacturer is Spanish. Any other language in which the user manual is written is considered a translation from Spanish to the language used by the end user.

If any section or part of the translated manual is not clearly expressed or is not correctly understood, users have the manual in the original language of the manufacturer supplied together with the translated manual.

1.7 DECLARATION OF CONFORMITY

The Battery System described in this document complies with applicable European directives.

1.8 LIMITATION OF WARRANTIES AND LIABILITY

The limitation of warranties and liability will be described in the contractual agreements between CEGASA ENERGIA SLU and the purchaser (see Annex A1 Warranty *document*”).

The information included in this manual has been written to provide users with the highest degree of detail and clarity on all the content. However, CEGASA ENERGIA SLU reserves the right to modify the content of this manual through future revisions at any time and without prior notice.

This document does not replace nor does it aim to replace any local, state, provincial, federal or national laws, regulations and codes applicable to the installation, electrical safety and use of the Battery System. CEGASA ENERGIA SLU assumes no liability for compliance or non-compliance with such laws or codes in relation to the installation of the Battery System.

1.9 CONFIDENTIALITY

All the information provided by CEGASA ENERGIA SLU by virtue of this manual and any data or aspects that may become known as a result thereof will be absolutely confidential, and may not be provided to third parties or used for any purpose other than that intended, without the prior and express written authorisation of CEGASA ENERGIA SLU, (hereinafter CEGASA).

1.10 MANUFACTURER INFORMATION

Contact CEGASA with any questions or queries at the following address:

Parque Tecnológico de Álava
Marie Curie 1, CP 01510 Miñano, Álava (Spain)
+34 945 228 469
info@cegasa.com
cegasa.com

2 SAFETY



DANGER!

The person responsible for the use of the system must ensure that anyone who operates the Battery System reads, understands and follows everything indicated in this user manual.

The Battery System has been designed and tested in accordance with international safety standards. Nonetheless, to avoid personal injury and property damage and ensure long-term operation of the system, please read this section carefully and follow all recommended safety measures.

2.1 INTENDED USE

The intended use of the Battery System is described below.

- It must only be used as stationary equipment.
- It can operate in on-grid and off-grid mode with exclusively compatible inverters. Consult with CEGASA for the list of compatible inverters.
- It can be connected to the internet via a network cable for monitoring, maintenance and firmware update tasks.
- It is suitable for indoor use, never outdoors.
- Alterations to any of the components that make up the Battery System, for instance, changes or modifications, are not permitted without prior written authorisation from CEGASA. Unauthorised modifications will void the warranty and rights over it. CEGASA will not be responsible for any damage caused by such changes to the equipment.



DANGER!

The Battery System cannot be used for any other purpose than that described in this manual.

2.2 RATING PLATES



Figure 2-1. HV EXpand module - Rating plate 1.



Figure 2-2. HV EXpand BMU control unit - Rating plate 1.

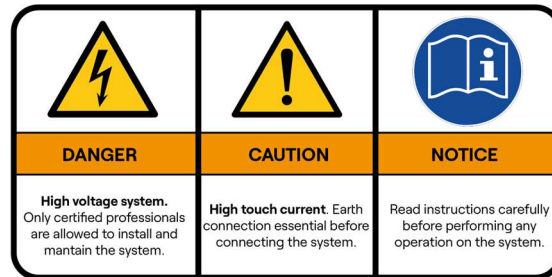

Figure 2-3. HV EXpand BMU control unit - Rating plate 2.

2.3 GENERAL INFORMATION

The entire Battery System has a high energy capacity. To minimise the risk of electric shock, short-circuit, explosion and/or fire, follow the relevant procedures and local guidelines, as well as the instructions set out in this manual.

To ensure that the Battery System is safe, all direct connections and terminals must be covered. Systems with visible electrical connections must also be isolated from public access.

Please read, understand and carefully apply the requirements indicated in this section.

2.4 SAFETY INSTRUCTIONS

NOTICE

Failure to follow safety instructions could result in serious injury, death or property damage.

DANGER!

The Modules must always be used with a CEGASA BMU control and protection system. Never connect the Modules without this control unit.

To avoid high energisation currents, pre-charge the bus. A direct connection could damage the system. This pre-charge is managed from the BMU.

DANGER!

Before connecting the Battery System to the inverter, check that the voltage of the string formed by Modules connected in series is within the working range of the inverter.

DANGER!

Never open and eliminate, bypass or modify the cutting and protection systems included in the BMU.

DANGER!

Use safety tools (EN 60900) and protective equipment during installation and service to avoid short-circuits and electric shock.

 DANGER!

Do not expose the Battery System to room temperatures higher than 50°C. The equipment must not be operational above these temperatures. In fact, even when the equipment is not operational, the exposure of the cells to high temperatures can cause fire and/or explosion.

 DANGER!

Never drop or knock the Modules or the BMU.

 DANGER!

If using inverters, only use those authorised by CEGASA. Misuse of the Battery System during charging or discharging can cause premature ageing of the equipment or even fire and/or explosion. The communications of both units are complex and must be run by authorised specialised personnel.

 DANGER!

Do not open the covers of the Modules. Do not place or drop conductive objects inside the Module or between its terminals.

 DANGER!

Do not short-circuit the terminals (positive and negative) of the Modules or the BMU. The short-circuit current can be several thousand amperes, generating a dangerous electrical arc.

 DANGER!

Do not bring into contact or fully or partially submerge the Module in water or any other liquid.

 DANGER!

In case of fire, turn off the circuit breaker (CB) located on the front of the BMU control unit and use a CO2 extinguisher or extinguishing agent recommended by local regulations to extinguish the fire. Do not try to put out the fire with water. The Modules contain flammable materials. Always notify firefighters about the installed Battery System.

 DANGER!

Ensure BMU control units are always properly grounded.

2.4.1 General

- The area around the Battery System must be kept clear and free of combustible materials, petrol and/or other flammable vapours and liquids.
- Any air inlet or outlet in the room must be clear and free of obstacles.
- There must be no signs of deterioration in any component of the Battery System. Contact CEGASA with any questions.
- Since it is a Battery System, whenever the contactors of the BMU are closed, there is high voltage between the terminals (+/-).
- Do not use the Modules if any of their parts have been totally or partially submerged in water or any other liquid. A water-damaged lithium cell is potentially dangerous. Attempts to use the Module could cause a fire or an explosion. In this case, contact CEGASA for an equipment inspection.
- Do not access the interior of the BMU, or the Modules, or manipulate any internal components.
- Do not use or manipulate the Battery System components if your feet or hands are wet.
- In the event of a fault or incident, cut off the power to the inverter as an initial measure.
- Ensure that there is no short-circuit between positive and negative terminals at any point.
- Follow the specifications proposed by CEGASA for the power and communications cables of the installation.
- Do not use, manipulate, install or store any of the components of the Battery System in locations with high humidity levels or subject to adverse weather conditions.
- Furthermore, a Battery System should never be installed in locations at an altitude of more than 2000 metres above sea level.

2.4.2 Mechanical

- The floor must be capable of holding the weight of the entire Battery System made up of one or multiple towers. The floor must be in optimal condition.
- Due to the weight of the Modules (>120 kg), they must be installed by several people.
- Stack the modules in the corresponding frame according to the installation, following the instructions (see EXpand Installation Manual).
- Brace/fix the frame to the wall at a height according to the instructions (see EXpand Installation Manual).

2.4.3 Fire prevention measures

- Ensure that a CO₂ extinguisher or extinguishing agent recommended by local regulations is nearby.
- Do not use water to extinguish the fire.
- Full protective clothing and self-contained breathing apparatus are required for firefighters to extinguish the fire.

2.4.4 Anti-electrolyte measures

If the Module loses electrolyte due to a Battery System malfunction, avoid contact with the leaking liquid or gas.

Electrolyte is corrosive and contact can cause skin irritation and chemical burns. In case of exposure to this substance, proceed as follows:

- Inhalation: Evacuate the contaminated area.
- Contact with eyes: Rinse eyes with cold water for 15 minutes.
- Contact with skin: Thoroughly wash the affected area with cold water and soap.
- Ingestion: Induce vomiting.

In any of the above cases, seek immediate medical assistance.

3 DESCRIPTION OF THE SYSTEM

3.1 DESCRIPTION

The HV EXpand line is a European-manufactured Battery System for the stationary environment with LFP technology, providing optimum quality, service, safety and cyclability.

The line consists of the following parts:

Parts	Measurements (cm)	Weight (kg)
HV EXpand Module	78x44x22	120
HV EXpand BMU control unit	60x44x22	34
EXpand Master MCS	21x14.5x8.5	1.2
9-module frame	55x80x237.5	94
8-module frame	55x80x215	75
6-module frame	55x80x164	58
9-module closure panel	2x70.5x226	17
8-module closure panel	2x70.5x203.5	15
6-module closure panel	2x70.5x158.5	12
Rack kit (for several racks)	29x25x15	2

1. HV EXpand Module (51.2 V - 280 Ah; 14.3 kWh)

Designation according to standard (IEC 62620:2014); IFpP74/175/208[1P16S]M/0+50/90

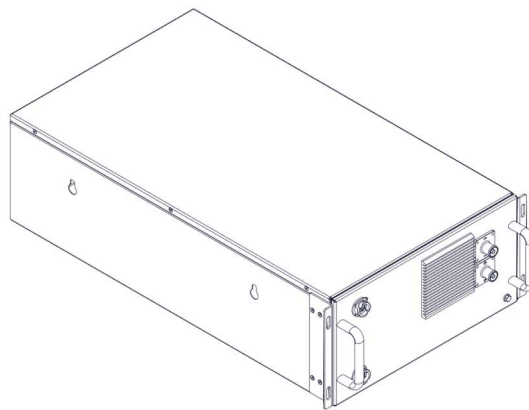

Figure 3-1. HV EXpand Module.

2. HV EXpand BMU control unit

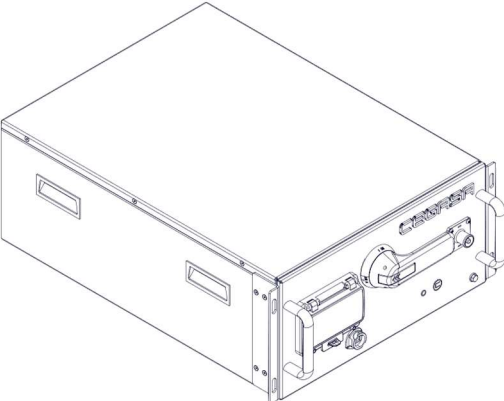

Figure 3-2. HV EXpand BMU control unit.

3. EXpand Master MCS

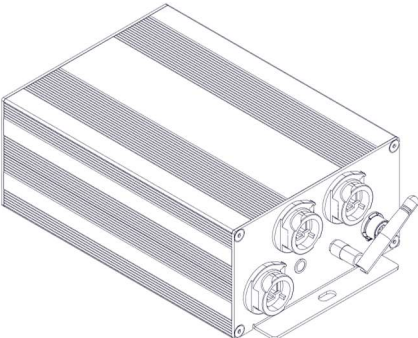

Figure 3-3. EXpand Master MCS.

4. Frame

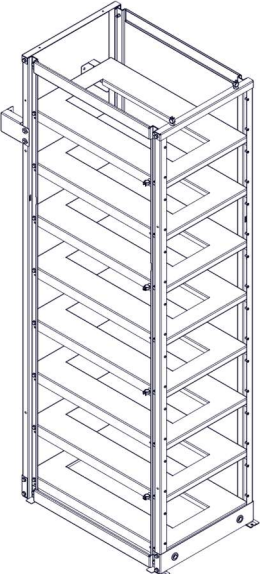

Figure 3-4. Frame.

5. Closure panel



Figure 3-5. Closure panel.

3.2 LINE ARCHITECTURE

The HV EXpand line is based on three connection levels:

1. **Rack.**

Modules can be stacked in one of the frames offered by CEGASA (6–8–9 levels) depending on the selected configuration.

2. **String.**

This is a set of modules (6 to 18 modules) connected in series (assembled on one or more frames forming racks), controlled by a BMU and with connectivity provided by a master unit that the installer must connect to the BMU, as explained in the HV EXpand installation manual.

3. **System.**

Up to a maximum of 10 strings can be connected in parallel through an electrical cabinet (CEGASA has its own PDC references, please enquire). For the systems, a single Master unit is necessary for connectivity functions. It must be connected inside one of the system’s BMU control units by the installer, as described in the HV EXpand installation manual.

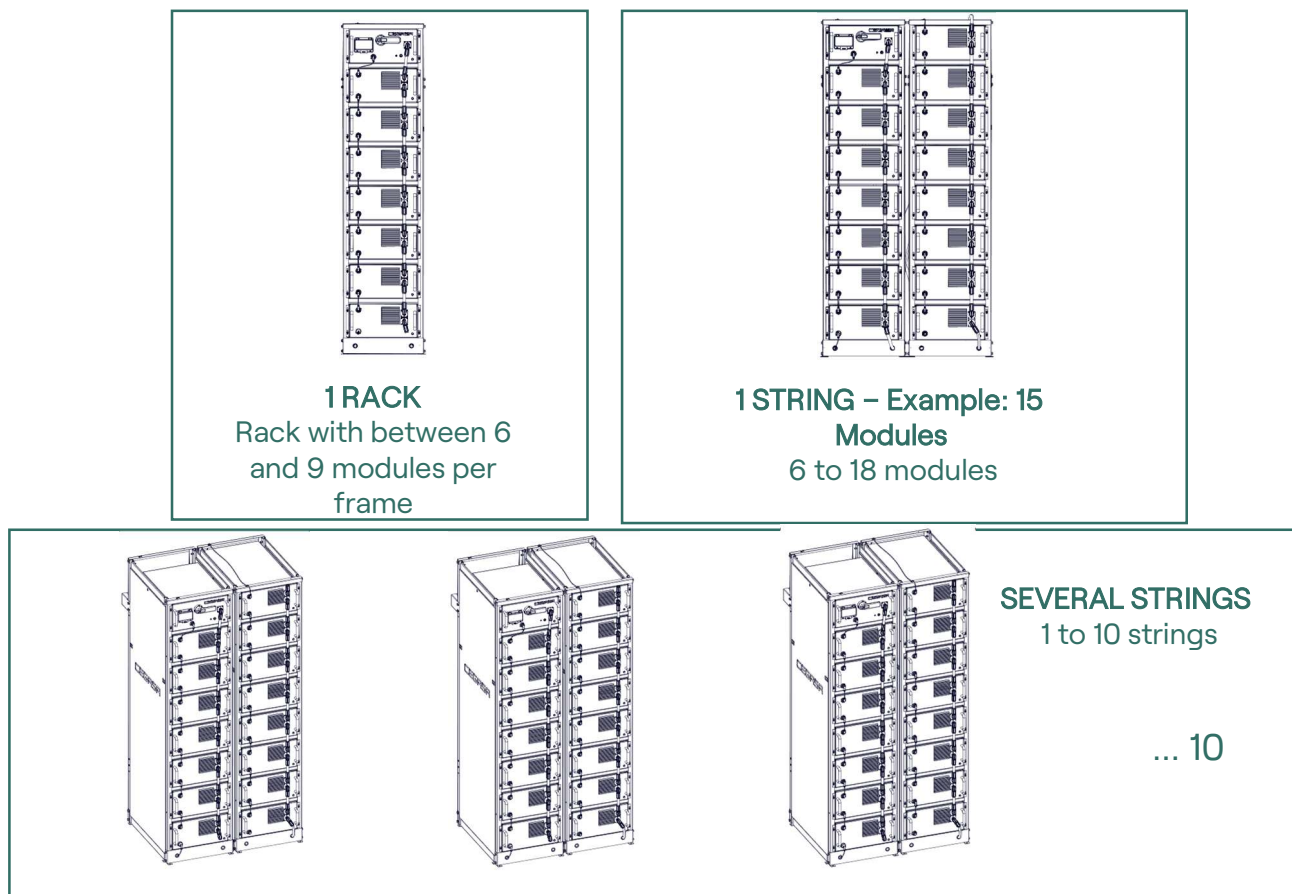

Figure 3–6. Architecture of the line.

3.3 MAIN FEATURES

- Modular design. A string can be made up of between 6 and 18 Modules connected in series and controlled by an EXpand BMU control unit.
- Power and communications connections are made with quick and safe connectors (without the need for tools).
- Possibility of parallelising up to 10 strings in a Battery System.
- Compatible with the most relevant high voltage inverters (single-phase and three-phase) on the market. Communications (CAN bus and MODBUS).
- Automatic recognition of Modules in the installation by the EXpand BMU.
- Start and stop with the ON/OFF button on the front of the BMU, which has a controlled DC bus pre-charging system.
- Protections for short-circuits, overcurrent, voltages, temperatures, etc.
- Simple system, designed to facilitate the disassembly and repair of electronic components.
- Wi-Fi module to facilitate local communications with its own application for configuration, management, data analysis, etc.
- Remote diagnosis with the EViewer web app developed by CEGASA.

3.4 CONTROL ARCHITECTURE

CEGASA's HV EXpand line offers a modular and scalable system that adapts to the installation's voltage and energy needs. For this, the system has a three-level control architecture: Module (BMS), String (BMU) and System (MASTER).

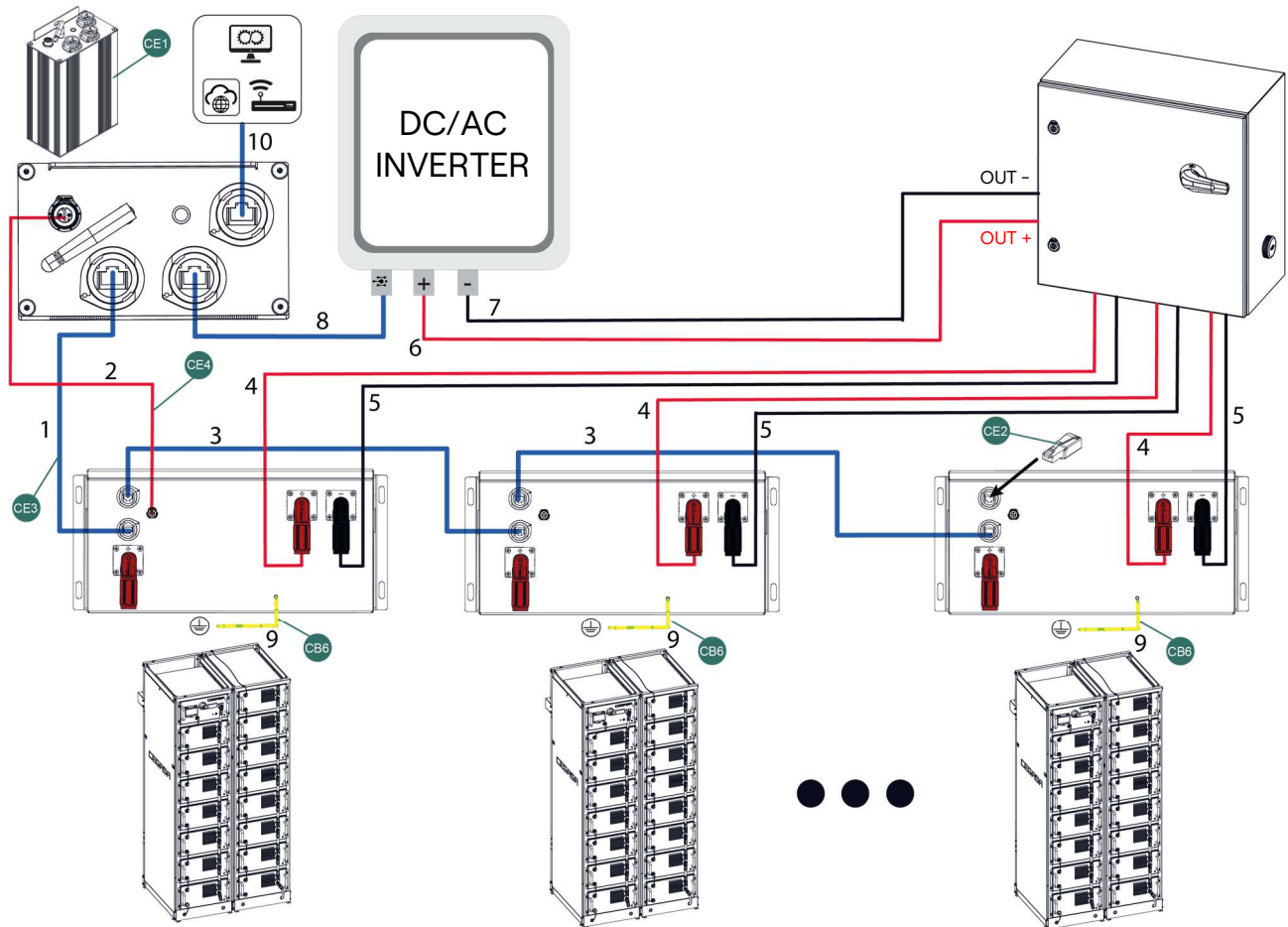

Figure 3-7. Control architecture.

Table 3-1. Connection cables.

Item	Type of cable	Features
1	EXpand Master-BMU COMMS cable	Cat5e (min.) UTP network cable, standard parallel.
2	EXpand Master external power cable	Cable with 0.5 mm ² section.
3	InterBMU COMMS cable	Cat5e (min.) UTP network cable, standard parallel (not included).
4	OUT (+) power cable	1000 Vdc cable with 70 mm ² section (not included).
5	OUT (-) power cable	1000 Vdc cable with 70 mm ² section (not included).
6	OUT (+) power cable Cabinet-Inverter	1000 Vdc cable with 70 mm ² section (not included).
7	OUT (-) power cable Cabinet-Inverter	1000 Vdc cable with 70 mm ² section (not included).
8	COMMS (Can bus-TCP/IP) cable to the Inverter	Cat5e (min.) UTP network cable, standard parallel (not included).
9	Earthing cable	Earthing cable with 10 mm ² section.
10	COMMS (MODBUS) cable to PC	Cat5e (min.) UTP network cable, standard parallel (not included).

3.4.1 BMS – Module

At this level, the unit voltages of each cell and their temperatures at various points are recorded and sent via an ISO SPI communications bus to the next higher control level (BMU).

3.4.2 BMU – String

Each group of Modules connected in series (called a string) is connected both in power and communications to the EXpand BMU.

The function of the BMU control unit is to provide each group of Modules (connected in series) with the necessary short-circuit and overload protections (voltage, current, temperature), perform the safe connection/disconnection of said group, perform thermal management, estimate Module group variables, manage alarms and, finally, manage the equalisation of the various Modules. For this purpose, it also has protection elements and electronics that perform this management based on the value of the variables obtained from the BMS.

Each BMU has the following protection systems on each pole (positive and negative): bidirectional contactors with status control and 450 A fast-acting fuses specifically for batteries. It also has a manual isolation switch on the front for both poles and a circuit breaker to automatically disconnect a string in the event of a deep overdischarge.

3.4.3 EXpand MASTER MCS – Battery System

The third level in the control architecture is the Master. Electronics that enable system connectivity and allow communication between the inverter, CEGASA Cloud, EViewer platform and EMS.

The Master unit has two communication protocols to communicate with different inverters and EMS: CAN bus and MODBUS TCP/IP.

Connection with the CEGASA Cloud and CEGASA web app can be carried out both by using the ETHERNET port (cable) and wirelessly via Wi-Fi connectivity.

The various groups of Modules connected in series (strings) can in turn be connected in parallel in order to increase the total capacity of the system through a protection, distribution and connection cabinet (PDC). In addition to providing the corresponding external connectivity, the Master unit in these string systems connected in parallel manages the different strings using the CAN bus which connects the various BMUs comprising the system.

The Master unit configures the cards of each BMU, sends the connection/disconnection commands and aggregates the variables of each string.

3.5 INTERFACE - BMU

As detailed, each string of Modules must be connected to its control with a BMU. The interfaces of the EXpand BMU are detailed below.

3.5.1 Front face



Figure 3-8. BMU front.

3.5.2 Rear face

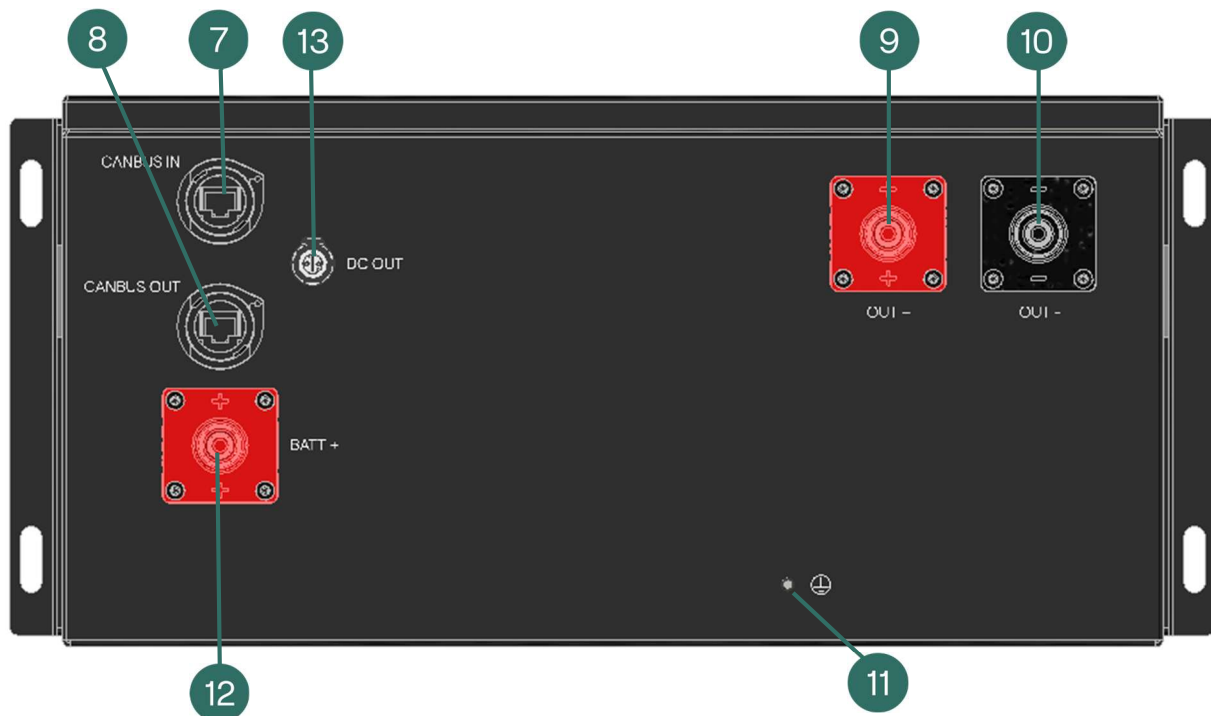

Figure 3-9. BMU rear.

Table 3-2. Front, rear and side EXpand BMU interfaces.

Item	Name	Description
1	Start/stop button	Button for closing the string contactors. Includes two-colour (red/green) LED to indicate the status of the string.
2	Mode LED	LED indicating the operating mode of the string.
3	BATT-	Negative pole power connection of the string.
4	Manual isolation switch	Isolation switch actuator lever. Use without charge (under no-load condition).
5	BATT COM	BMU-Module communications connector
6	Circuit breaker (CB)	Thermal magnetic circuit breaker. To connect/disconnect the string. It adds automatic deep overdischarge protection.
7	CAN BMU (In)	CAN bus input connector.
8	CAN BMU (Out)	CAN bus output connector.
9	OUT+	Positive pole power connection from the string to the inverter.
10	OUT-	Negative pole power connection from the string to the inverter.
11	Earth	Earth connection.
12	BATT+	Positive pole power connection of the string.
13	DC OUT	EXpand Master external power cable

3.5.3 EXpand Master MCS



Figure 3-10. BMU rear with Master MCS.

Table 3-3. Master MCS unit interface.

Item	Name	Description
14	CAN BUS BMU	CAN bus connector to connect the BMU to the EXpand Master MCS
15	CAN BUS INVERTER	CAN bus connector to connect to the inverter.
16	DC IN	EXpand Master external power cable
17	ANTENNA	Wi-Fi connection antenna
18	Mode LED	LED indicating the operating mode of the Master MCS
19	ETHERNET	Ethernet and MODBUS TCP/IP connector.

3.6 DISTRIBUTION AND PROTECTION CABINETS (PDC)

CEGASA has three models of electrical cabinets to be able to connect and protect up to 10 200 A inputs each. The design of these cabinets and all their components comply with the applicable safety regulations for energy storage systems.

All cabinets have fast-acting fuses (*gBat*) that are specifically for Battery Systems, with the ability to automatically cut off the current flow of both poles (positive and negative) of each of the inputs to protect against overcurrent and short-circuit.

The fuses are placed in quick connection and disconnection fuse holders (always under no-load condition, ensuring that there is no current flowing through any of the inputs). Contact CEGASA if you require any spare parts for these fuses.

A manual isolation device is also included in the cabinet door to isolate (under no-load condition) the entire Battery System so that disconnections can be carried out for maintenance tasks in the final installation.

 CAUTION!

Before disconnecting the system, make sure the Battery System is turned off, see Section 6.2 “*System shutdown*”; and therefore, the value of the current in the batteries is ZERO amperes.

These are IP55 metal cabinets to be placed and fixed on the floor, with power cable entry at the bottom (socket always included).

The references of the PDC cabinets for the HV EXpand line are as follows:

3.6.1 110217 PDC 600 A 3E

- For systems with up to three strings connected in parallel (600 A_Max).
- Measurements 900x800x300 mm.
- Weight: 70 kg

3.6.2 110218 PDC 1000 A 5E

- For systems with up to five strings connected in parallel (1000 A_Max).
- Measurements 900x1000x300 mm.
- Weight: 130 kg

3.6.3 110219 PDC 2000 A 10E

- For systems with up to eight strings connected in parallel (2000 A_Max).
- Measurements 1653x1006x508 mm
- Weight: 280 kg

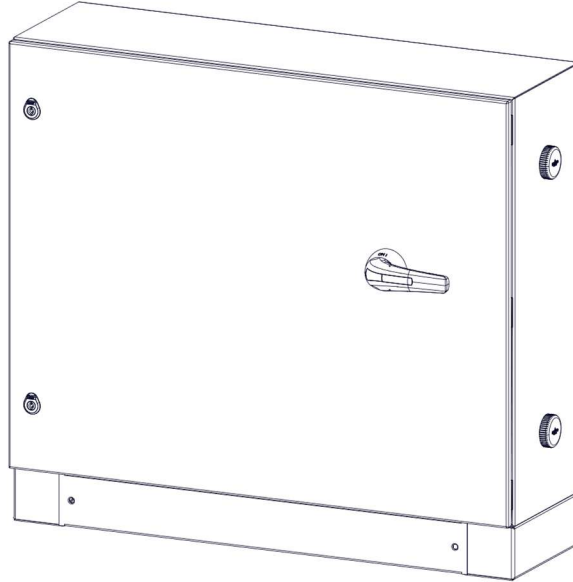

Figure 3-11.PDC Cabinet.



INFORMATION

Please contact CEGASA if you require more technical information.

4 PROCESSES AND MODES OF OPERATION

4.1 STATE MACHINE DESCRIPTION

The Battery System has different ways to show the state it is in at all times. Users will be able to connect via the EViewer web app where they will find detailed information about it. The BMU also integrates light indicators with different codes detailed below.

4.1.1 State of operation

The Battery System passes through different states depending on the system's work mode. The light indicator on the start/stop button modifies its emission code depending on the state of the string.

Each of the possible states is described below, both for single string systems and for systems with multiple strings (check the corresponding table for the system).

4.1.1.1 Single string system

INFORMATION







The LED flashes slowly.



The LED flashes quickly.

Table 4-1. Single string states.





LED button	State	Description
	Start-up	When the BMU is powered up by enabling the circuit breaker (CB) (up position), the BMU goes into the Start-up state while initialising (yellow LED). Once started and enabled by the Master, the system shifts to the next state, Ready .
	Ready	From the Ready state, users can close the BMU contactors by pressing the start/stop button for 5 seconds and shifting to the Connecting state.
	Connecting	Contactors closure is executed by performing a pre-charge to protect the BMU contactor and the inverter, an action that is carried out automatically in this state. Once the pre-charging process is completed, the system will automatically shift to the Run state. This process can take several seconds depending on the inverter.
	Run	Once in the Run state, the BMU contactors will be closed and therefore current will be able to flow through the string. (*)

LED button	State	Description
	Shutdown	The Battery System should preferably be switched off from the Ready state. To shift to the Ready state, press the start/stop button for 5 seconds. From here we can definitively turn off the BMU by disabling the circuit breaker (CB) (down position).

(*) If the BMU cannot reach this state, see chapter 8 "Troubleshooting".

4.1.1.2 Multi-string system

Table 4-2. Multi-string states.



LED button	State	Description
	Start-up	When all the BMUs are powered up by enabling the corresponding circuit breaker (CB) (up position), each BMU will go into the Start-up state while initialising (yellow LED). Once started and enabled by the Master, the system will shift to the next state, Ready .
	Ready	From the Ready state, users can close the contactors of all BMUs by pressing the start/stop button of just one of them for 5 seconds and shifting the System to the Connecting state.
	Connecting	All the BMUs perform a pre-charging process to protect their contactors and the inverter, an action that is carried out automatically in this state. Once the pre-charging process is completed, the system will automatically shift to the Run state. This process can take several seconds depending on the inverter.
	Run	Once in the Run state, the contactors of all the BMUs will be closed and therefore current can flow through the strings. (*)
	Shutdown	The Battery System should preferably be switched off from the Ready state. To shift to this Ready state, press the start/stop button of one of the BMUs for 5 seconds. From here we can definitively turn off each of the BMUs by disabling the corresponding circuit breaker (CB) (down position).

(*) If the BMU cannot reach this state, see chapter 8 "Troubleshooting".

4.1.2 States of protection

The system also has three protection levels: **Caution**, **Warning** and **Alarm**.

Table 4-3. States of protection.

LED button	State	Description
	Caution	The first protection level is Caution . In this state, the Master limits the corresponding current setpoint to 0 (Charge and/or Discharge) depending on the event. (*)
	Warning	If the Battery System exceeds any Warning level, the BMU of the corresponding string will shift to the Ready state of operation and the contactor will open to protect the string. (**)
	Alarm	Finally, at the Alarm level, the BMU of the corresponding string shifts to the alarm state and the affected BMU will need to be reset manually. Check the cause of entry into this alarm state with the help of the web app.



(*) If the event conditions are restored, the BMU will perform up to 6 automatic resets for 1 hour in case of **Caution**. If the problem persists, the BMU will shift to the alarm state.

(**) If the event conditions are restored, the BMU will perform up to three automatic resets for 1 hour in case of **Warning**. If the problem persists, the BMU will shift to the alarm state.

4.1.3 Operating modes

In addition to the different states, the string has different operating modes that are indicated with the mode LED (blue LED).

Table 4-4. Operating modes.

Mode LED	Operating modes	Description
	Start-up	During start-up, before actually entering the Start-up state, the blue LED indicates that the system is starting up.
	Disabled	If the BMU has not been enabled by the Master, the blue LED will remain on
	Enabled	If the BMU is in Ready state, the mode LED will be turned off while it is enabled

4.2 EQUALISATION

Each of the Modules that make up the Battery System is equipped with a passive equalisation system with the objective of balancing the state of capacity of the cells of each Module.

The equalisation process is controlled by the Master of the Battery System, which is responsible for starting the process when there is an imbalance between Module cells and also for stopping this process when the imbalance has been mitigated.

5 SYSTEM CONFIGURATION AND START-UP

NOTICE

The installation work has been completed in accordance with the Installation Manual.

5.1 WEB APP CONNECTION

The Battery System has a web app called EViewer that helps the user and/or installer to configure, monitor and update the equipment. This app runs on any web browser and therefore can be used with any device that has a browser installed, such as a smartphone, laptop or tablet.

To run this web app, the first step is to turn on the Battery System to power the Master unit and achieve connectivity.

5.2 POWERING THE SYSTEM

The steps to follow to power the master unit and achieve connectivity are described below.

INFORMATION

Check the configuration of the Master unit, see Point 6 of the Installation Manual. "*Configuration of the MASTER unit*".

INFORMATION

Check the Battery System's power and communications connections.

INFORMATION

The assignment of the parallel IDs is done in order of response and may not coincide with the order in which the BMUs are installed. If you want the assignment to correlate with the installation, they must be switched on in the desired order with a waiting time of at least 5 seconds between them.

NOTICE

Do not connect the Battery System to the inverter until configuration is completed.

1. Power all the Battery System's BMUs. To do so, enable (up position) the circuit breaker (CB) of all BMUs.

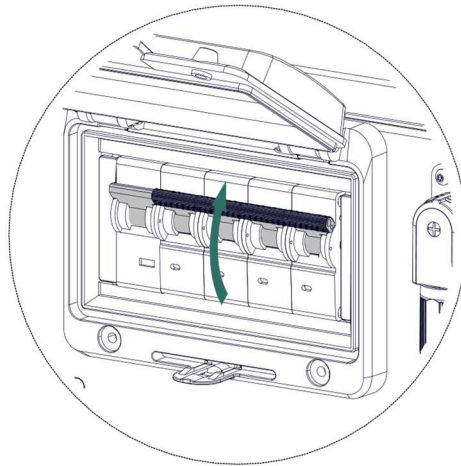

Figure 5-1. Connect the CBs.

2. Enable the isolation device lever (turn to the left) of all BMUs (**ON position**).

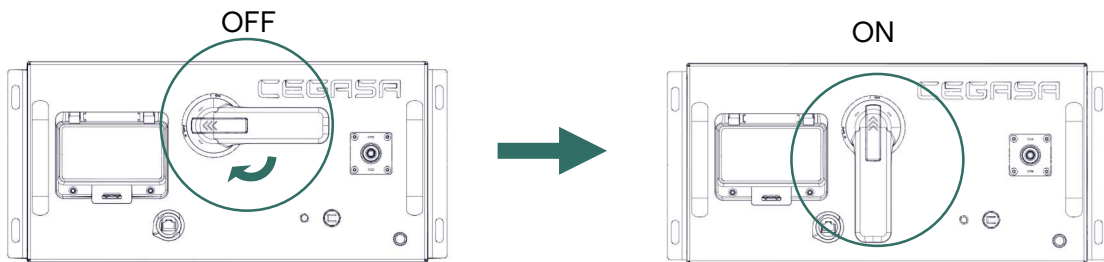

Figure 5-2. Lever in ON position.

Check the LED (flashing green) of all the front buttons comes on.

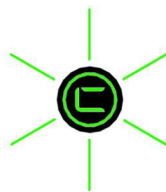

Figure 5-3. Front buttons.

NOTICE

DO NOT PRESS the front buttons until configuration is complete.

3. Using the EViewer platform, connect the system via Wi-Fi or an Ethernet network:

a. **Ethernet cable connection (Recommended for laptops)**

- Connect an Ethernet cable between the laptop and the ETHERNET port on the Master unit. A Cat5e or higher parallel network cable is recommended.

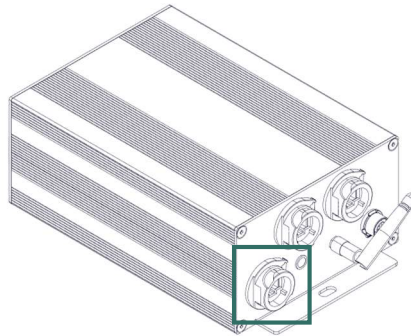

Figure 5-4. Rear of Master unit.

- Configure the IP of the device connected to the Master MCS to adjust the IP range to the 192.168.55.XXX network (when in doubt, see Annex 5 "IP configuration of PC devices").
 - Open a web browser on the device and enter the following IP address: <http://192.168.55.180>.
- b. **Wi-Fi connection (Recommended for mobile devices)**
- Open the Wi-Fi network settings on the device.
 - Find the Wi-Fi network called "MCS_XXXXXX" (Where XXXXX corresponds to the serial number of the MCS) and connect using the following password: **Cegasa24**
 - Open a web browser on the device and enter the following IP address: <http://10.0.0.1>

i INFORMATION

If you are using a mobile device, disconnecting the mobile data connection is recommended.

Wi-Fi connection only available for mobile devices that use the Android operating system.

i INFORMATION

From this point, continue with the system configuration as explained in Annex A4 *System configuration with the EViewer*.

In case of connection problems, see Chapter 8 "Troubleshooting".

6 SYSTEM OPERATION

Once the battery system is powered, configured and connected to an inverter, users can charge or discharge the system through the inverter.

INFORMATION

Fully charging the system at the start to calibrate the system's SoC value is recommended.

6.1 SYSTEM START-UP

Once the system has been configured on the EViewer platform (as mentioned in the point above), the system will restart to begin to operate with the final configuration. After this restart process (which may take several seconds depending on the number of BMUs and modules in the system), the blue BMU mode LED will turn off and the BMU buttons will be lit in the **Ready** state (slowly flashing green) waiting to be initiated.

To start the Battery System, press the front start/stop button of the BMU for 5 seconds (or one of the BMUs if there are several). This starts the contactor closing process for each of the BMUs, always activating the pre-charging process beforehand. In this process the system passes through the **Connecting** state (green LED flashing quickly).

Once the pre-charging process is completed, the system enters **Run** state and the strings can receive or deliver current from the inverter if it demands it.

In this **Run** state the LED of the button for all the BMUs will remain in a **fixed green state**.

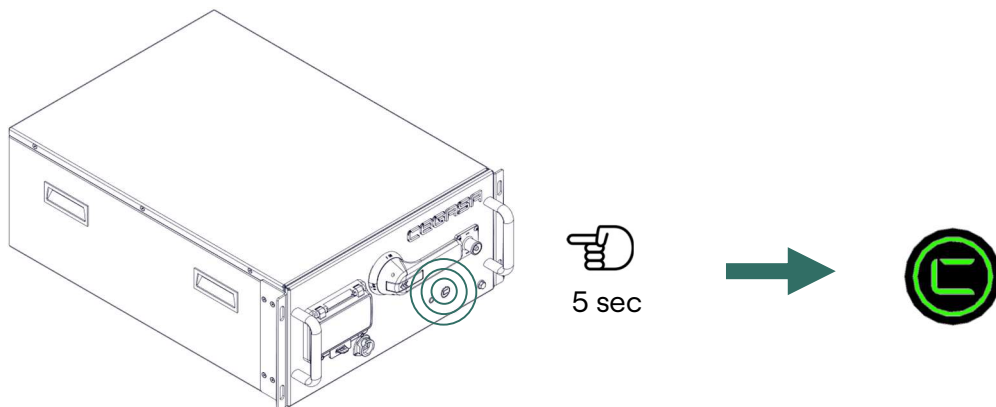

Figure 6-1. System start-up.

Customers can use the EViewer platform to check if the Battery System is connected and each of the strings is being charged/discharged correctly. If any of the BMUs does not reach this state, see chapter 8, "*Troubleshooting*".

6.2 SYSTEM SHUTDOWN

To shut down the Battery System, users must first ensure that no charging or discharging current is circulating through the strings. This can be checked using the EViewer platform, viewing the current passing through the system and its state.

Once the circulating current has stopped, press the start/stop button (5 seconds) on any of the BMUs until all the contactors open. This will cause each of the BMUs comprising the system to go from the *Run* state to *Ready* state.

In this Run state the LED on the button of all the BMUs will remain in a flashing green state.

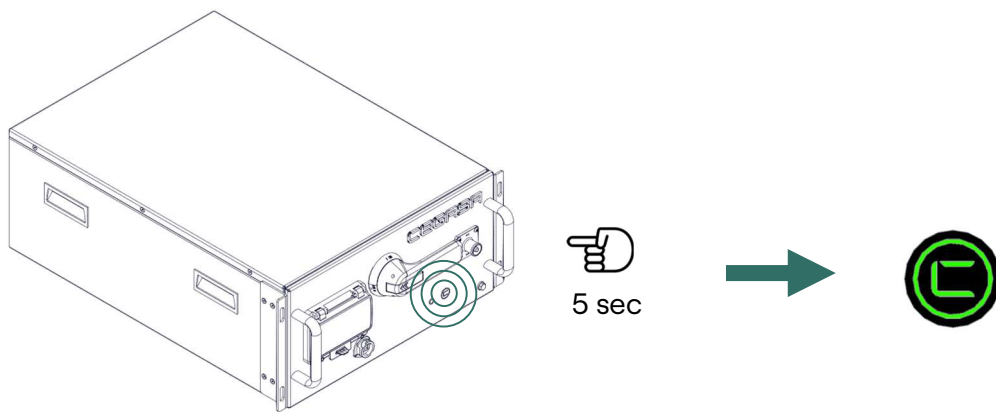

Figure 6-2. System shutdown.

Once in this state, the Battery System can be turned off by disabling the circuit breaker (CB) (down position) of each of the BMUs.

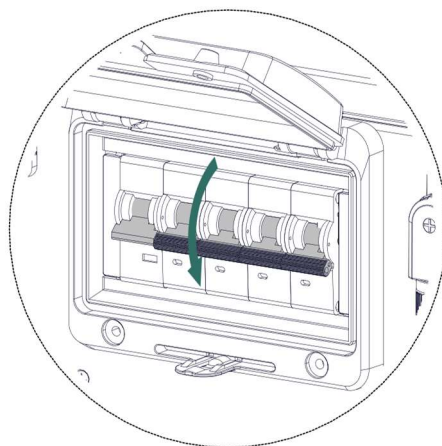

Figure 6-3. Disconnect the CBs.

And place the isolation device lever in the **OFF** position .

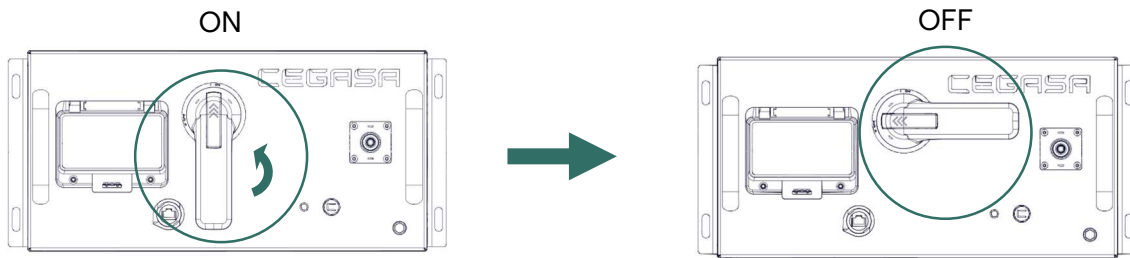

Figure 6-4. Lever in OFF position.

i NOTICE

Remember to disable the circuit breakers (CB) (down position) of all the BMUs if the Battery System is not going to receive any charge for a period of time longer than two weeks, since the internal consumption of the electronics could consume the energy of the Battery System.

6.3 RECOMMENDATIONS FOR USE (CHARGING AND DISCHARGING)

The Master adjusts the voltage and current setpoints depending on the working point and the state of each of the strings.

Table 6-1. Recommendations for use.

Working point	Recommendations for use
Charging	The Battery System must be charged respecting the limits specified in the technical information.
	The system's maximum rated charging current is 140 A. The Master will reduce the current limit by regulation both in the final charge and in case of temperatures exceeding 45°C or temperatures lower than 20°C in the cell.
Discharging	The rated continuous discharge current of the system is 140 A. The maximum direct current is 200 A.
	The Master will gradually reduce this limit in the event of temperatures above 50°C or below 10°C in the cell.
	It must be taken into account that inverters in off-grid systems do not respect the discharge setpoint limits sent by the Master and operations may be affected if the final application is not correctly sized.

If these usage recommendations are not followed, the Master has event recording tools to ensure fulfilment of the warranty. See Annex A1 Warranty *document*.

To guarantee the cyclability of the Modules, deep discharges to the system (>80% DoD) are not recommended.

INFORMATION

If you require more technical information, please contact CEGASA.

7 SYSTEM SCALABILITY

This chapter describes the steps to follow to expand the Battery System both in number of strings in parallel and in number of Modules connected in series per string.

7.1 INCREASE NUMBER OF STRINGS

If users wish to increase the number of strings connected in parallel to increase the useful capacity of the storage system, the following checks must first be carried out:

- Ensure that the SoH of the old system is not less than 75%. A system interconnection with disparate SoH can cause an imbalance in the circulation of charge or discharge currents and therefore loss of capacity of the entire system since the SoH is related to the internal resistance of the Battery System.
- Ensure that the maximum number of parallels CEGASA recommends for its system is not exceeded. A high number of parallels can cause unwanted current circulation between parallels and therefore a reduced total useful capacity.
- Ensure there is sufficient space to allow the minimum distance between Modules as recommended by CEGASA.
- Bring the current installed system to a 100% SoC and then lower it to 70% (+/-2%) since the new Battery Systems received will be in said SoC. When installing Modules with different SoC, imbalances can be generated in the currents and in the system's SoC.
- Shut down the Battery System (see Chapter 6.2 "*System shutdown*").
- Shut down the inverters connected to the Battery System.

Once these checks have been completed, users can expand the system. Once the new parallel strings have been reconnected, users must reconfigure the system using the EViewer platform. To do this, follow the steps below:

1. Power all the BMUs by operating the lever and enabling the circuit breaker (CB) (up position) of each of them. Once the BMUs are powered, users will be able to connect to the EViewer platform using their selected browser on their device.
2. Enter with the installer username and corresponding password.
3. From the Configuration screen, open the "strings config" group and enter the total number of parallel groups (equivalent to the number of BMU control units).
4. Check that the Master unit is communicating correctly with all the BMU control units (that there are no alarms and it correctly reads variables from all the BMU control units in the battery tab).
5. The Master will recalculate the new SoH considering that the new parallels have a 100% SoH.

7.2 INCREASE NUMBER OF MODULES PER STRING

The number of Modules in series in the system is limited by the working voltage of the inverter. Some inverters have a reduced voltage working range and therefore the number of Modules in series may not be modified, but other inverters offer a wide working range, so the number of selected Modules can be modified.

NOTICE

Make sure you select a number of Modules in series appropriate for the working voltage range of the inverter and the maximum number of Modules in series specified for the HV EXpand line.

Before introducing a new Module into a Battery System in series you must take into account:

- The new Module introduced must have a 100% SoH but the final SoH of the string to which it is connected continues to have the previous value, marked by the life of the previous Modules of that string.
- The SoC of the new Module must be the same as the SoC of the series group in which the new Module is going to be introduced. Check with CEGASA to perform the procedure.
- The maximum number of Modules per tower must not be exceeded (nine in the case of the EXpand line).

Once the electrical connection has been made with the new Modules added, users must follow this procedure:

1. Power all the BMUs by operating the isolation switch lever and enabling the circuit breaker (CB) (up position). Users will then be able to connect to the EViewer platform using their selected browser on their device.
2. Enter with the installer username and corresponding password.
3. From the Configuration screen, open the "*strings config*" group and enter the total number of Modules per series (equivalent to the number of Modules controlled by each BMU).
4. Check that the Master unit is communicating correctly with all the BMUs (there are no alarms and all the variables of the connected BMUs appear correctly in the "*Batteries*" tab).

8 TROUBLESHOOTING

This chapter describes possible failures that may occur in the Battery System.

If due to any problem the system is in an alarm state, it issues the following notices.

- The LED on the start button emits a solid red light.
- The Master unit sends the alarm to the inverter via communications and it can therefore be viewed on the inverter's monitoring platform.
- It can be viewed on the EViewer web app (see Annex A4 *System configuration with the EViewer*)
- The event is recorded in the Master's log files.

NOTICE

If you are not able to start the system and check the error, please contact CEGASA after-sales.

Possible failures that may occur in the Battery System are described below.

Table 8-1. List of failures.

Code	Error	Description	Solution
324	Connection error in SCS	Problem in pre-charge or BMU contactors	Contact CEGASA after-sales service
-	SCS does not close contactor	One or more strings in parallel do not close the contactor	<ol style="list-style-type: none"> 1. Check that master has detected all parallels 2. Check that the voltage difference between parallels is less than 2V 3. Contact CEGASA after-sales service
313	Failure in BMS	BMS internal problem	Contact CEGASA after-sales service

Code	Error	Description	Solution
321	BMS communications error	SCS does not communicate with one or several BMS	<ol style="list-style-type: none"> 1. Check the correct wiring between the BMU and the Modules 2. Check correct configuration of number of Modules in the EViewer web app 3. Contact CEGASA after-sales service
441	SCS communications error	Master does not communicate with one or several BMUs	<ol style="list-style-type: none"> 1. Check the wiring between Master and BMU is correct 2. Restart all the BMUs 3. Contact CEGASA after-sales service
443	Inverter communication error	Master is not communicating with inverter.	<ol style="list-style-type: none"> 1. Check communications wiring between inverter and Battery System 2. Check pinout in Master is correct 3. Check that the inverter has been configured correctly in the EViewer web app 4. Contact CEGASA after-sales service
205	Module overdischarge	One or more Modules have been overdischarged	<ol style="list-style-type: none"> 1. Enable BMU circuit breaker (CB) (up position) 2. Charge the string as soon as possible

Code	Error	Description	Solution
-	Button LED off	The BMU is not on or the LED has failed.	<ol style="list-style-type: none"> 1. Check the circuit breaker (CB) is enabled (in up position) 2. Check the input voltage of the BMU (rear part) is correct. Use a multimeter 3. Contact CEGASA after-sales service
-	Current sensor failure	The Battery System does not measure current.	<ol style="list-style-type: none"> 1. Check current using a current clamp 2. Check contactor closure is correct by measuring the voltage at the BMU output (rear part). Use a multimeter 3. Contact CEGASA after-sales service
-	EViewer web app does not load	When entering the appropriate IP address in the browser, the EViewer web app does not load	<ol style="list-style-type: none"> 1. If the connection is via ETH cable, check that the IP is configured correctly on the PC 2. If the connection is via Wi-Fi and PC, check that the antivirus software does not block the connection. Try with ETH cable
-	Error during update	After the update process, the system is still in the previous version	<ol style="list-style-type: none"> 1. Switch the whole system off and on again and repeat the process 2. Contact CEGASA after-sales service

9 SYSTEM DISASSEMBLY

CAUTION!

The Battery System must be disassembled by qualified personnel.

CAUTION!

Risk of injury due to the weight of the Modules.

Injuries can occur if Modules are lifted incorrectly or dropped during transportation or installation.

- Transport and lift the Modules carefully. Take their weight into account.
 - Wear appropriate personal protective equipment for all work on the Battery System.
-

To disassemble the system, please follow the procedure below:

1. Turn off all inverters connected to the system.
2. Turn off all circuit breakers and/or protection elements between the inverter and the Battery System in the PDC cabinet.
3. Take the side covers off the rack.
4. Turn off each of the circuit breakers (CB) located on the BMU.

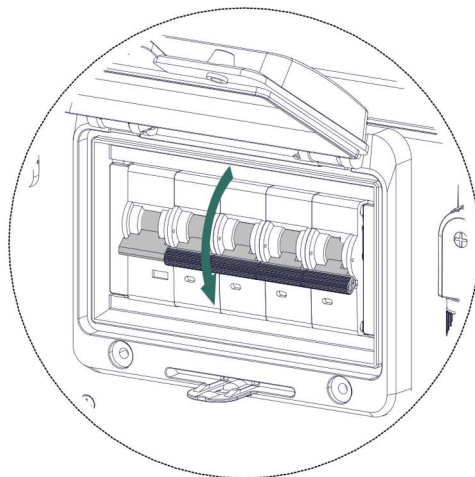

Figure 9-1. Disconnect the circuit breakers (CB).

5. Place the front isolation switch lever in the **OFF** position .

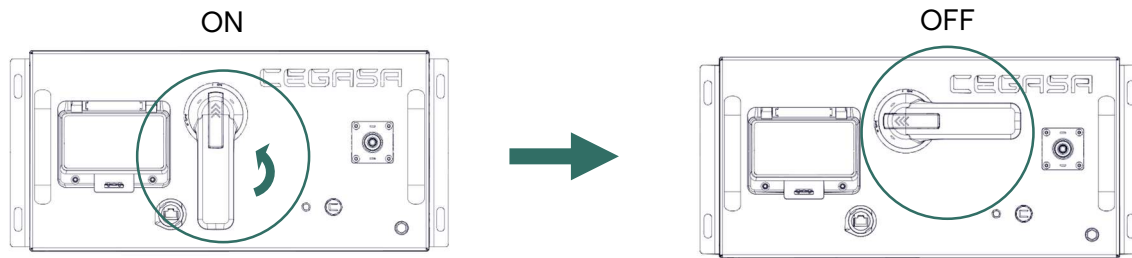

Figure 9-2. Lever in OFF position.

6. Disconnect the communications cable between the inverter and the EXpand Master MCS.
7. Disconnect the power cable from the EXpand Master MCS.
8. Loosen the screws securing the Master to the wall and remove.
9. In the case of a system with several BMUs, disconnect the communication cables between them.
10. Disconnect the positive and negative cables of each BMU.
11. Disconnect the power cables from each string.
12. Disconnect the communications cables from each string.
13. Disconnect the earthing cables from each string.
14. Loosen the screws securing the modules and BMU to the frame.
15. Using the necessary lifting methods, remove all the Modules and BMUs from the rack.
16. Loosen and remove the screws connecting the racks (if two racks are installed).
17. Loosen the screws of the brackets securing the frame to the wall and remove these brackets.
18. Loosen the screws securing the frames to the floor.
19. Remove the frame.
20. If the Battery System is to be stored or shipped, package the system. Use the original packaging or suitable packaging for the weight and dimensions of the system.
21. Dispose of or recycle the Battery System according to locally applicable disposal regulations.

10 DISPOSAL SYSTEM

- The Battery System can only be disposed of in accordance with current local regulations on used batteries. If the Battery System is damaged, contact the manufacturer to receive appropriate instructions.
- You must contact the installer or distributor before disposing of it.



ENVIRONMENTAL

Do not dispose of the Battery System with household waste under any circumstances.

- Ensure that the Battery System is not exposed to moisture or direct sunlight once uninstalled.
- Used Battery Systems may contain harmful substances that can harm the environment or health if not stored or disposed of properly.
- Battery Systems contain important raw materials such as iron, zinc, manganese, copper, cobalt and nickel, which can be recycled.

11 TRANSPORT AND STORAGE REQUIREMENTS AND RECOMMENDATIONS

Battery Systems contain hazardous substances categorised as class 9 by the ADR 2013 document identified by number UN3481.

11.1 SHIPMENT

- Ship the Modules in packaging group 1, with approved boxes. Recommendation: do not discard the original shipping boxes.
- Transport with ADR authorisation to move Battery Systems.
- Smoking is prohibited in the vehicle during journeys and also in the vicinity during loading and unloading.
- It is prohibited for the carrier or any unqualified third party not associated with the installation to open the outer packaging of the Battery System.

11.2 ENVIRONMENTAL REQUIREMENTS FOR USE

The area where the system is installed must be equipped with an air conditioning system in order to carry out the system charging and discharging process within the recommended operating temperature.

- Operating temperature range for charging: **0°C to 45°C**
- Operating temperature range for discharging: **-20°C to 55°C**
- Recommended operating temperature range: **15°C to 25°C**
- Operating humidity range (HR): **15% to 90%**

The Battery System control has an internal algorithm to modulate the charge and discharge current depending on the SoC and the temperature of the cells.



INFORMATION

Working outside the recommended temperature range may cause the Battery System to enter alarm or temperature protection state (over or under). It can also lead to a reduction in the life of the system, also affecting the terms of the system warranty (see Annex A1 Warranty document”).

11.2.1 Storage recommendations:

- Do not expose the Battery System to precipitation or direct sunlight.
- Do not expose to saline and/or highly corrosive environments.
- Recommended storage SoC (30%-70%).
- Recommended storage temperature (15°C to 25°C).
- Recommended storage humidity range (HR): 15% to 90%.
- Do not exceed 6 months of storage without performing a charge/discharge cycle (*).

11.2.2 Deviations:

- Do not store the Battery System below -5°C.
- Do not store the Battery System above 50°C.
- The Battery System can be stored for 6 months between 0°C and 25°C.
- The Battery System can be stored for 3 months between -10°C and 35°C.
- The Battery System can be stored for 1 month between -20°C and 45°C.

(*) Recommended Module charging cycle: Ask CEGASA.



INFORMATION

If the above instructions for storing the Battery System are not followed, the lifecycle will be reduced drastically (see Annex A1 Warranty *document*”).

12 MAINTENANCE PLAN

12.1 MAINTENANCE PLAN

The Battery System requires low maintenance. However, a system maintenance procedure must be performed to ensure optimal operation.

This procedure provides the guidelines to follow to ensure proper maintenance, maximising performance and prolonging the lifetime of the Battery System. Follow these instructions to keep the system in optimal condition. Not following these instructions may lead to the reduced life of the system, also affecting the terms of the system warranty (see Chapter 1.8 "*Limitation of warranties and liability*").

12.1.1 Training and Safety

Ensure that the personnel responsible for maintaining the Battery System are adequately trained in maintenance and safety procedures. Use suitable personal protective equipment when handling Battery Systems and follow all relevant safety regulations.

12.1.2 Cleaning

It is recommended to periodically clean all the equipment comprising the energy storage Battery System. If the casing is dirty, use a soft dry cloth or a vacuum cleaner to remove dust. Do not use liquids such as solvents, abrasive products or corrosive liquids.

12.1.3 Storage

A system charge/discharge cycle must be carried out depending on the storage conditions (temperature and storage time), see Chapter 11 "*Transport and storage requirements and recommendations*".

12.1.4 Temperature

In storage, keep the Modules in an environment with an appropriate and stable temperature. Install in a well-ventilated place protected from direct exposure to sunlight and severe weather conditions.

When in use, ensure that all equipment is working within the temperature range specified by CEGASA (see Chapter 11.2 "*Environmental requirements for use*"). Otherwise, have the necessary resources available (isolation, air conditioning, etc.).

12.1.5 Regular Visual Inspection

Carry out periodic visual inspections to detect any physical damage to the system. Pay special attention to the terminals and connections.

12.1.6 Voltage control

Regularly check that the Battery System voltage is within the limits specified by CEGASA on the EViewer platform, see Annex A4 *System configuration with the EViewer web app*.

12.1.7 Full charge

Fully charge the battery system at least once a month to update possible deviations from the SoC calculation algorithm, see Annex A1 *Warranty document*".

12.1.8 Deep discharges

Avoid discharging the Battery System below an SoC of 10%. Deeper discharges will significantly affect the lifetime. If the Battery System is overdischarged, its protection will be triggered, but it is important to ensure the following:

- Charge the overdischarged Battery System within 7 days if the room temperature is equal to or greater than 25°C.
- Charge the overdischarged Battery System within 15 days if the room temperature is below 25°C, see Annex A1 *Warranty document*".

12.1.9 Checking notices and alarms

Regularly check that there are no notices and/or alarms. CEGASA app, see Chapter 8 "*Troubleshooting*".

12.1.10 Log and documentation

Keep a detailed log of all maintenance activities performed on the energy storage Battery System, including inspection dates, voltage measurements, cleaning and any other actions taken. Keep these logs up-to-date to make it easier to track the system status.

12.1.11 Updating firmware

Make sure your system is updated with the latest FW version.



INFORMATION

Please contact CEGASA if you require more technical information.



INFORMATION

This maintenance plan must be followed to make the product warranty effective.

12.2 CORRECTIVE MAINTENANCE PLAN

In the event of a breakdown and you need to replace any unit of the Battery System, please contact CEGASA's technical team (SAT) for assistance. Under no circumstances should you manipulate or open any unit; if you do, the warranty will be fully void.

13 TECHNICAL DATA SHEET (TDS)

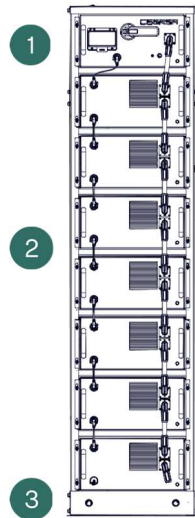

- 1 BMU control module
- 2 HV EXpand Modules
- 3 Frame

MODULES	7	8	9	10	11	12
Energy (kWh)	100	114	129	143	157	172
Usable energy (kWh, 90% DoD)	90	103	116	129	141	155
Rated voltage (V)	358	410	461	512	563	613
Voltage range (V)	325–386	371–442	418–497	464–552	510–607	557–662
Recommended current (A)	140					
Maximum current (A)**	200					
Peak current (A) (<1 min)**	350					
Rated power (kW)	72	82	93	103	113	123
Dimensions (mm)	524x824x2152	1085x842x1642	1085x842x1642	1085x842x1642	1085x842x1642	1085x842x2152
Weight (kg)	970	1150	1270	1390	1510	1650
Cycles (0.2, 25°C)	>6000					
Operational temp (°C)	From -5 to 45					
Protection rating	IP30					
Efficiency (0.2, 25°C)	>96%					
Communications	CAN bus, MODBUS TCP/IP (Sunspec)					
Certifications	CE / IEC62619 / IEC62620 / EN61000-6-2 / EN61000-6-3 / UN38.3					

MODULES	13	14	15	16	17	18
Energy (kWh)	186	200	215	229	243	257
Usable energy (kWh, 90% DoD)	167	180	194	206	219	231
Rated voltage (V)	666	717	768	819	870	922
Voltage range (V)	603–718	650–773	696–828	742–883	789–938	835–993
Recommended current (A)	140					
Maximum current (A)**	200					
Peak current (A) (<1 min)**	350					
Rated power (kW)	134	144	154	165	175	185
Dimensions (mm)	1085x842x2152	1085x842x2152	1084x842x2152	1625x842x1642	1625x842x1642	1625x842x2152
Weight (kg)	1770	1920	2050	2190	2310	2460
Recommended temp (°C)	>6000					
Operational temp (°C)	From -5 to 45					
Protection rating	IP30					
Efficiency (0.5, 25°C)	>96%					
Communications	CAN bus, MODBUS TCP/IP (Sunspec)					
Certifications	CE / IEC62619 / IEC62620 / EN61000-6-2 / EN61000-6-3 / UN38.3					

Derating may be applicable due to temperature and voltage

UP TO 10 STRINGS IN PARALLEL

The HV EXpand line offers the possibility of paralleling up to 10 strings in a final system.

Contact CEGASA with regard to other configurations

14 SPECIFIC INVERTER ANNEXES

A1 WARRANTY DOCUMENT

A2 CAN BUS COMMUNICATIONS PROTOCOL

A3 MOD BUS COMMUNICATIONS PROTOCOL

A4 SYSTEM CONFIGURATION WITH THE EVIEWER WEB APP

A5 IP CONFIGURATION OF PC DEVICES

Energy you can trust

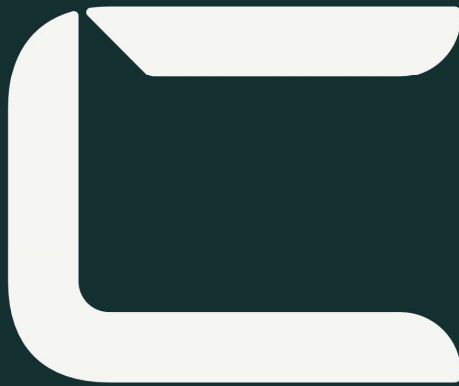

CEGASA

Spain. Production Centre
Cegasa Energía S.L.U.
Parque Tecnológico de Álava, Calle Marie Curie 1
01510 Miñano, Vitoria-Gasteiz (Álava, Spain)

www.cegasa.com
hello@cegasa.com

+34 945 31 37 38